

**2024**

**CITY OF PHOENIX  
SUPPLEMENTAL  
STANDARD DETAILS  
FOR  
PUBLIC WORKS  
CONSTRUCTION**



**2024 CITY OF PHOENIX SUPPLEMENTAL STANDARD DETAILS TO THE 2024 MAG  
UNIFORM STANDARD, SPECIFICATIONS AND DETAILS FOR PUBLIC WORKS CONSTRUCTION**

The **2024 edition** of the City of Phoenix Supplements to the 2024 Maricopa Association of Governments Uniform Standard Specifications and Details for Public Works Construction is effective January 2025. The 2024 edition supersedes all previous editions.

All public works construction contracts advertised and all permits issued on or after January 1, 2025 shall be governed by the **2024 edition**.

A copy of the **2024 edition** is available for review and download on the City of Phoenix Website at the following address:

<https://www.phoenix.gov/Streets/MAGSupplements>

For more information, or a copy of this publication in an alternate format, contact Street Transportation Department at 602-262-6284 (Voice) and 7-1-1 (FRIENDLY) (TTY).

This Page Reserved for Future Use

## New Supplemental Standard Details

<b>Detail Number</b>	<b>Title</b>
P1315	Water Meter Box Cover
P1320	Non Traffic Rated Water Meter Boxes
P1440-1	Sewer Service Connection Lateral Seal

## Updated Supplemental Standard Details

<b>Detail Number</b>	<b>Title</b>
P1121	8" & 10" V.C.P Trench Loading
P1122	12" & 15" V.C.P Trench Loading
P1123	18" & 21" V.C.P Trench Loading
P1124	24" & 27" V.C.P. Trench Loading
P1125	30" & 33" V.C.P. Trench Loading
P1126	36" & 39" V.C.P. Trench Loading
P1127	42" V.C.P. Trench Loading
P1360	Fire Hydrant Assembly

**Deleted Supplemental Standard Details:**

<b><u>Detail Number</u></b>	<b><u>Title</u></b>
P1315	Steel Water Meter Box Cover

## **MAG Standard Details Not Approved for Use in City of Phoenix:**

<b>Detail Number</b>	<b>Title</b>
MAG 302	JOINT RESTRAINT WITH TIE RODS
MAG 321	STANDARD WATER METER VAULT
MAG 340	INSTALLING TAPPING SLEEVES AND VALVES
MAG 360-2	WET BARREL FIRE HYDRANT INSTALLATION
MAG 360-3	FIRE HYDRANT INSTALLATION DETAILS
MAG 380	THRUST BLOCKS FOR WATER LINES
MAG 381	ANCHOR BLOCKS FOR VERTICAL BENDS
MAG 389	CURB STOP WITH VALVE BOX AND COVER
MAG 390	CURB STOP WITH FLUSHING PIPE
MAG 391-1	VALVE BOX INSTALLATION AND GRADE ADJUSTMENT
MAG 391-2	VALVE BOX INSTALLATION AND GRADE ADJUSTMENT
MAG 392	DEBRIS CAP INSTALLATION
MAG 425	24" ALUMINUM MANHOLE FRAME AND COVER
MAG 441	SEWER CLEANOUT
MAG 530	3-6" CURB OPENING CATCH BASIN TYPE 'A'

1000 SERIES  
TRAFFIC ENGINEERING

NO	TITLE	DATE
P1010	MINIMUM ARTERIAL STREET CROSS SECTIONS	2008
P1013	MINIMUM COLLECTOR STREET CROSS SECTIONS	2008
P1014	MINIMUM LOCAL STREET CROSS SECTIONS	2008
P1017	ACCESS ROAD OPENING	1992
P1018	ACCESS ROAD TERMINATION AT ALLEYS	2000
P1019	ACCESS ROAD TERMINATION AT INTERSECTION	2008
P1020-1	PLANNED AREA DEVELOPMENT	2015
P1020-2	PRIVATE ACCESS WAY	2008
P1021	PRIVATE DRIVEWAY (STREET) (FOR PLANNED AREAS, SUB-LOTS, SPECIAL PERMITS, ETC)	1992
P1024	STEEL PIPE BARRICADE	1992

1100 SERIES  
GENERAL INFORMATION

NO	TITLE	DATE
P1106	BARRICADE	1992
P1120	V.C.P. TRENCH LOADING	2021
P1121	8" & 10" V.C.P. TRENCH LOADING	UPDATED 2024
P1122	12" & 15" V.C.P. TRENCH LOADING	UPDATED 2024
P1123	18" & 21" V.C.P. TRENCH LOADING	UPDATED 2024
P1124	24" & 27" V.C.P. TRENCH LOADING	UPDATED 2024
P1125	30" & 33" V.C.P. TRENCH LOADING	UPDATED 2024
P1126	36" & 39" V.C.P. TRENCH LOADING	UPDATED 2024
P1127	42" V.C.P. TRENCH LOADING	UPDATED 2024
P1130	MULTI-USE TRAILS AND SHARED-USE PATHS	2021
P1131	VERTICAL CLEARANCE, MULTI-USE, SHARED-USE, AND UNDERPASS/BRIDGE CLEARANCE	2021
P1164	MAXIMUM DRIVEWAYS & ALLEYS SLOPE	2021
P1165	DEBRIS CAP INSTALLATION	2021
P1170	TRENCHING STEEL PLATE	1992
P1173	SAFETY RAILING DETAIL	2021
P1174	CONDITIONS WHERE SAFETY RAILS ARE REQUIRED	2012
P1180	GENERAL NOTES	2021
P1181	SINGLE REFUSE BIN ENCLOSURE	2021
P1182	DOUBLE REFUSE BIN ENCLOSURE	2021
P1183	TRIPLE REFUSE BIN ENCLOSURE	2021
P1184	RESTAURANT ENCLOSURE WITH GREASE TRAP	2021
P1185	RECYCLE ADDITION, REAR-LOAD, AND LIMITED ACCESS BIN ENCLOSURES	2021
P1186	LARGE COMPACTOR BIN ENCLOSURE	2021
P1187	COLLECTION PADS FOR SMALL/MULTI LOT WITH PRIVATE DRIVES	2021
P1188	COLLECTION PADS FOR SMALL/MULTI LOT WITH PRIVATE DRIVES NOTES	2021
P1189	REFUSE BIN ENCLOSURE SCREEN WALL AND SAFETY BOLLARD DETAILS	2021

1200 SERIES  
STREET INFORMATION

NO	TITLE	DATE
P1200	TRENCH BACKFILL & SURFACE REPLACEMENT	2015
P1230	SIDEWALKS	2015
P1231	APRON JOINTS	2015
P1232	TRUNCATED DOMES DETAIL	2021
P1233	CURB RAMP DETAIL WITH LANDSCAPE PLANTERS	2021

1200 SERIES  
STREET INFORMATION (CONTINUED)

NO	TITLE	DATE
P1236	CURB RAMP DETAIL WITH NO LANDSCAPE PLANTERS	2021
P1237	CURB RAMP DETAIL- ALL RADIUS CURB RETURNS, LIMITED RIGHT OF WAY	2021
P1239	CURB RAMP DETAIL, 20' RADIUS RETURNS, 4" VERTICAL CURB RETURN	2021
P1240	SINGLE CURB RAMP DETAIL ALL RADIUS CURB RETURNS	2021
P1240-1	SINGLE CURB RAMP DETAIL WITH LIMITED R/W	2021
P1240-2	CURB RAMP DETAIL WITH ATTACHED S/W (CORNER AT A DIAGONAL)	2021
P1240-3	CURB RAMP DETAIL WITH DETACHED S/W (CORNER AT A DIAGONAL)	2021
P1241-1	CURB RAMP DETAIL (MID BLOCK)	2021
P1241-2	CURB RAMP DETAIL (MID BLOCK) WITH DETACHED SIDEWALK	2021
P1241-3	CURB RAMP DETAIL(MID BLOCK) WITH 4" ROLL CURB	2021
P1241-4	CURB RAMP DETAIL (MID BLOCK) MODIFIED (LIMITED RIGHT OF WAY)	2021
P1243	RETURN TYPE DRIVEWAYS WITH ATTACHED SIDEWALK	2004
P1243-1	LIMITED ACCESS DRIVEWAY WITH NO LT-IN AND WITHOUT DECELERATION LANE	2015
P1243-2	LIMITED ACCESS DRIVEWAY WITH NO LT-IN/OUT AND WITHOUT DECELERATION LANE	2015
P1243-3	LIMITED ACCESS DRIVEWAY WITH NO LT-IN AND WITH DECELERATION LANE	2015
P1243-4	LIMITED ACCESS DRIVEWAY WITH NO LT-IN/OUT AND WITH DECELERATION LANE	2015
P1243-5	LIMITED ACCESS DRIVEWAY WITH NO LT-OUT AND WITHOUT DECELERATION LANE	2021
P1244	DRIVEWAY-PEDESTRIAN RAMP COMBINATION (FOR USE AT T TYPE INTERSECTIONS)	2008
P1255-1	DRIVEWAY ENTRANCE - TYPE I (SIDEWALK ADJACENT TO CURB)	2008
P1255-2	DRIVEWAY ENTRANCE- TYPE II (DETACHED SIDEWALK)	2008
P1255-3	DRIVEWAY ENTRANCE- ADA RETROFIT	2003
P1255-4	DRIVEWAY WIDTHS POLICY	2008
P1255-5	DRIVEWAY ENTRANCE	2021
P1256-1	BUS BAY (TYPE 1)	2008
P1256-2	BUS BAY (TYPE 2)	2008
P1258	BUS SHELTER PAD LOCATION (BUS STOP)	2008
P1260	BUS SHELTER/ACCESSORY PAD BUS STOP	2021
P1261	BUS SHELTER/ACCESSORY PAD BUS BAY	2021
P1262	PARKWAY BUS SHELTER/ACCESSORY PAD	2021
P1263-1	BUS SHELTER/ACCESSORY PAD FRONTAGE ROAD MID-BLOCK	2008
P1263-2	PARKWAY BUS SHELTER/ACCESSORY PAD	2008
P1270	FRAME AND COVER INSTALLATION AND GRADE ADJUSTMENT	2008
P1270-1	SECURE VALVE BOX LID TYPE A	2001





1300 SERIES  
WATER INFORMATION

NO	TITLE	DATE
P1315	STEEL WATER METER BOX COVER	DELETED 2024
P1315	WATER METER BOX COVER	NEW 2024
P1320	NON TRAFFIC RATED WATER METER BOXES	NEW 2024
P1342	WATER SERVICE CONNECTIONS	2021
P1343	WATERLINE - CUT AND PLUG FOR 12" DIA. MAIN AND SMALLER	1994
P1344	WATERLINE CUT OUT (TEES & CROSSES) FOR 12" DIA. MAIN AND SMALLER	1992
P1351	REDUCED PRESSURE PRINCIPLE BACKFLOW PREVENTION ASSEMBLY INSTALLATION - 3" AND OVER	2001
P1352	DOUBLE CHECK VALVE BACKFLOW PREVENTION ASSEMBLY INSTALLATION - 3" AND OVER	2001
P1353	DOUBLE CHECK VALVE BACKFLOW PREVENTION ASSEMBLY INSTALLATION - 2 1/2" AND UNDER	2001
P1354	REDUCED PRINCIPLE BACKFLOW PREVENTION ASSEMBLY INSTALLATION - 2 1/2" AND UNDER	2001
P1355	PRESSURE VACUUM BREAKER ASSEMBLY INSTALLATION 2" AND UNDER	2001
P1356	TEMPORARY SUPPORT FOR FIRE HYDRANT BACKFLOW ASSEMBLY	2001
P1359	HYDRANT GUARDS	2001
P1360	FIRE HYDRANT ASSEMBLY	UPDATED 2024
P1361	FIRE HYDRANT THREADS 2 1/2" & 4"	1992
P1362	FIRE HYDRANT LOCATION	2004
P1363	WATER METER LOCATION	2000
P1370	VERTICAL REALIGNMENT OF WATERLINE	2012
P1391	VALVE BOX INSTALLATION	2008
P1391-1	VALVE OPERATING NUT EXTENSION	2001
P1394	PRESSURE REDUCING & SUSTAINING VALVE	1992
P1395	WATER LINE SUSPENSION	1992
P1396	DOUBLE CHECK VALVE ASSEMBLY	1992

1400 SERIES  
SANITARY SEWER INFORMATION

NO	TITLE	DATE
P1424	24" & 30" MANHOLE COVERS	2012
P1424-1	STORM DRAIN MANHOLE COVER	2015
P1435	SANITARY SEWER MANHOLE KNOCKOUT	2004
P1440	SEWER BUILDING CONNECTION & ELECTRONIC MARKERS	2012
P1440-1	SEWER SERVICE CONNECTION LATERAL SEAL	NEW 2024

1500 SERIES  
IRRIGATION & STORM INFORMATION

NO	TITLE	DATE
P1520	STORM DRAIN MANHOLE BASE 48" & SMALLER	1992
P1560	STORM DRAIN MANHOLE BASE TRANSITION 51" & LARGER	2015
P1561	FRAME AND COVER CATCH BASIN ACCESS	2008
P1562	BARRIER SPECIFICATION SCHEDULE	2003
P1563	STORM DRAIN OUTFALL ACCESS BARRIER	2015
P1564	CATCH BASIN GRATE FRAMES	1992
P1565	CATCH BASIN GRATES	2015
P1566	CATCH BASIN COMBINATION TYPE "J" WITH CONCRETE APRON	2012
P1567	CATCH BASIN COMBINATION TYPE "K"	2012
P1568	CATCH BASIN - TYPE "L" CURB & PARKWAY OPENING INLET DETAILS	2012
P1569-1	CATCH BASIN TYPE "M"	2012
P1569-2	CATCH BASIN - TYPE "M" TOP MODIFICATION IN LANDSCAPE PARKWAY	2012
P1570	CATCH BASIN TYPE "N"	2012
P1571	CATCH BASIN - TYPE "P" DOUBLE CURB OPENING FOR FRONTAGE ROAD ISLANDS	2012
P1572	CATCH BASIN TYPE "Q"	2012
P1573	CATCH BASIN TYPE "R"	2012
P1574	INLET CURB OPENING & PIPE ENTRY DETAIL	1992
P1576	CAST-IN-PLACE PIPE LATERAL PIPE CONNECTION	1999
P1577	SMALL STORM DRAIN LATERAL OR CATCH BASIN CONNECTOR PIPE CONNECTION TO EXISTING STORM DRAIN MAIN	2015
P1578	LARGE STORM DRAIN LATERAL OR CATCH BASIN CONNECTOR PIPE TO EXISTING RCP STORM DRAIN MAIN	2015
P1581	CATCH BASIN - TYPE "M" MODIFIED (OFFSET OPENING)	2000
P1583	CATCH BASIN - TYPE "L-R" MODIFIED (WITH REAR INLET)	2012
P1584	CATCH BASIN - TYPE "R" MODIFIED (WITH WING AND OFFSET OPENING)	2012

GREEN INFRASTRUCTURE/LOW IMPACT DEVELOPMENT DETAILS

NO	TITLE	DATE
LID-01	PERMEABLE PAVEMENT	2021
LID-02	CURB OPENINGS	2021
LID-03	CURB OPENINGS	2021
LID-04	SEDIMENT TRAPS	2021
LID-05	STORMWATER HARVESTING BASINS	2021
LID-06	VEGETATED OR ROCK BIOSWALES	2021
LID-07	BIORETENTION SYSTEMS	2021
LID-10	DOMED OVERFLOW STRUCTURES	2021



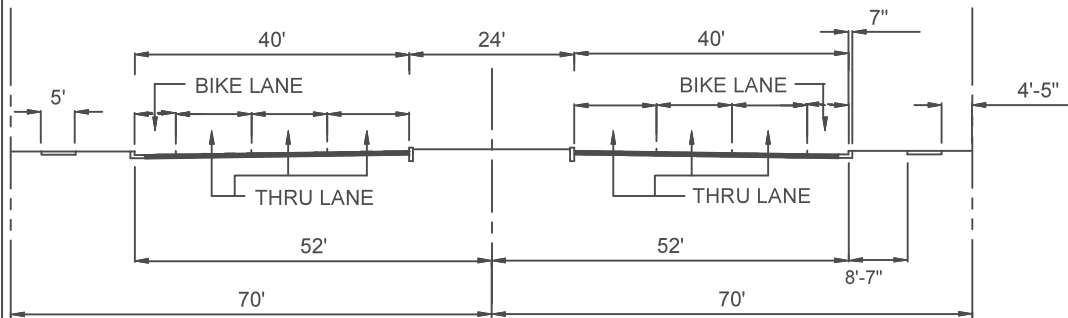

CROSS SECTION A

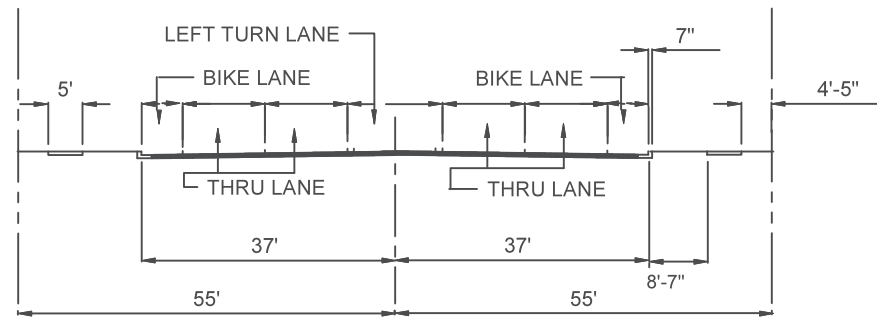

CROSS SECTION C  
CROSS SECTION C-M. (SEE NOTE 4)

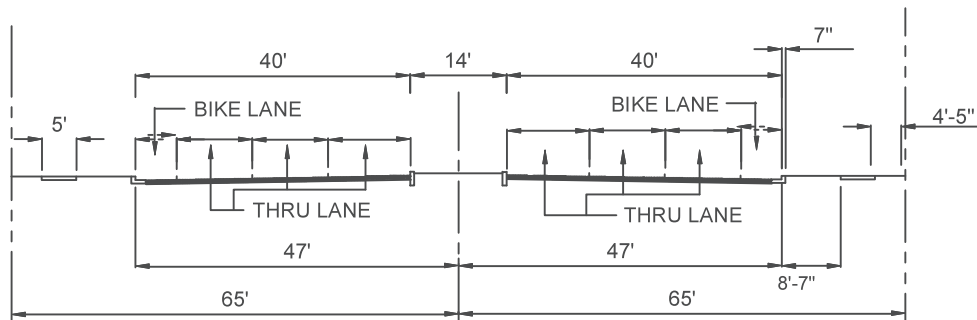

CROSS SECTION B

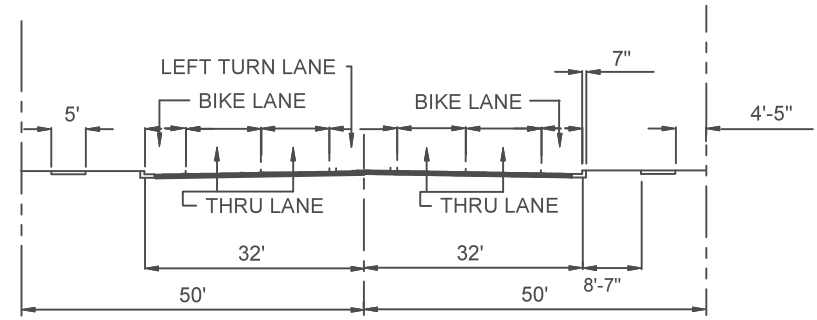

CROSS SECTION D

**NOTES:**

1. LANE WIDTHS AND CONFIGURATION ARE CONCEPTUAL ONLY. FINAL LANE WIDTHS AND CONFIGURATION TO BE APPROVED BY THE STREET TRANSPORTATION DEPT.
  2. ADDITIONAL RIGHT-OF-WAY MAY BE REQUIRED FOR DRAINAGE, UTILITIES, SLOPE RIGHTS, TRAFFIC SIGNALS, IRRIGATION FACILITIES OR TRAILS.\*\*
  3. CROSS SECTION "C" HAS A 14' TWO WAY LEFT TURN LANE.  
CROSS SECTION "C-M" HAS A 14' RAISED MEDIAN.
  4. ALL DIMENSIONS ARE TO THE FACE OF CURB.
- \*\* ACCORDING TO THE TRAILS PLAN, A 10 FOOT SIDEWALK MAY BE REQUIRED ON CROSS SECTIONS A, B, C, D, E, F, & G.

DETAIL NO.  
P1010



**City of Phoenix**  
**STANDARD DETAIL**

MINIMUM ARTERIAL STREET  
CROSS SECTIONS

APPROVED

*[Signature]*  
ACTING CITY ENGINEER

7/31/08  
DATE

DETAIL NO.  
P1010

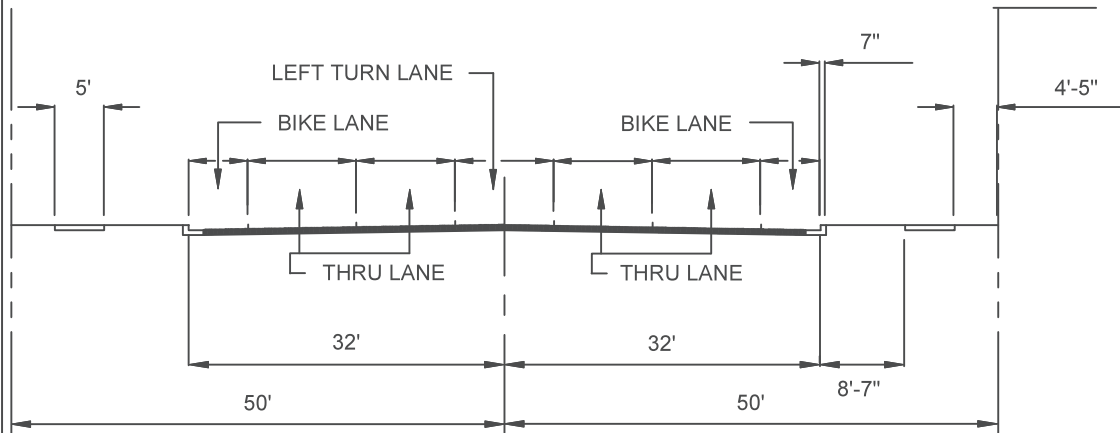

CROSS SECTION D

NOTES:

- 1. LANE WIDTHS AND CONFIGURATION ARE CONCEPTUAL ONLY. FINAL LANE WIDTHS AND CONFIGURATION TO BE APPROVED BY THE STREET TRANSPORTATION DEPT.
- 2. ADDITIONAL RIGHT-OF-WAY MAY BE REQUIRED FOR DRAINAGE, UTILITIES, SLOPE RIGHTS, TRAFFIC SIGNALS, IRRIGATION FACILITIES OR TRAILS.
- 3. ALL DIMENSIONS ARE TO THE FACE OF CURB.

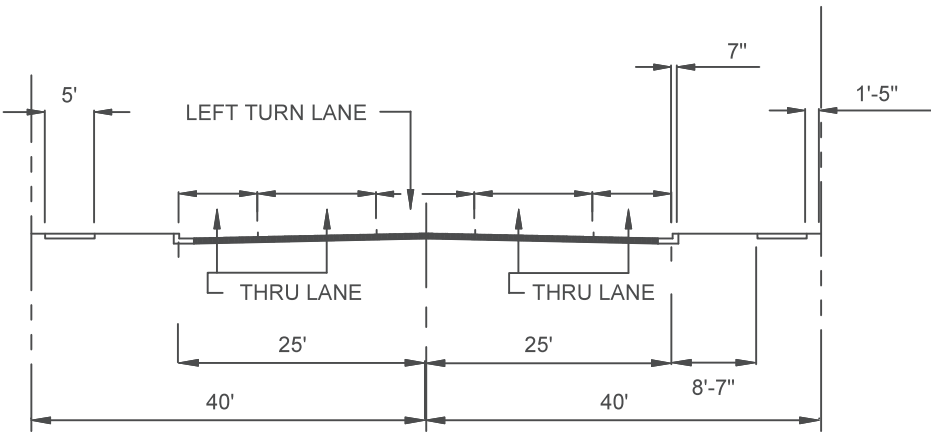

CROSS SECTION E

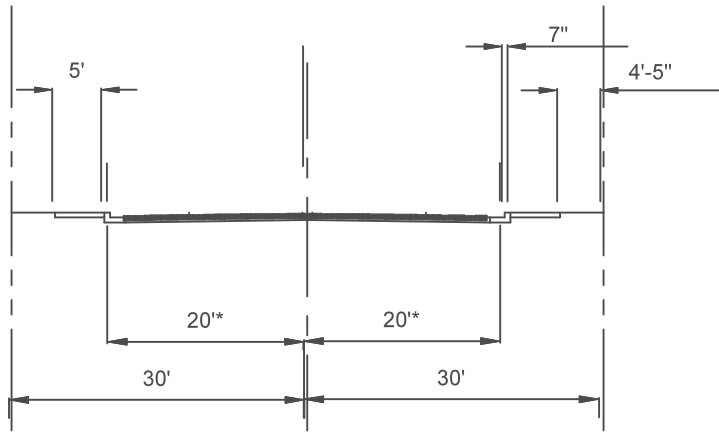

CROSS SECTION F

\* COLLECTORS WITH RESIDENTIAL BACKUP TREATMENT MAY BE 18'.

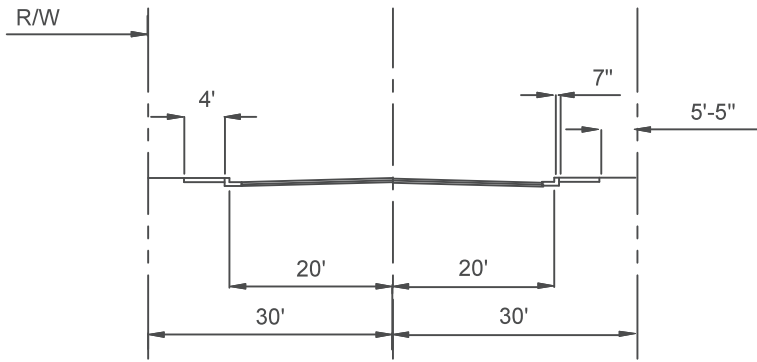

**CROSS SECTION F**

INDUSTRIAL LAND USE  
VERTICAL CURB AND ADJACENT SIDEWALK

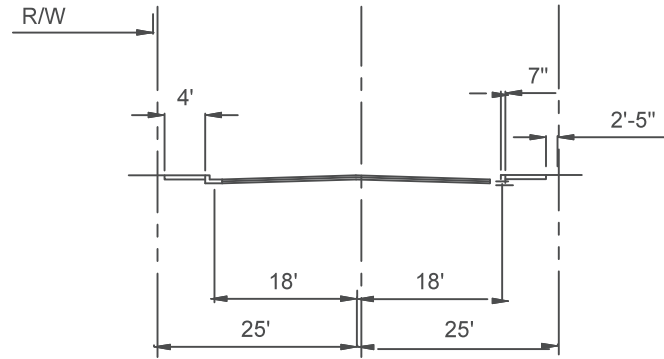

**CROSS SECTION G**

COMMERCIAL & MULTI FAMILY  
RESIDENTIAL LAND USE  
VERTICAL CURB AND ADJACENT SIDEWALK

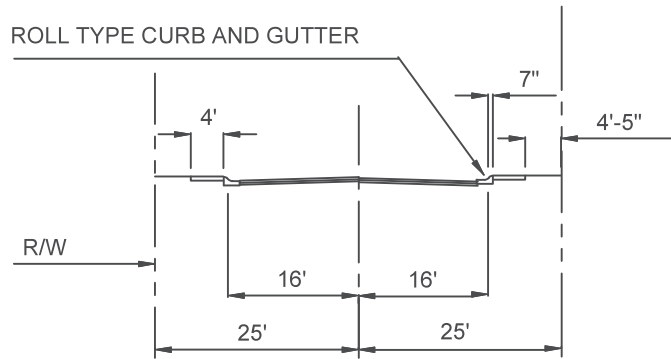

**CROSS SECTION H**

SINGLE FAMILY RESIDENTIAL LAND USE

OPTION A:  
ROLL CURB AND ADJACENT SIDEWALK

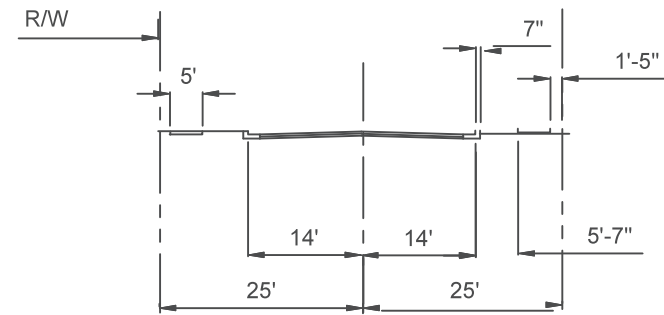

**CROSS SECTION I**

SINGLE FAMILY RESIDENTIAL LAND USE

OPTION B:  
VERTICAL CURB AND SET BACK SIDEWALK

**NOTES:**

LANE WIDTHS AND CONFIGURATION  
ARE CONCEPTUAL ONLY. FINAL  
LANE WIDTHS AND CONFIGURATION  
TO BE APPROVED BY THE STREET  
TRANSPORTATION DEPT.

ADDITIONAL RIGHT-OF-WAY  
MAY BE REQUIRED FOR DRAINAGE,  
UTILITIES, SLOPE RIGHTS,  
IRRIGATION FACILITIES, OR TRAILS.

ALL DIMENSIONS ARE TO THE  
FACE OF CURB.

ALL CURBS ARE VERTICAL  
UNLESS NOTED.



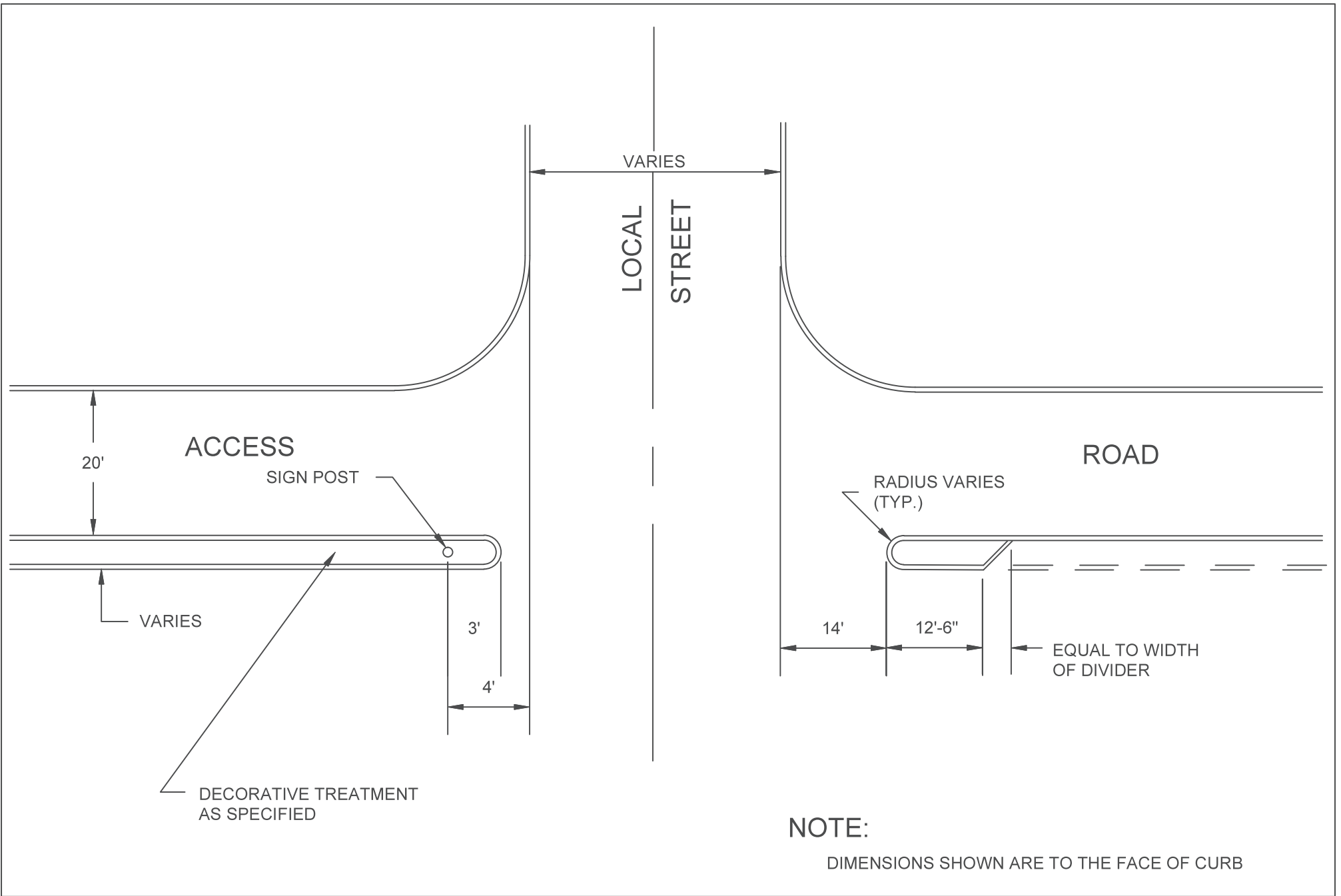

**NOTE:**  
DIMENSIONS SHOWN ARE TO THE FACE OF CURB

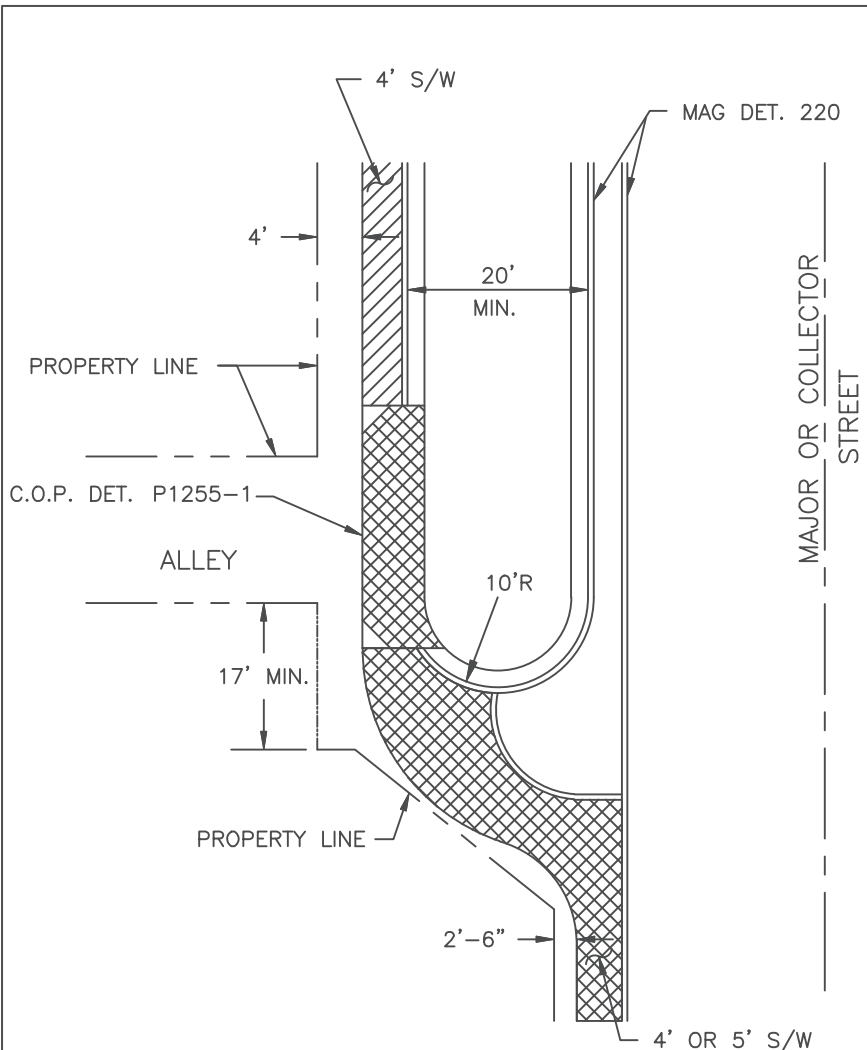

NOTE:  
SUFFICIENT RIGHT-OF-WAY MUST BE AVAILABLE TO  
CONSTRUCT ACCESS ROAD TERMINATION

SINGLE FAMILY ALLEY

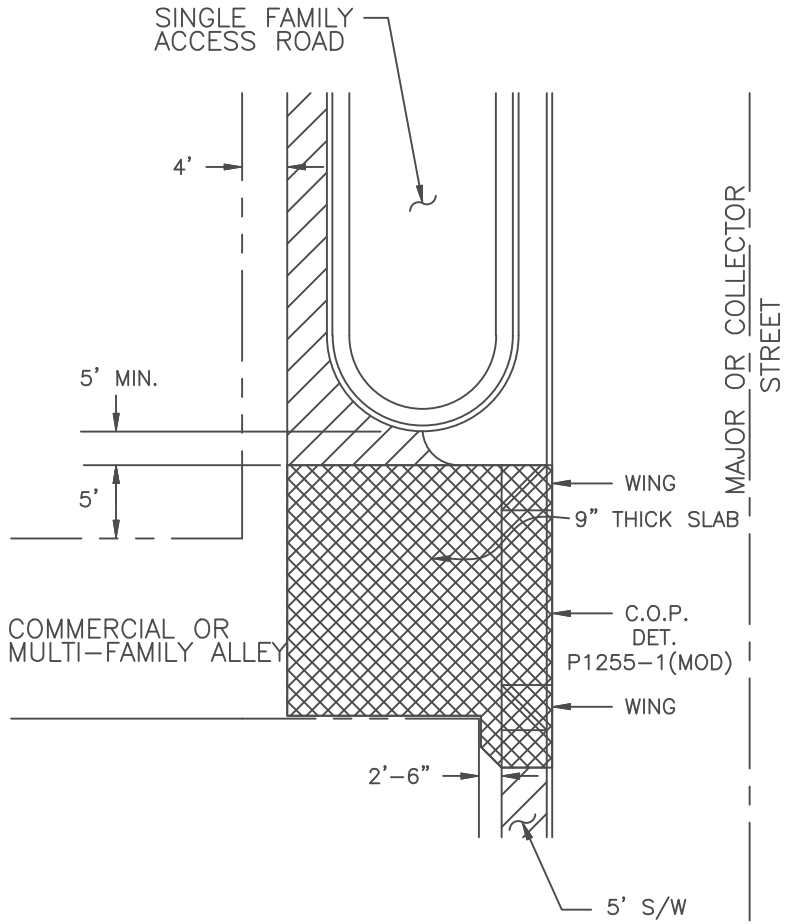

NOTE:  
1. COMMERCIAL AND MULTI-FAMILY ALLEYS MAY NOT PROVIDE  
ACCESS TO SINGLE FAMILY ACCESS ROADS.  
2. ONLY ALLOWED FOR LOCATIONS WHERE REFUSE  
COLLECTION IS NOT PROVIDED ALONG THE ACCESS ROAD.

COMMERCIAL OR MULTI-FAMILY ALLEY

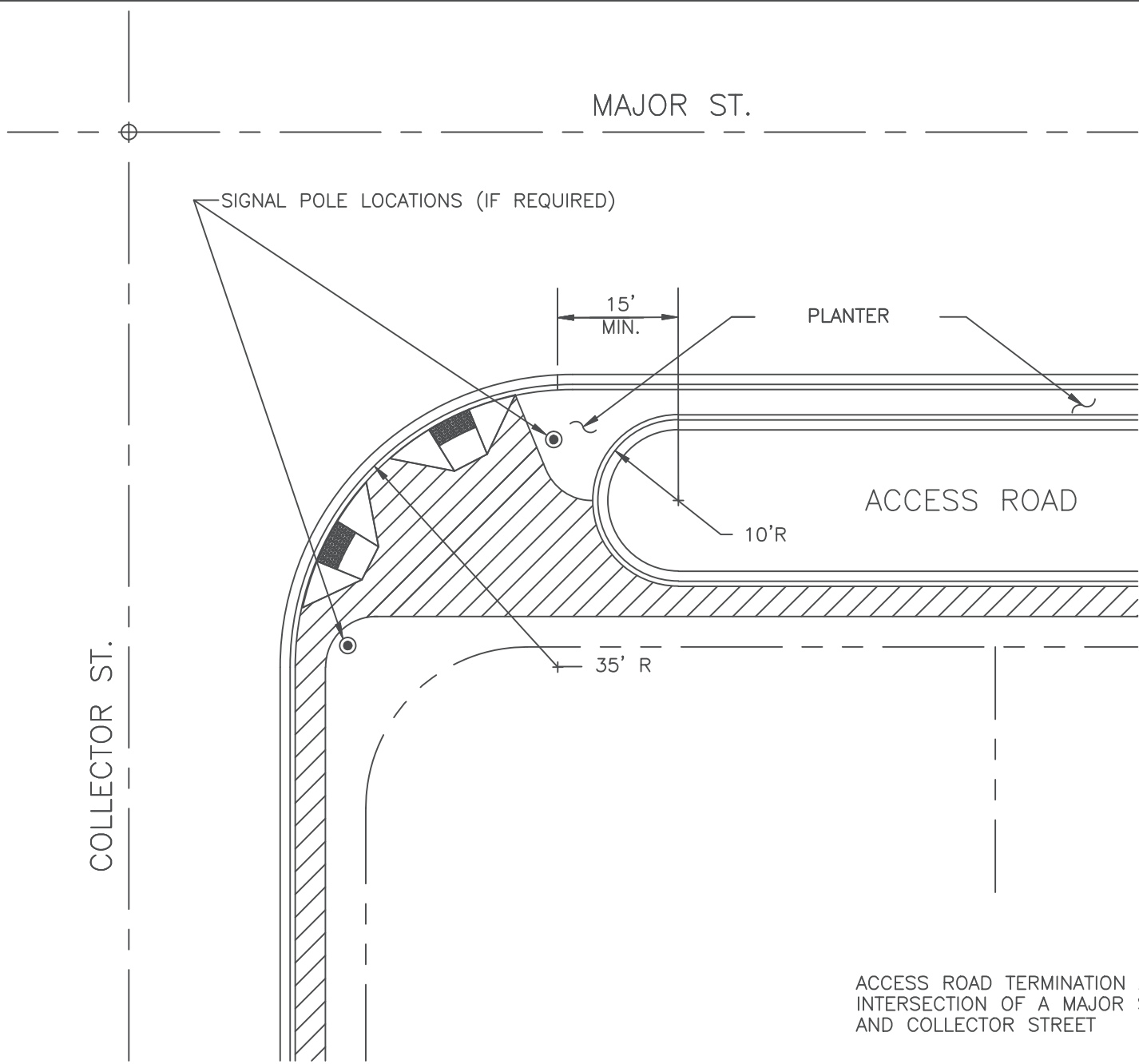

ACCESS ROAD TERMINATION AT THE INTERSECTION OF A MAJOR STREET AND COLLECTOR STREET

REVISED 4/14/08

A PRIVATE ACCESSWAY IS INTENDED TO APPLY TO PRIVATE STREETS WITHIN DEVELOPMENTS SUCH AS PRD'S PAD'S, MOBILE-HOME PARKS, AND HILL SIDE DEVELOPMENTS WHERE LOT SALES ARE PROPOSED.

1. PRIVATE ACCESS WAYS WILL BE ALLOWED IN NEW DEVELOPMENTS WHERE THEIR USE IS LOGICALLY CONSISTENT WITH A DESIRE FOR NEIGHBORHOOD IDENTIFICATION AND CONTROL OF ACCESS, AND WHERE SPECIAL OVERALL DESIGN CONCEPTS MAY BE INVOLVED.
2. PRIVATE ACCESS WAYS WILL BE PERMITTED ONLY WHERE A SATISFACTORY MEANS OF PROVIDING FOR THEIR MAINTENANCE AND OPERATION IS DEMONSTRATED.
3. THE USE OF PRIVATE ACCESS WAYS AS A DEVICE FOR PERMITTING INADEQUATE DESIGN WILL NOT BE ALLOWED.
4. THE USE OF PRIVATE ACCESS WAYS IS ORDINARILY LIMITED TO CUL-DE-SACS AND TO LOCAL STREETS NOT CARRYING THROUGH TRAFFIC. NORMALLY COLLECTOR STREETS WILL BE PUBLIC. FURTHER, THERE WILL BE AN ADEQUATE INTERNAL CIRCULATION SYSTEM AND NO PROPERTY WILL BE LANDLOCKED BY A PRIVATE ROAD SYSTEM.
5. THE DESIGN OF ALL PRIVATE ACCESS WAYS SHALL BE REVIEWED AND APPROVED BY D.S.D. THE CONSTRUCTION SHALL BE INSPECTED BY D.S.D., WITH A STANDARD INSPECTION FEE TO BE PAID.
6. NOTE TO BE PLACED ON PLAT "PRIVATE ACCESS WAY, NOT DEDICATED FOR PUBLIC USE".
7. THE HOMEOWNER'S ASSOCIATION CONSTITUTION AND BY-LAWS SHALL INCLUDE ACKNOWLEDGEMENT OF THE OWNERSHIP AND MAINTENANCE RESPONSIBILITY OF THESE PRIVATE FACILITIES, INCLUDING RESPONSIBILITY FOR ENFORCEMENT OF TRAFFIC CONTROL.
8. GATED ENTRIES ARE ALLOWED IF TURNAROUND AREAS ARE PROVIDED PER DSD GATED ENTRY DETAILS

I GENERAL

1. PRIVATE ACCESS WAYS, AND/OR REFUSE COLLECTION EASEMENTS MAY BE USED IN PAD'S, MOBILE-HOME DEVELOPMENTS AND PRD'S AND SHALL BE KNOWN AS "PRIVATE ACCESS WAYS". UTILITIES MAY BE PLACED IN A PRIVATE ACCESS WAY IF THEY ARE AT LEAST 28' WIDE.
2. MAJOR DRAINAGE WAYS SHALL BE DEDICATED.
3. SIDEWALKS ARE NORMALLY REQUIRED ADJACENT TO ALL COLLECTOR STREETS AND IN ALL MULTIFAMILY DEVELOPMENTS AND DEVELOPMENTS WITH LOTS LESS THAN 18,000 SQ. FT. OR IN THE SAID EASEMENT RIGHT OF WAY UNLESS OTHER MEANS OF ACCOMMODATING PEDESTRIAN TRAFFIC ARE PROVIDED IN THE DEVELOPMENT.
4. PRIVATE ACCESS WAYS SHALL BE ADEQUATELY DESIGNED TO CITY SPECIFICATIONS TO PROVIDE FOR LANE DELINEATION, STREET SWEEPING, AND DRAINAGE CONTROL. NORMALLY, A CROWN SECTION WITH CONCRETE CURB OR CONCRETE CURB AND GUTTER ON BOTH SIDES WILL BE REQUIRED; HOWEVER, OTHER MEANS OF PROVIDING SIMILAR FUNCTIONAL CHARACTERISTICS MAY BE CONSIDERED IF APPROVED BY THE PLAN REVIEW TEAM.
5. RETURN-TYPE DRIVEWAY ENTRANCE MAY BE USED ON PRIVATE ACCESS WAYS. IF THE STREET IS 28' OR GREATER. DEPRESSED DRIVEWAY APPROACHES SHALL BE USED WHERE THERE IS ONLY DIRECT ACCESS TO A PARKING AREA OR WHERE THE STREET IS LESS THAN 28' WIDE.

II MINIMUM PAVEMENT WIDTHS

THE ENTIRE WIDTH OF THE PRIVATE ACCESS WAY SHALL BE DESIGNATED BY PLAT AS A "PRIVATE ACCESS WAY".

<u>STREET CLASSIFICATION</u>	<u>CURB TO CURB</u>	<u>CURB RETURNS</u>
COLLECTOR	36'-40'	35'
LOCAL STREETS		
WITH PARKING PLANNED ON BOTH SIDES	29'-36'	20'
WITHOUT PLANNED PARKING	24'	25'
ONE-WAY, PLANNED PARKING ONE SIDE	22'-24'	25'

III GRADES

1. DESIRABLE MAXIMUM - 10%
2. MAXIMUM - 15%
3. MINIMUM - 0.30% - GRADES LESS THAN 0.30% SHALL REQUIRE CONCRETE VALLEY GUTTERS, ABSOLUTE MINIMUM GRADE 0.15%.

IV ALIGNMENT

1. STREET SHALL NORMALLY INTERSECT AT RIGHT ANGLES AND NO GREATER DEFLECTION THAN 15° FROM A RIGHT ANGLE WILL BE ALLOWED AND SHALL HAVE AT LEAST 20' TANGENT ADJACENT TO INTERSECTIONS. THE TANGENT LENGTH SHALL BE INCREASED WHERE SHORT RADIUS CURVES ARE USED NEAR THE INTERSECTIONS.
2. CUL-DE-SACS SHALL NOT ORDINARILY EXCEED 400' IN LENGTH. CURB RADIUS TO FACE OF CURB AT THE TURNAROUND SHALL BE 45' RADIUS MINIMUM.
3. IN SPECIAL SITUATIONS WHERE CITY REFUSE COLLECTION AND/OR CITY MAINTENANCE IS NOT REQUIRED, DEAD-ENDED PRIVATE ACCESS WAYS MAY BE USED AND SHOULD NOT EXCEED 300 LINEAL FEET. ADEQUATE TURNAROUND FACILITIES MAY BE REQUIRED AT THE END OF EACH DEAD-ENDED PRIVATE ACCESS WAY FOR EMERGENCY VEHICLE TURNAROUND.
4. CENTERLINE RADIUS SHALL BE 100' MINIMUM FOR LOOP STREETS AND LOCAL STREETS OVER 800' IN LENGTH. WHERE RIGHT-ANGLED BENDS ARE USED IN THE STREET PATTERN IN LIEU OF THE MINIMUM RADII REQUIRED ABOVE, WIDENING SUFFICIENT TO ACCOMMODATE TRUCK-TURNING MOVEMENTS SHALL BE PROVIDED BY USE OF KNUCKLES OR OTHER APPROPRIATE MEANS.

V STRUCTURAL SECTION

THE MINIMUM STRUCTURAL DESIGN OF PAVING, CURB, GUTTER, AND SIDEWALK SHALL BE IN ACCORDANCE WITH CITY STANDARDS AND SPECIFICATIONS.

VI UTILITIES

1. ADEQUATE PROVISIONS FOR PUBLIC UTILITIES SHALL BE MADE.
2. FIRE HYDRANTS SHALL BE LOCATED ON THE PUBLIC STREET AT THE ENTRANCE TO THE PRIVATE ACCESS WAYS AND ALONG PRIVATE ACCESS WAYS AS REQUIRED BY THE CITY OF PHOENIX WATER AND WATER SERVICES DEPARTMENT STANDARDS.
3. STANDARDS OF CONSTRUCTION AND INSPECTIONS ON PRIVATE ACCESS WAYS SHALL BE TO CITY OF PHOENIX STANDARDS AND SPECIFICATIONS.
4. COSTS OF MAINTENANCE AND REPAIRS OF PRIVATE ACCESS WAYS, LIGHTS, AND NON-PUBLICLY-OWNED UTILITIES ARE TO BE THE RESPONSIBILITY OF THE HOMEOWNER'S ASSOCIATION.
5. PUBLIC WATER AND SEWER LINES ARE ACCEPTABLE WITHIN 28' WIDE OR GREATER PRIVATE ACCESSWAYS WITH AN EXCLUSIVE EASEMENT FOR PUBLIC WATER & OR SEWER.
6. SOME TYPE OF PRIVATE STREET LIGHTS ARE TO BE PROVIDED.

VII SIGNS

1. ALL NEW CURB SHALL BE IMPRINTED WITH THE WORDS, "PRIVATE STREET - NO CITY MAINTENANCE" IN 2" HIGH LETTERS AT EVERY CURB RETURN AND AT EVERY ENTRANCE INTO A NEW PRIVATE PROPERTY SUBDIVISION.
2. A STOP SIGN SHALL BE POSTED AT ALL INTERSECTIONS OF PRIVATE ACCESS WAYS WITH PUBLIC STREETS. SIGNS SHALL BE IN ACCORDANCE WITH THE MANUAL OF UNIFORM TRAFFIC CONTROL DEVICES AND SHALL BE MAINTAINED BY THE HOMEOWNER'S ASSOCIATION.



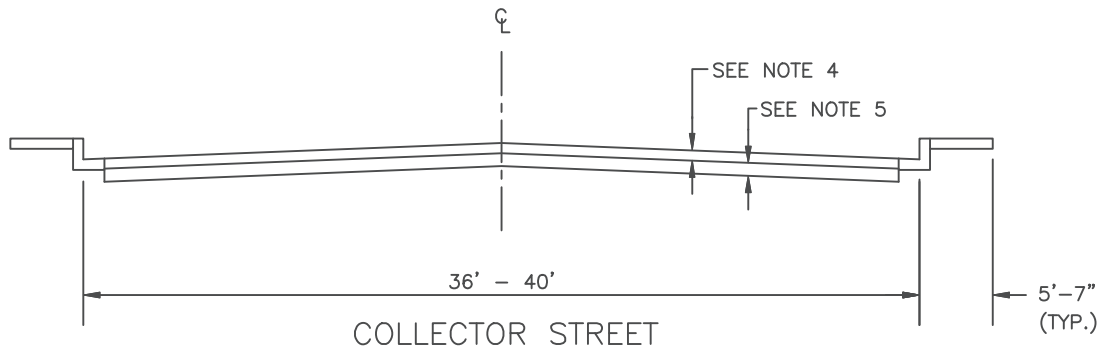

NOT TO SCALE

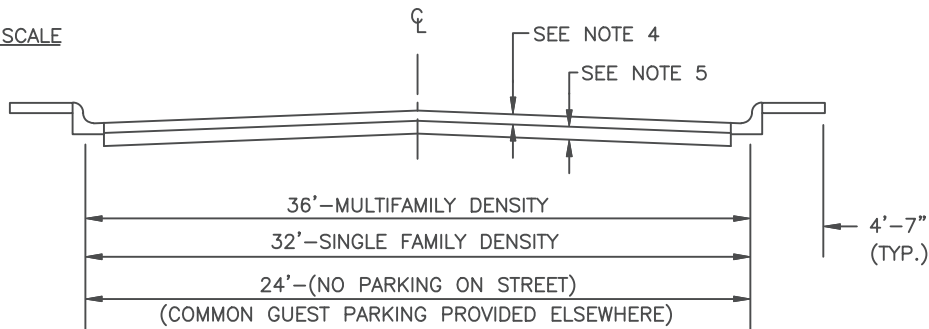

NOT TO SCALE

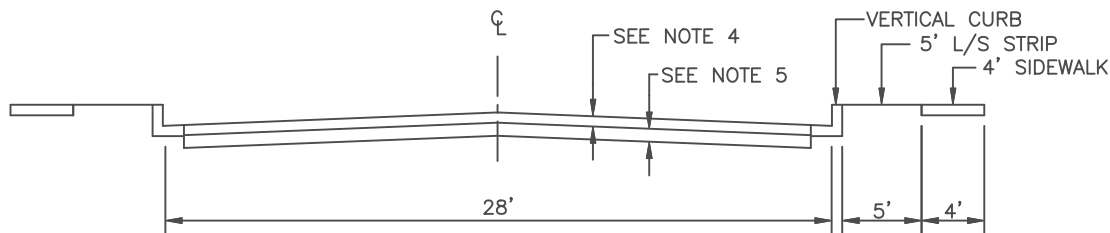

NOT TO SCALE

NOTES:

1. DRIVEWAY ENTRANCE RETURNS - VERTICAL CURB FACE
  - A. COLLECTOR STREET - 35' RADIUS TO FACE OF CURB
  - B. LOCAL STREET (36' OR 32' WIDE) - 20' RADIUS TO FACE OF CURB
  - C. LOCAL STREET (24' OR 28' WIDE) - 25' RADIUS TO FACE OF CURB
2. SIDEWALK-STD. DET. P1230. THE SITE DEVELOPMENT MANAGER MAY WAIVE THE REQUIREMENT FOR SIDEWALKS, IF SIDEWALKS PROVIDED ELSEWHERE IN THE DEVELOPMENT WILL SATISFACTORILY SERVE THE SAME PURPOSE.
3. CURBS
  - A. COLLECTOR STREET & MULTIFAMILY DENSITY - STD. DET. 220-1 TYPE "A" (VERTICAL CURB AND GUTTER)
  - B. LOCAL STREET-STD. DET. 220-1 TYPE "C" (ROLL CURB AND GUTTER) OR STD. DET. 221 WHEN SIDEWALK IS ADJACENT, RIBBON CURBS WILL BE PERMITTED WHERE DRAINAGE WILL BE RETAINED OR ADEQUATE DRAINAGE CHANNELS ARE PROVIDED THROUGH ADJACENT PROPERTY. RIBBON CURB MAY NOT BE USED ADJACENT TO SIDEWALK.
4. ASPHALT CONCRETE-2" THICKNESS, CONFORM TO M.A.G. SECT. 321. OTHER TYPES OF SURFACE TREATMENT MAY BE PERMITTED BY AUTHORITY OF THE PAVING PLAN REVIEW SUPERVISOR AFTER DEMONSTRATION THAT STRUCTURAL STRENGTH IS EQUAL TO OR GREATER THAN THAT OF THE EXISTING CITY STANDARDS.
5. AGGREGATE BASE COURSE-THICKNESS TO CONFORM WITH P1103. INSTALL TO CONFORM WITH M.A.G. SECT. 310.
6. STREET FURNITURE, FIRE HYDRANTS AND MAJOR PLANTINGS SHALL BE SET BACK A MINIMUM OF 5' FROM THE BACK OF CURB AND BUILDINGS SHALL BE SET BACK A MINIMUM OF 10' FROM THE BACK OF CURB.
7. GARAGES ARE TO BE SETBACK 18' FROM BACK OF SIDEWALK.

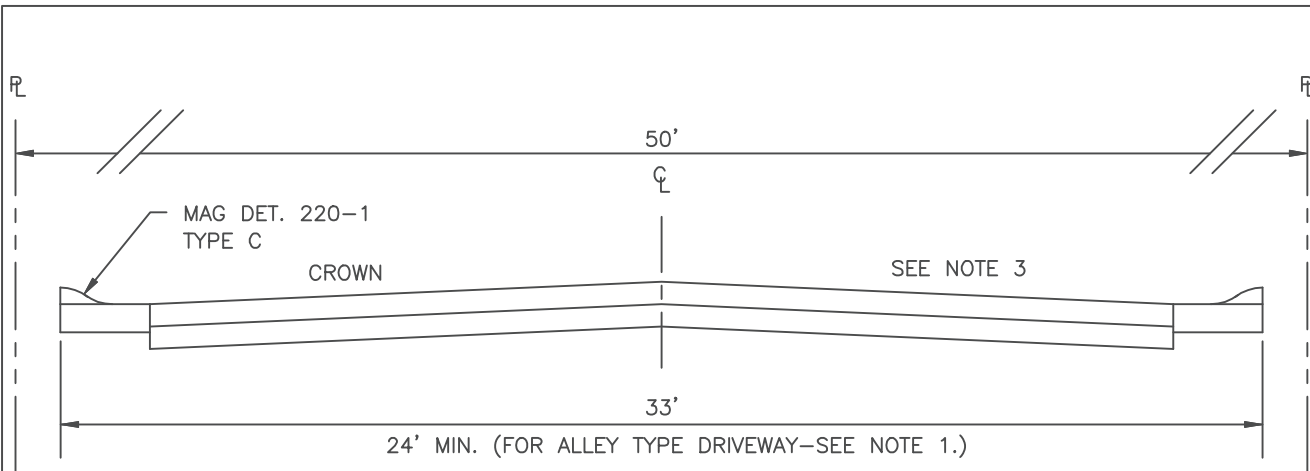

NORMAL CROWN

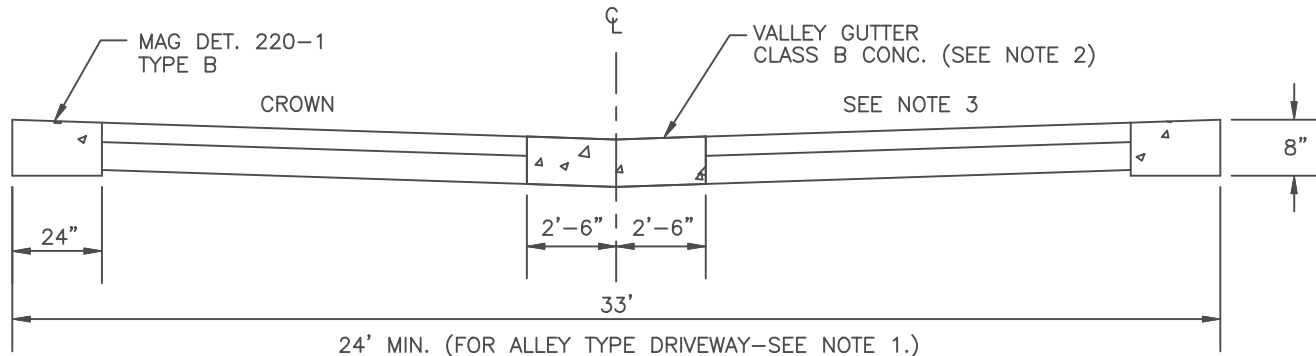

INVERTED CROWN

NOTES:

1. 24' MIN. WIDTH MAY BE APPROVED FOR SHORT DEAD-END OR CUL-DE-SAC DRIVEWAYS OR DRIVEWAYS IN APARTMENT TYPE DEVELOPMENT. A 3' UTILITY EASEMENT TO BE DEDICATED ADJACENT.
2. GRADES
  - (A) MAX.-15%. STREET GRADES EXCEEDING 12% SHOULD HAVE MAX. LENGTH OF 600'.
  - (B) DESIRABLE MIN. GRADE-0.25%.
  - (C) WHEN THE LONGITUDINAL GRADE OF INVERTED CROWN IS LESS THAN 0.30%, CONC. VALLEY GUTTER SHALL BE INSTALLED.
3. CROWN
  - (A) 5" TO 6" WHERE STREET GRADE IS LESS THAN 0.25%.
  - (B) 4" TO 5" WHERE STREET GRADE EXCEEDS 0.25%.
  - (C) INVERTED CROWN 4" TO 6", NOTE: FOR 24' WIDTH DRIVEWAYS DEDUCT 1" FROM ABOVE CROWNS.
4. WITH INVERTED CROWN STREETS, ROLL CURB, WITH DEPRESSED LIP, MAY BE SUBSTITUTED FOR RIBBON TYPE CURB.
5. RIBBON TYPE CURB IS NOT TO BE INSTALLED IF S/W ARE PROPOSED.
6. CONCRETE PER MAG SEC. 725 & 505.

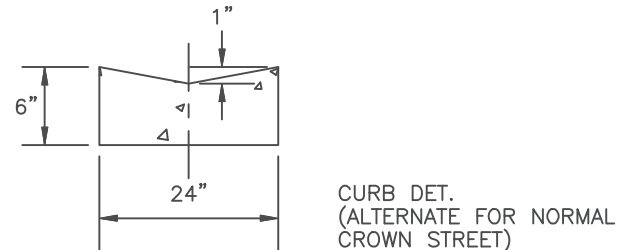
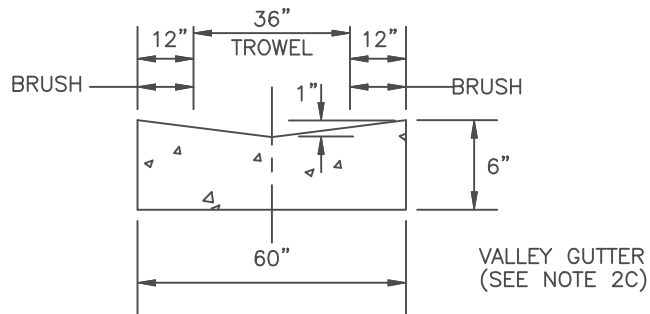

DETAIL NO.  
P1021



PRIVATE DRIVEWAY (STREET) (FOR  
PLANNED AREAS, SUB-LOTS, SPECIAL PERMITS, ETC.)

APPROVED

*Kenny Whelan*  
CITY ENGINEER

7/9/92  
DATE

DETAIL NO.  
P1021

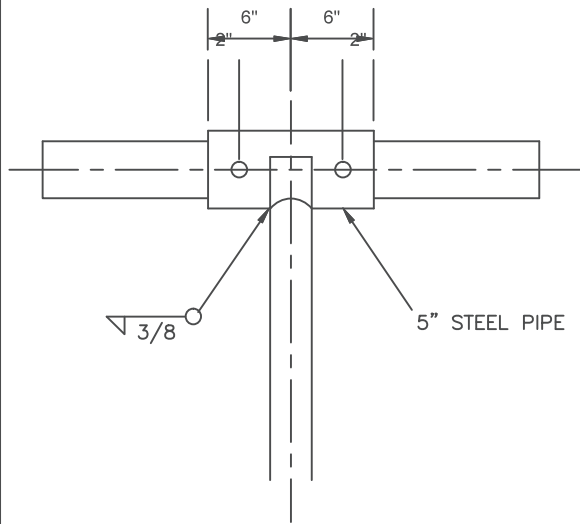

"T" SLEEVE OPTION

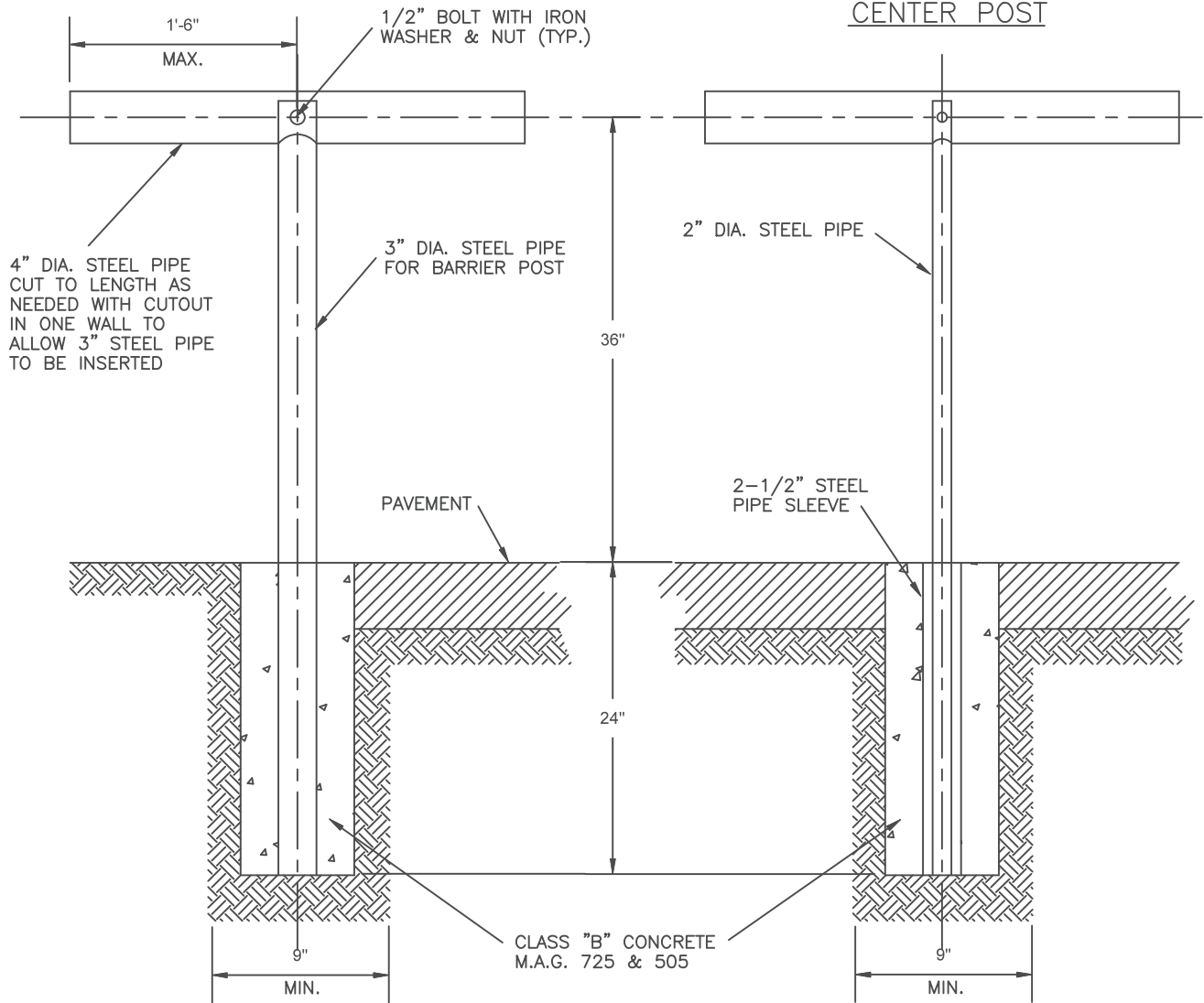

NOTES:

1. 1'-6" MAX. OVERHANG
2. MAX. OVERALL LENGTH IS 33'
3. CENTER POST REQUIRED IF CLEAR SPAN EXCEEDS 15'.
4. CENTER POST SHALL BE 2" DIA. WITH A 2-1/2" DIA. SLEEVE IN THE FOOTING.
5. ALL PIPE IS SCHEDULE 40, GALVANIZED STEEL. (ASTM A 53)

DETAIL NO.  
P1024



**City of Phoenix**  
**STANDARD DETAIL**

STEEL PIPE BARRICADE

APPROVED

*Kenny Whelan*  
CITY ENGINEER

7/9/92  
DATE

DETAIL NO.  
P1024

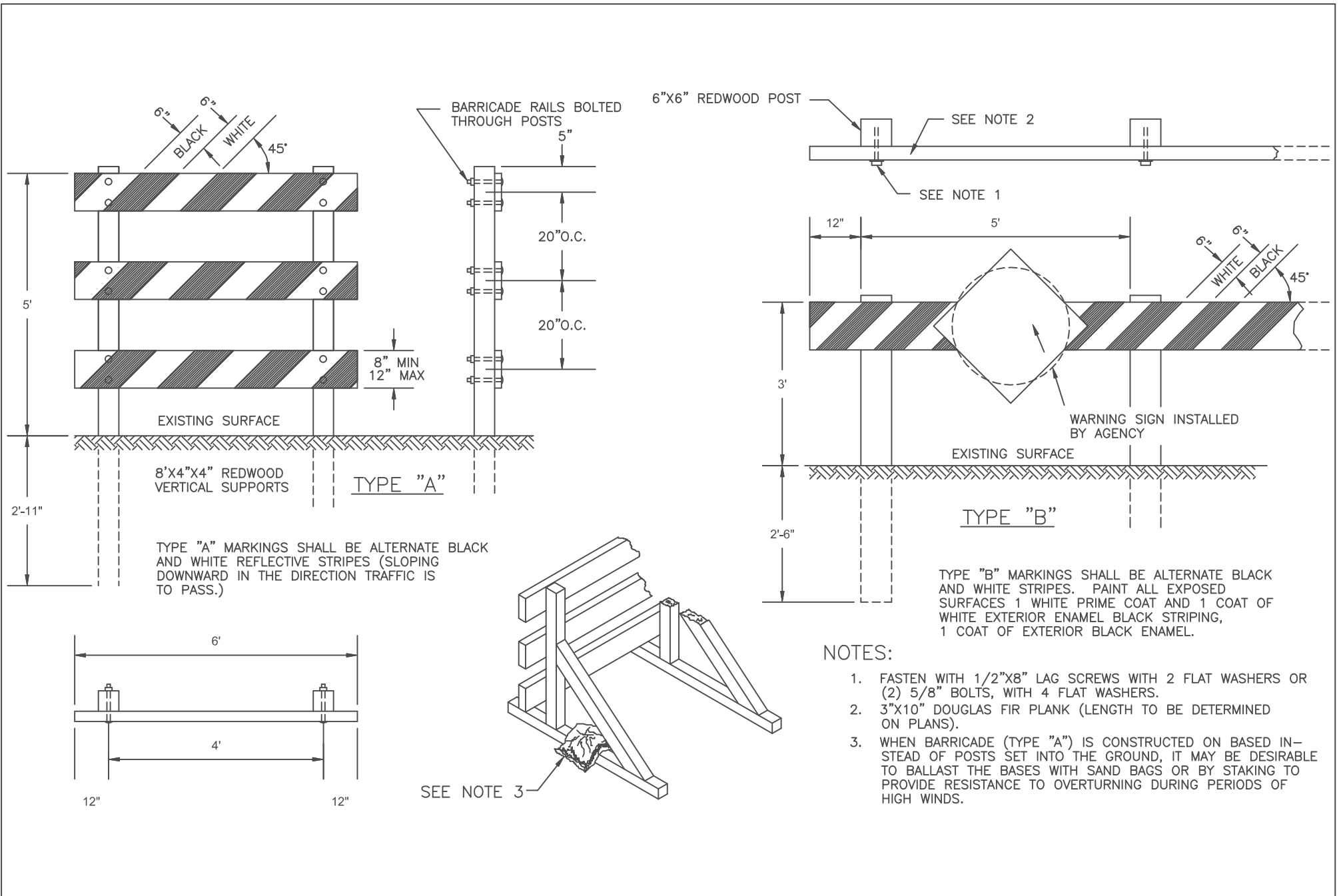

- NOTES:
1. FASTEN WITH 1/2"x8" LAG SCREWS WITH 2 FLAT WASHERS OR (2) 5/8" BOLTS, WITH 4 FLAT WASHERS.
  2. 3"x10" DOUGLAS FIR PLANK (LENGTH TO BE DETERMINED ON PLANS).
  3. WHEN BARRICADE (TYPE "A") IS CONSTRUCTED ON BASED INSTEAD OF POSTS SET INTO THE GROUND, IT MAY BE DESIRABLE TO BALLAST THE BASES WITH SAND BAGS OR BY STAKING TO PROVIDE RESISTANCE TO OVERTURNING DURING PERIODS OF HIGH WINDS.

ALLOWABLE V.C.P. TRENCH LOADING

PIPE SIZE (INCHES)	V.C.P. THREE EDGE BEARING STRENGTH MIN.	ALLOWABLE TRENCH LOAD PER CLASS OF BEDDING SOIL WT.=130#/CU.FT. SAFETY FACTOR=1.5	
		CLSM L.F.=2.8	ABC L.F.=2.2
8	2200	4107	3227
10	2400	4480	3520
12	2600	4853	3813
15	2900	5413	4253
18	3300	6160	4840
21	3850	7187	5647
24	4400	8213	6453
27	4700	8773	6893
30	5000	9333	7333
33	5500	10267	8067
36	6000	11200	8800
39	6600	12320	9680
42	7000	13067	10267

V.C.P. BEDDING DETAILS

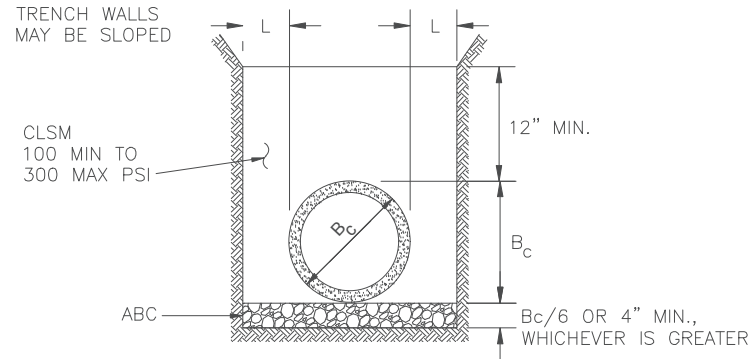

L = 9" MIN. for Pipe Dia. 8" to 21"  
L = 12" MIN. for Pipe Dia. 24" and greater

CLSM

LOAD FACTOR: 2.8 CONTROLLED LOW STRENGTH MATERIAL (CLSM)

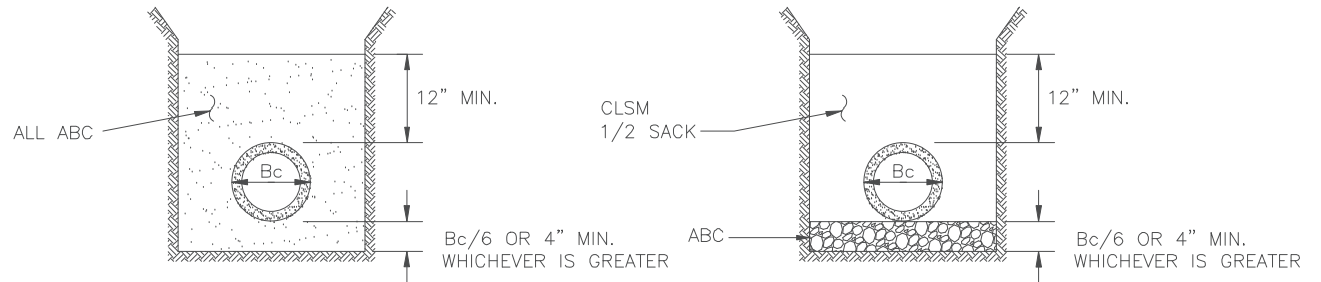

ABC OR 1/2 SACK CLSM

LOAD FACTOR: 2.2 AGGREGATE BASE COURSE (ABC) ENCASEMENT

NOTES:

- CITY SUPPLEMENT SECTION 601 APPLIES FOR FOUNDATION, BEDDING, BACKFILL, MATERIALS AND COMPACTION.
- CLSM PER MAG AND CITY SUPPLEMENT SECTION 728
- Bc = OUTSIDE DIAMETER OF PIPE BARREL.

DETAIL NO.  
P1120



**City of Phoenix**  
**STANDARD DETAIL**

V.C.P. TRENCH LOADING

APPROVED

*Eva J. Flores*  
CITY ENGINEER

04/01/2022  
DATE

DETAIL NO.  
P1120

8" V.C.P. 3 EDGE BEARING STRENGTH=2200#/L.F.

FILL OVER TOP OF PIPE (FT.)	TRENCH WIDTH AT TOP OF PIPE						FILL OVER TOP OF PIPE (FT.)
	18"	24"	30"	36"	42"	WIDER THAN 42"	
	CLASS OF BEDDING						
6	ABC OR 1/2 SACK CLSM						6
8							
10							
12							
14							
16							
18							
20							
22							
24							
	CLSM 100 MIN - 300 MAX PSI						

10" V.C.P. 3 EDGE BEARING STRENGTH=2400#/L.F.

FILL OVER TOP OF PIPE (FT.)	TRENCH WIDTH AT TOP OF PIPE						FILL OVER TOP OF PIPE (FT.)
	24"	30"	36"	42"	48"	WIDER THAN 48"	
	CLASS OF BEDDING						
6	ABC OR 1/2 SACK CLSM						6
8							
10							
12							
14							
16							
18							
20							
22							
24							
	CLSM 100 MIN - 300 MAX PSI						

- SEE DETAIL P1120 FOR BEDDING DETAILS
- FILL DEPTH GREATER THAN 25 FEET OVER TOP OF PIPE REQUIRE A SEALED ENGINEERED DESIGN

DETAIL NO.  
P1121



**City of Phoenix**  
**STANDARD DETAIL**

8" & 10" V.C.P. TRENCH LOADING

APPROVED

*Evo J. [Signature]*

12/13/2024  
DATE

DETAIL NO.  
P1121

12" V.C.P. 3 EDGE BEARING STRENGTH=2600#/L.F.

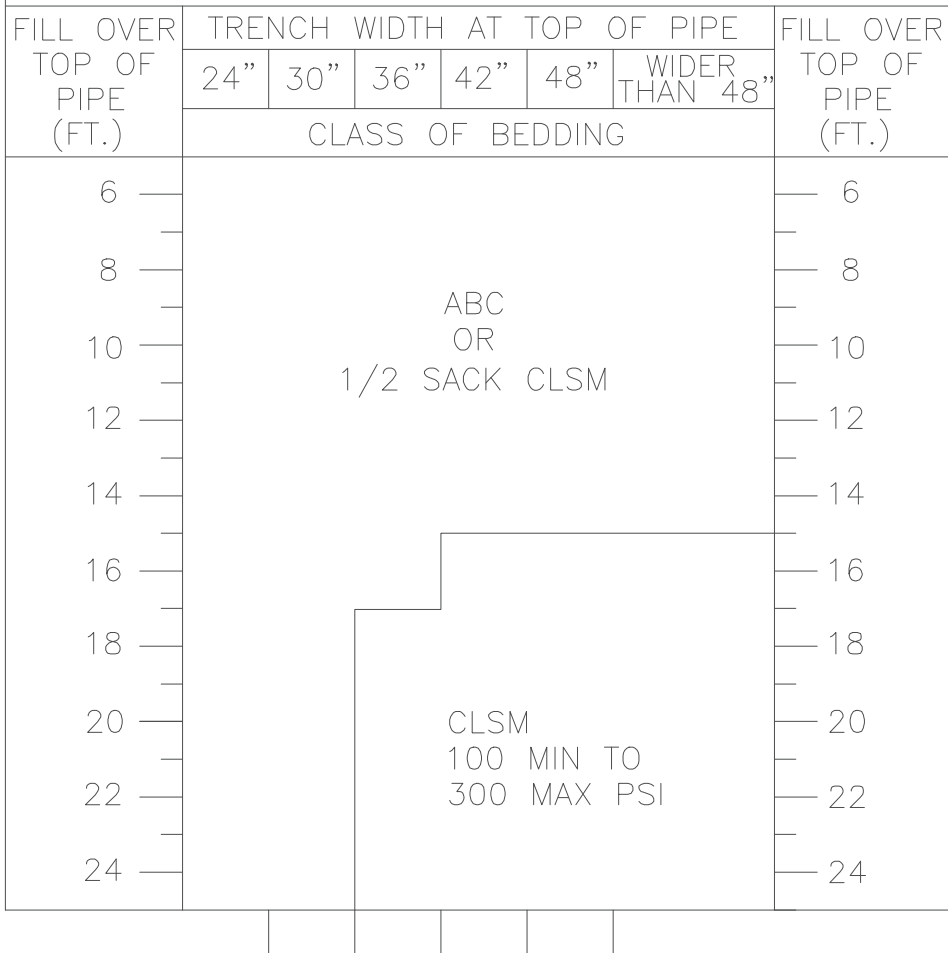

15" V.C.P. 3 EDGE BEARING STRENGTH=2900#/L.F.

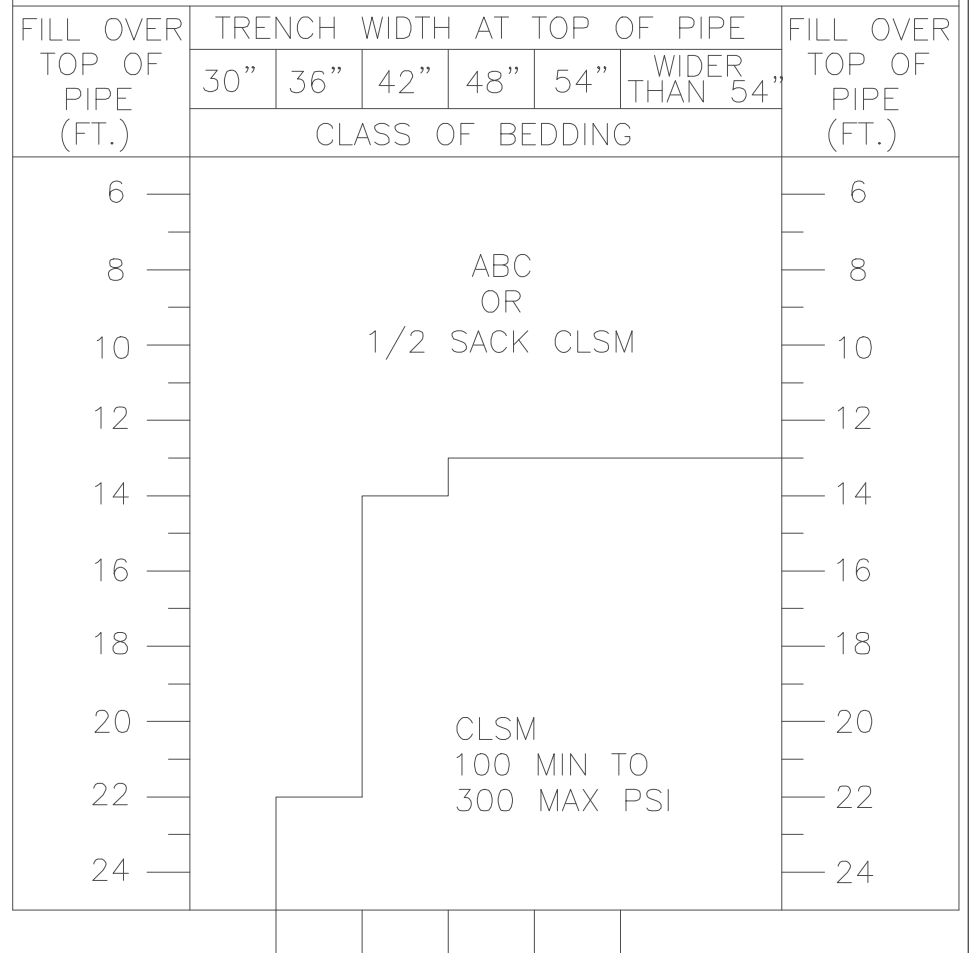

- SEE DETAIL P1120 FOR BEDDING DETAILS
- FILL DEPTH GREATER THAN 25 FEET OVER TOP OF PIPE REQUIRE A SEALED ENGINEERED DESIGN

DETAIL NO.  
P1122



**City of Phoenix**  
**STANDARD DETAIL**

12" & 15" V.C.P. TRENCH LOADING

APPROVED

*Evo Flores*

12/13/2024  
DATE

DETAIL NO.  
P1122

18" V.C.P. 3 EDGE BEARING STRENGTH=3300#/L.F.

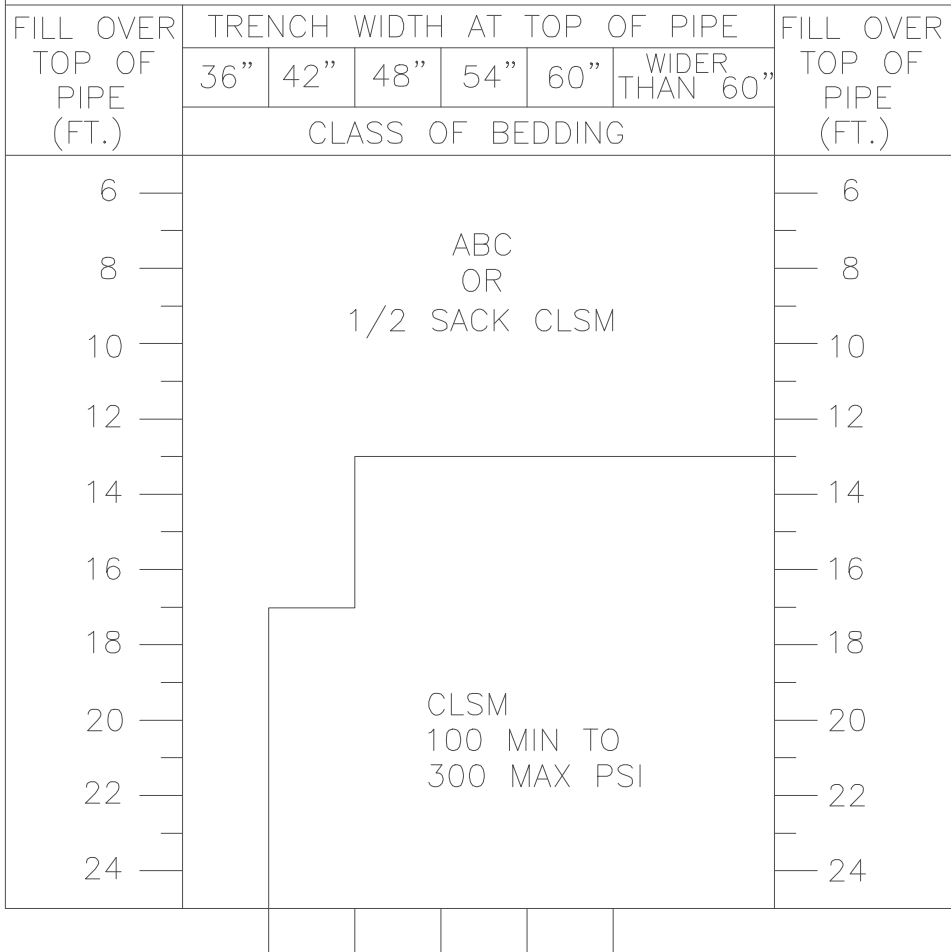

21" V.C.P. 3 EDGE BEARING STRENGTH=3850#/L.F.

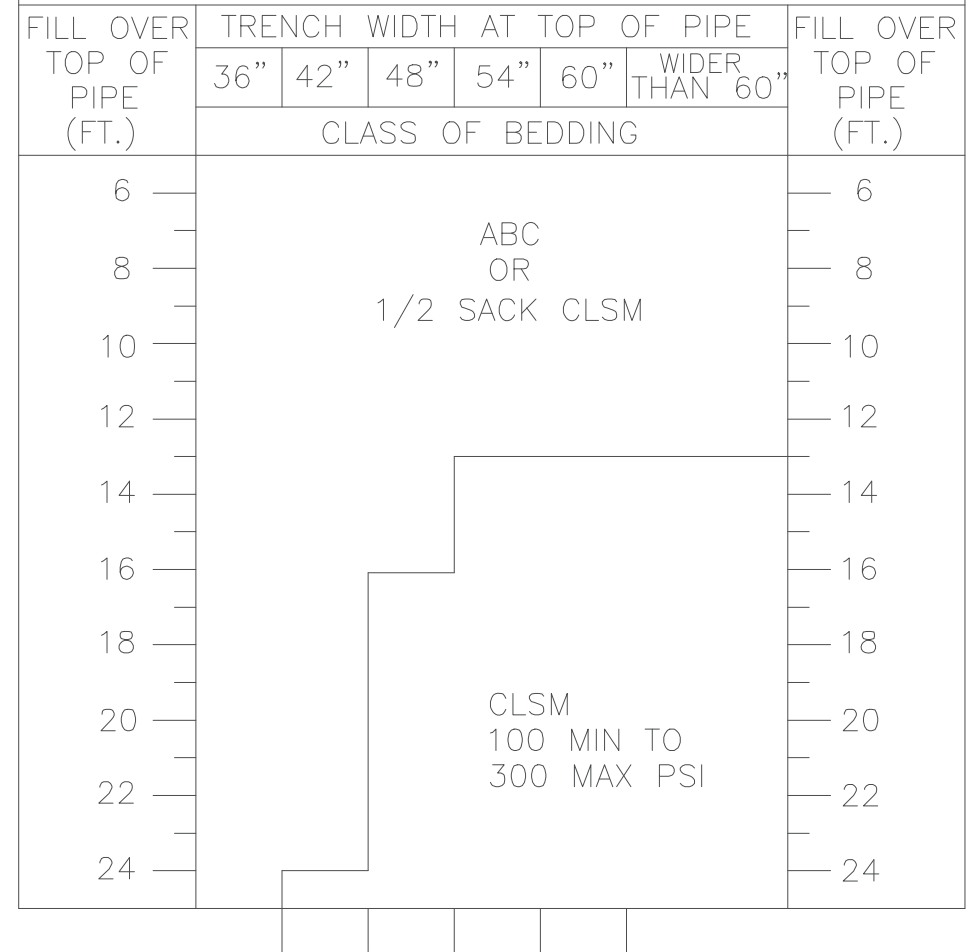

- SEE DETAIL P1120 FOR BEDDING DETAILS
- FILL DEPTH GREATER THAN 25 FEET OVER TOP OF PIPE REQUIRE A SEALED ENGINEERED DESIGN

DETAIL NO.  
P1123



**City of Phoenix**  
**STANDARD DETAIL**

18" & 21" V.C.P. TRENCH LOADING

APPROVED

*Evo Flores*

12/13/2024  
DATE

DETAIL NO.  
P1123



24" V.C.P. 3 EDGE BEARING STRENGTH=4400#/L.F.

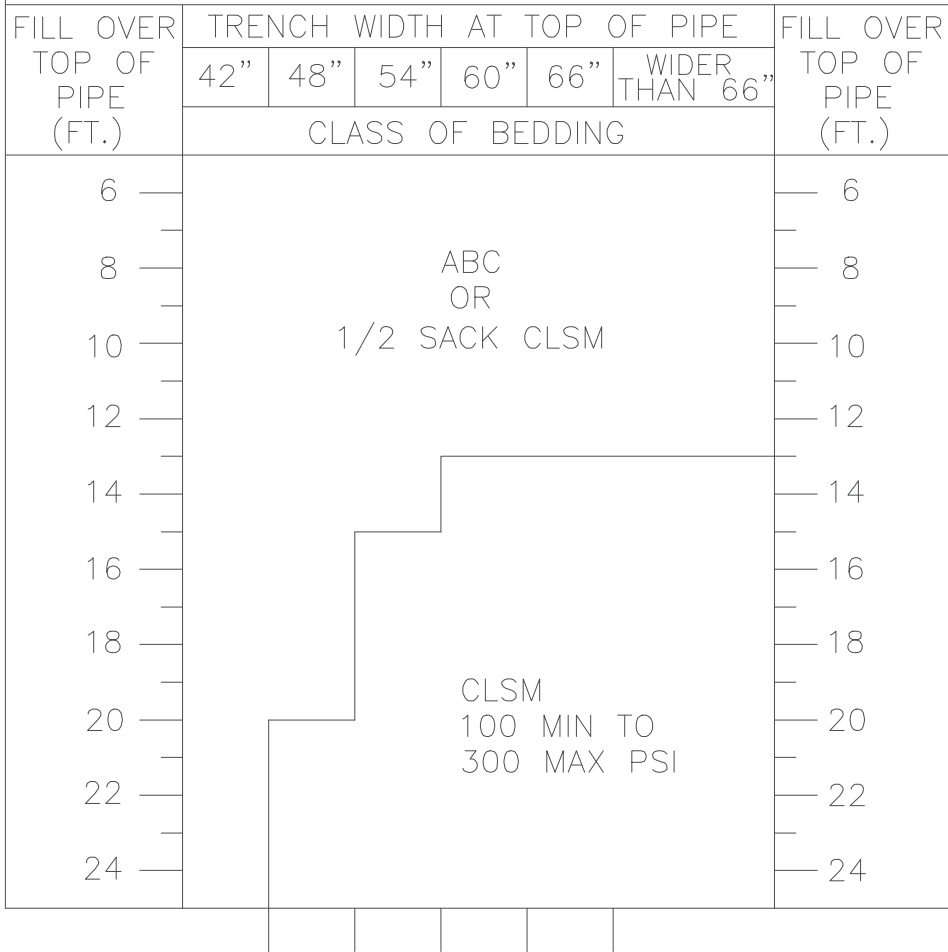

27" V.C.P. 3 EDGE BEARING STRENGTH=4700#/L.F.

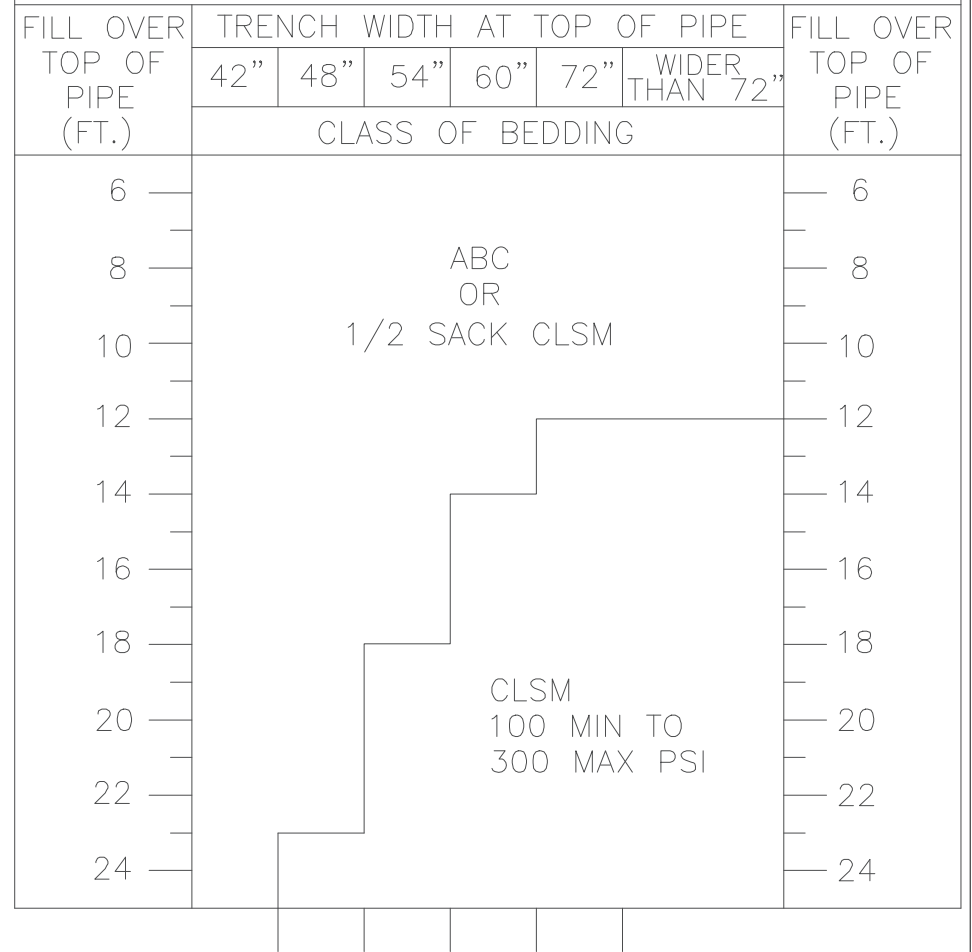

- SEE DETAIL P1120 FOR BEDDING DETAILS
- FILL DEPTH GREATER THAN 25 FEET OVER TOP OF PIPE REQUIRE A SEALED ENGINEERED DESIGN

DETAIL NO.  
P1124



**City of Phoenix**  
**STANDARD DETAIL**

24" & 27" V.C.P. TRENCH LOADING

APPROVED

*EcoFlow*

12/13/2024  
DATE

DETAIL NO.  
P1124

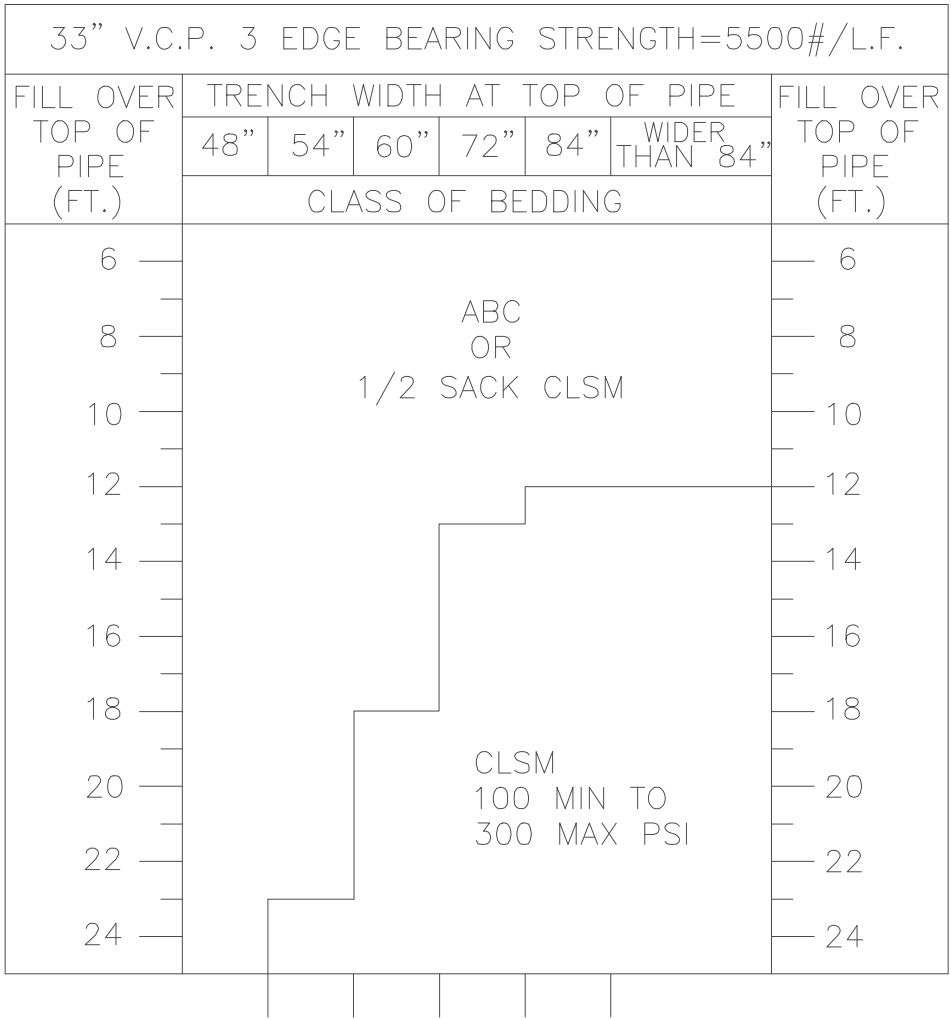
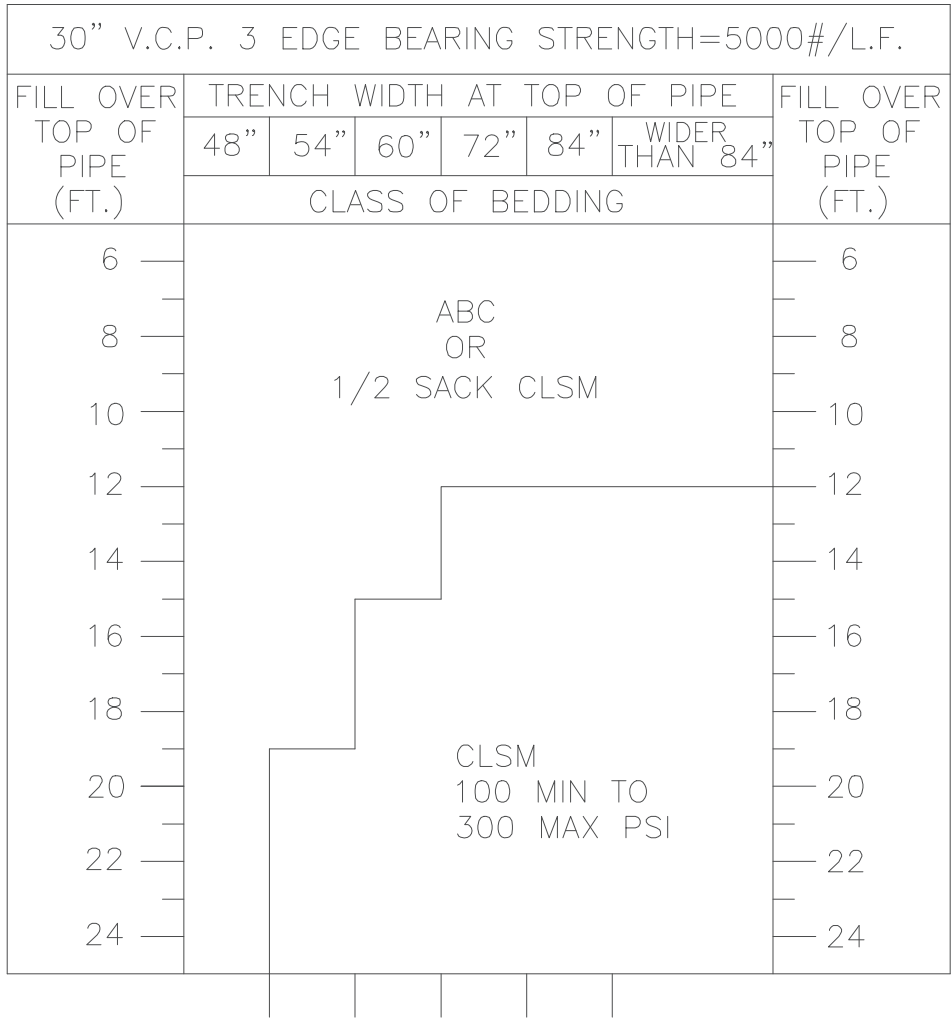

- SEE DETAIL P1120 FOR BEDDING DETAILS
- FILL DEPTH GREATER THAN 25 FEET OVER TOP OF PIPE REQUIRE A SEALED ENGINEERED DESIGN

36" V.C.P. 3 EDGE BEARING STRENGTH=6000#/L.F.

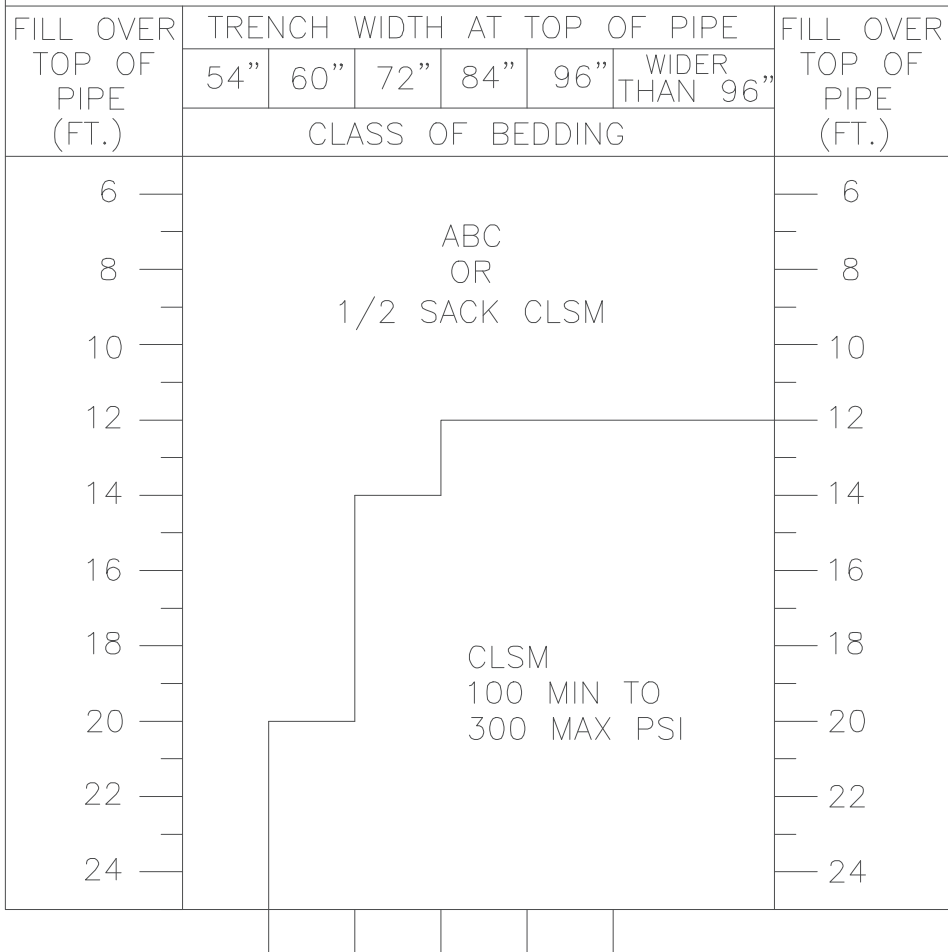

39" V.C.P. 3 EDGE BEARING STRENGTH=6600#/L.F.

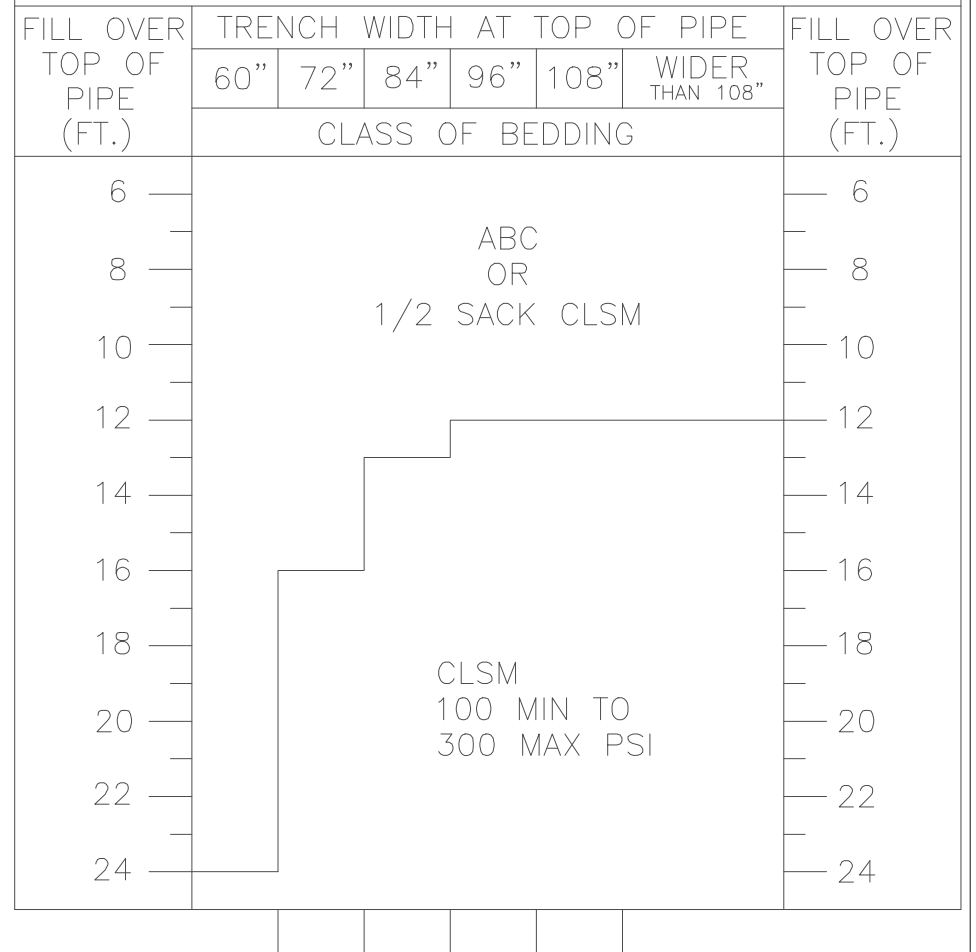

- SEE DETAIL P1120 FOR BEDDING DETAILS
- FILL DEPTH GREATER THAN 25 FEET OVER TOP OF PIPE REQUIRE A SEALED ENGINEERED DESIGN

DETAIL NO.  
P1126



**City of Phoenix**  
**STANDARD DETAIL**

36" & 39" V.C.P. TRENCH LOADING

APPROVED

*Eero J. Hiltunen*

12/13/2024  
DATE

DETAIL NO.  
P1126

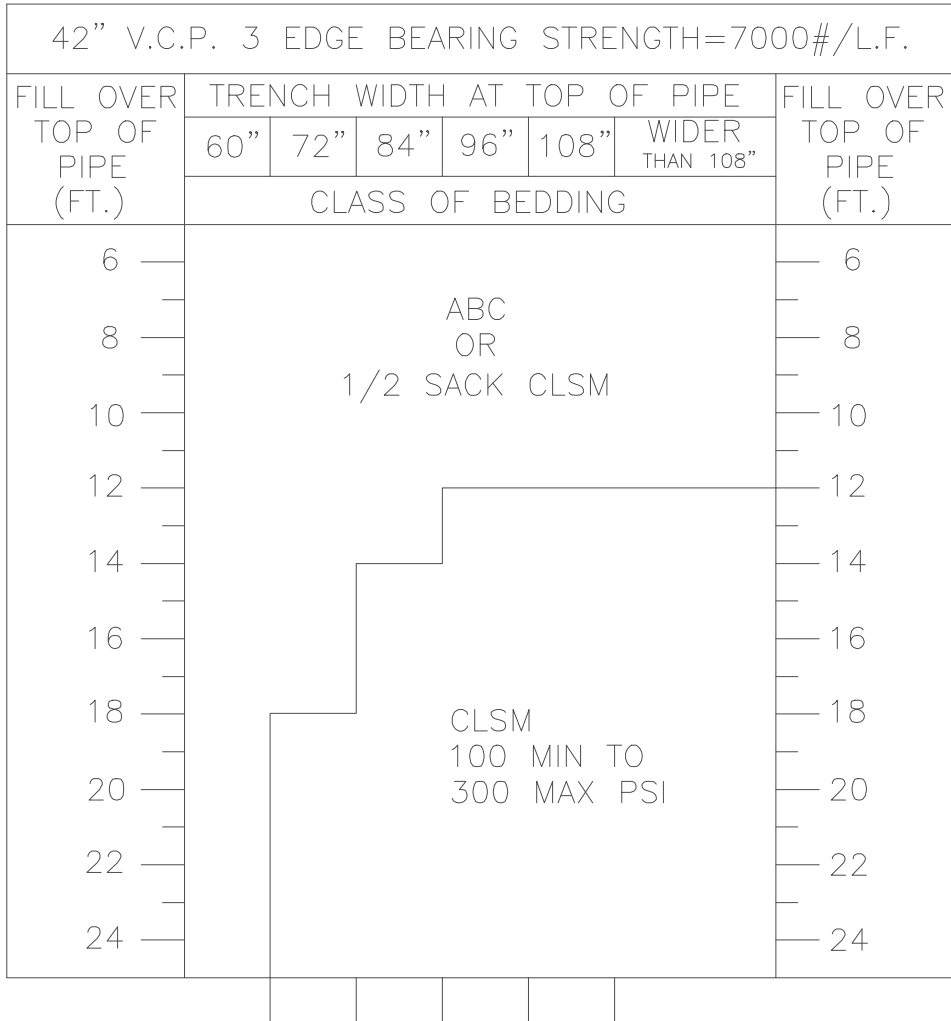

- SEE DETAIL P1120 FOR BEDDING DETAILS
- FILL DEPTH GREATER THAN 25 FEET OVER TOP OF PIPE REQUIRE A SEALED ENGINEERED DESIGN

DETAIL NO.  
P1127



**City of Phoenix**  
**STANDARD DETAIL**

42" V.C.P. TRENCH LOADING

APPROVED

12/13/2024  
DATE

DETAIL NO.  
P1127

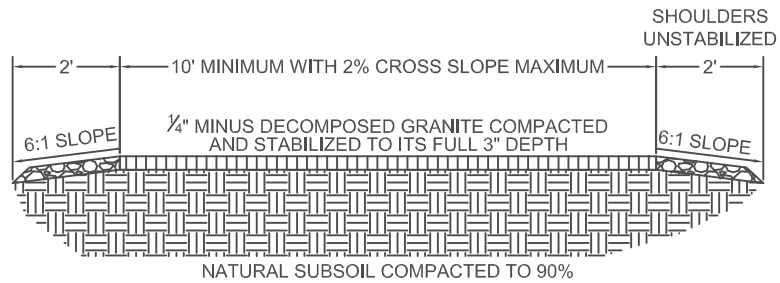

NOT TO SCALE

MULTI-USE TRAIL IN DECOMPOSED GRANITE

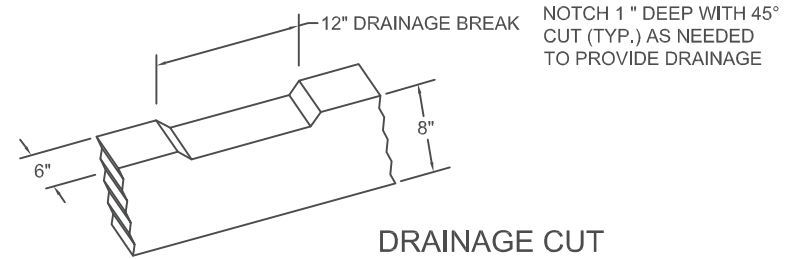

DRAINAGE CUT

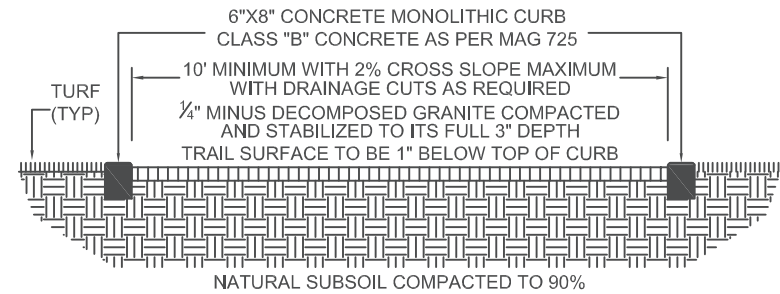

NOT TO SCALE

MULTI-USE TRAIL IN TURF

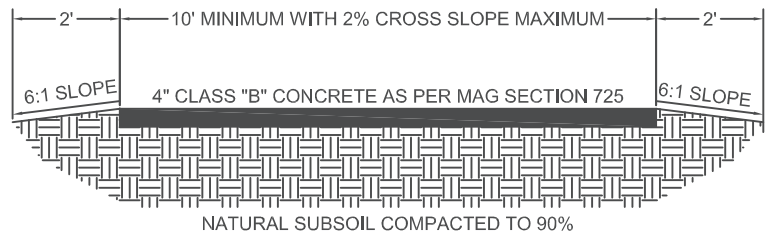

NOT TO SCALE

SHARED USE PATH

NOTES:

1. NO RUNNING SLOPE SHALL EXCEED 5%. IF RUNNING SLOPE EXCEEDS 5%, TRAIL MUST CONFORM TO AMERICANS WITH DISABILITIES ACT GUIDELINES.
2. TRAILS WILL NOT EXCEED 8% SLOPES, SLOPES 5-8% NOT TO EXCEED 30' DISTANCE WITHOUT 5' LANDING. REFER TO U.S. DEPARTMENT OF JUSTICE WEBSITE FOR MORE INFORMATION.
3. SHARED-USE PATH WILL FOLLOW P1230 SIDEWALK DETAILS & SPECIFICATIONS FOR CONCRETE SIDEWALK.
4. MULTI-USE TRAIL TO BE LOCATED WITH AN EXCLUSIVE MINIMUM 30' PUBLIC MULTI-USE TRAIL EASEMENT THAT MAY INCLUDE A PUE.
6. SHARED-USE PATH TO BE LOCATED WITHIN A 20' PUBLIC SIDEWALK EASEMENT.
7. MULTI-USE TRAILS AND SHARED-USE PATHS LOCATED WITHIN OR ADJACENT TO OPEN SPACE OR WASH CORRIDORS WILL BE LOCATED WITHIN A MINIMUM 25' PUBLIC TRAIL EASEMENT.
8. REFERS TO CITY OF PHOENIX SUPPLEMENTS SECTION 429 FOR ADDITIONAL REQUIREMENTS

DETAIL NO.  
P1130



**City of Phoenix**  
**STANDARD DETAIL**

MULTI-USE TRAILS  
AND SHARED-USE PATHS

APPROVED

*Eva...*  
CITY ENGINEER

04/01/2022  
DATE

DETAIL NO.  
P1130

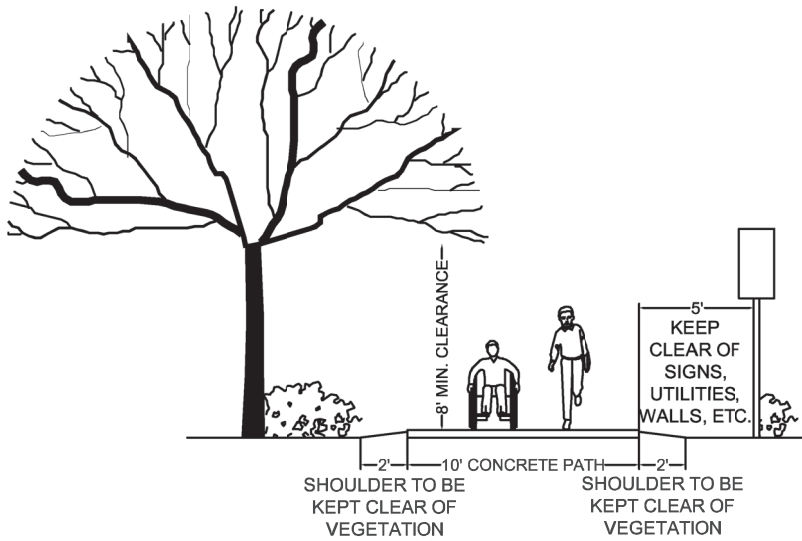

NOT TO SCALE  
**SHARED-USE PATHS - OBSTRUCTION CLEARANCES**

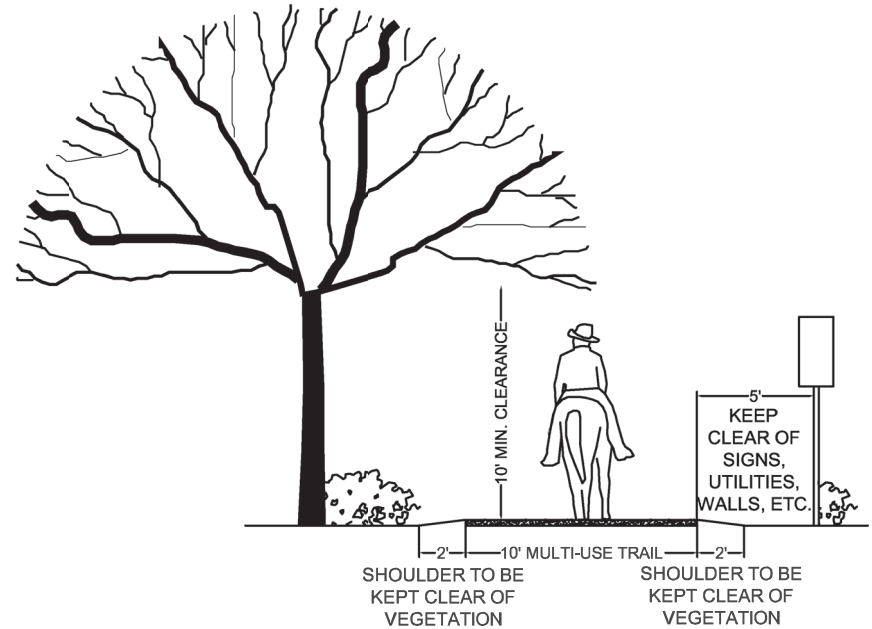

NOT TO SCALE  
**MULTI-USE TRAILS - OBSTRUCTION CLEARANCES**

REFER TO CITY OF PHOENIX SUPPLEMENTS SECTION 429

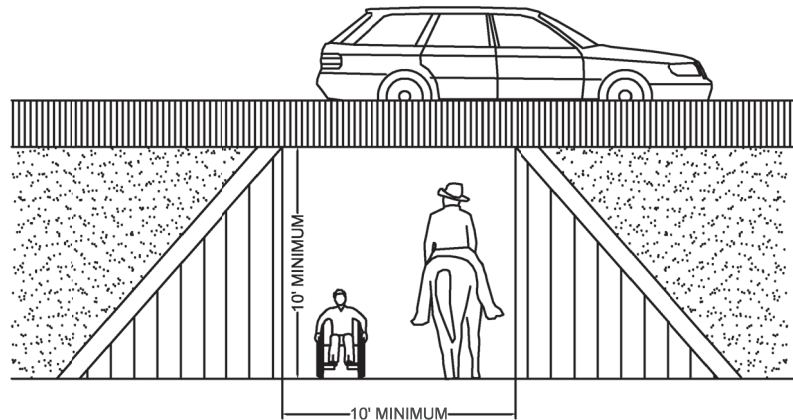

PLANTS WITH THORNS SUCH AS CACTI, ACACIA & DASYLIRION SPECIES ETC., SHALL NOT BE PLANTED OR ALLOWED TO GROW WITHIN 10-FEET OF MUT&SUP

NOT TO SCALE  
**UNDERPASS DIMENSIONS**

DETAIL NO.  
 P1131



VERTICAL CLEARANCE, MULTI-USE, SHARED-USE,  
 AND UNDERPASS/BRIDGE CLEARANCE

APPROVED

*Eva Alvarez*  
 CITY ENGINEER

REVISED 9/08/21

04/01/2022  
 DATE

DETAIL NO.  
 P1131

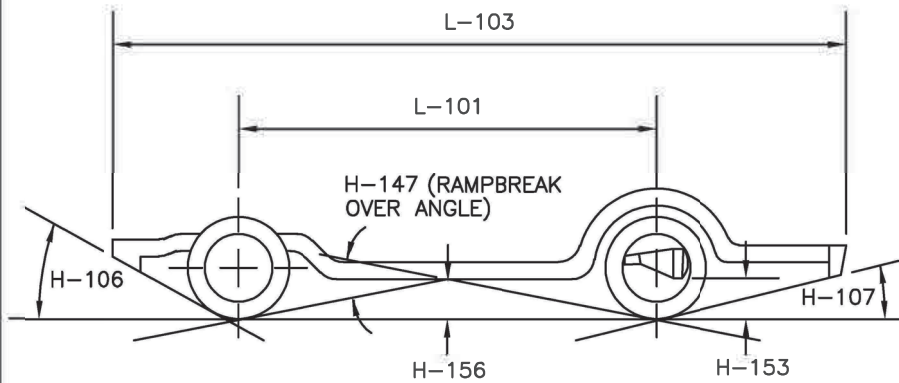

## NOTES

1. IF THE SUM OF THE STREET CROWN SLOPE, NORMALLY A NEGATIVE SLOPE OF 1.72' (0.03), AND THE POSITIVE SLOPE IF THE DRIVEWAY IS EQUAL TO OR EXCEEDS THE ANGLE OF DEPARTURE, 8.3' (0.146), THE DRIVEWAY MUST BE REDESIGNED TO A POSITIVE SLOPE OF NOT MORE THAN 6' (0.105).
2. ADDITIONAL INCREASES IN THE POSITIVE SLOPE MAY BE MADE AT TEN (10) FOOT INTERVALS. EACH CHANGE CANNOT EQUAL OR EXCEED THE ANGLE OF DEPARTURE, 8.3' (0.146).
3. CHANGES FROM A POSITIVE SLOPE TO A NEGATIVE SLOPE CANNOT EQUAL OR EXCEED THE BREAKOVER ANGLE OF 5.53' (0.097).
4. WHEN MAKING CHANGE FROM A NEGATIVE SLOPE TO A POSITIVE SLOPE, THE SUM OF THE TWO SLOPES CANNOT EQUAL OR EXCEED THE ANGLE OF DEPARTURE, 8.3' (0.146).
5. APPLICABLE WHEN P1255 NOT UTILIZED OR AS REQUIRED BY ENGINEER.

## GROUND CLEARANCE DIMENSIONS

H-106 - ANGLE OF APPROACH = 8.6 DEGREES  
 H-107 - ANGLE OF DEPARTURE = 8.3 DEGREES  
 H-147 - RAMP BREAKOVER ANGLE = 5.53 DEGREES  
 H-153 - REAR AXLE TO GROUND = 5.5 INCHES  
 H-156 - MINIMUM GROUND CLEARANCE = 3.1 INCHES  
 L-101 - WHEELBASE = 9.88 FEET  
 L-103 - VEHICLE LENGTH = 18.42 FEET

THESE DIMENSIONS ARE FROM THE 1982 MOTOR VEHICLE MANUFACTURERS ASSOCIATION PUBLICATION. COPIES MAY BE OBTAINED FROM TECHNICAL AFFAIRS DIVISION, MOTOR VEHICLE MANUFACTURERS ASSOCIATION, 300 NEW CENTER BUILDING, DETROIT, MICHIGAN 48202.

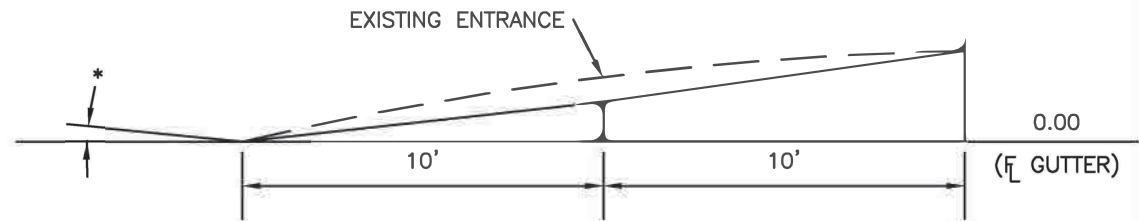

\* 0.03% MAXIMUM TRANSVERSE SLOPE ALLOWABLE

DETAIL NO.  
P1164



**City of Phoenix**  
**STANDARD DETAIL**

MAXIMUM DRIVEWAYS & ALLEYS SLOPE

APPROVED

*Eva...*  
CITY ENGINEER

04/01/2022  
DATE

DETAIL NO.  
1164

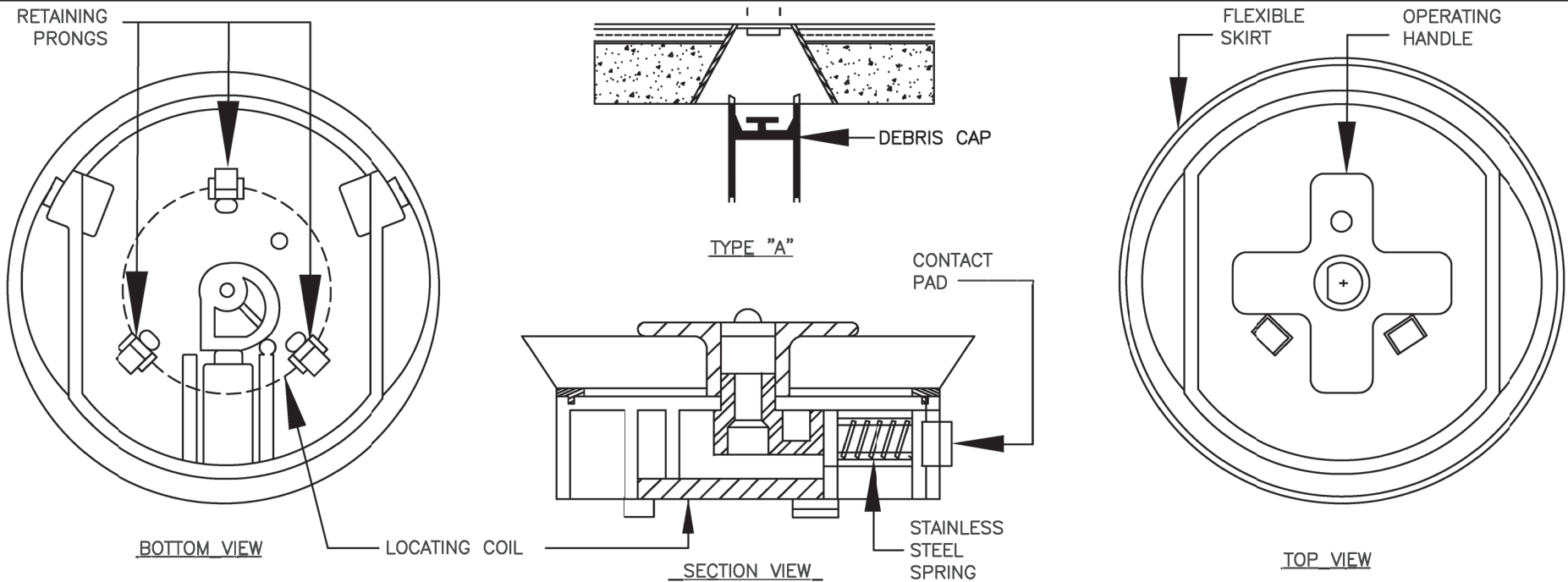

NOTES

1. DEBRIS CAP SHALL BE INSTALLED AS CLOSE UNDER THE CAST IRON COVER WITHOUT INTERFERING WITH COVER OPERATION.
2. FLEXIBLE SKIRT SHALL BE TRIMMED TO PROVIDE A SMOOTH CONTACT WITH THE INTERIOR DIAMETER OF THE PIPE.
3. THE DEBRIS CAP SHALL BE MANUFACTURED BY SW SERVICES, INC., PHOENIX, ARIZONA OR APPROVED EQUAL.
4. THE DEBRIS CAP SHALL BE COMPRISED OF A HOLLOW MEMBER HAVING A CYLINDRICAL OUTER SURFACE, A CLOSURE FOR ONE END AND THREE POINT RESILIENT CONTACT PADS PROJECTING FROM THE OUTER SURFACE. THE CAP SHALL HAVE A FLEXIBLE SKIRT PROVIDING AN OUTWARD SEAL PREVENTING DEBRIS FROM GETTING PAST THE CAP. THE CAP MUST WITHSTAND, WITHOUT SLIPPAGE, A MINIMUM VERTICAL FORCE OF 50 POUNDS, AT A LOADING RATE OF 1.0 IN/MINUTE. THE CAP SHALL BE MOLDED USING GENERAL ELECTRIC ABS #HIM 4500. THE CAP SHALL HAVE RETAINING PRONGS TO RETAIN A STANDARD LOCATING COIL. SCOTCHMARK 4" DISC MARKER 141.7khz BY 3M, OR APPROVED EQUAL.
5. DEBRIS CAPS WITH LOCATOR COILS ARE TO BE INSTALLED IN THE FOLLOWING VALVE BOX LOCATIONS:

STREETS WITH INVERTED CROWNS  
 ANY UNPAVED AREAS  
 ALL EASEMENTS  
 GUTTER LOCATIONS  
 STREETS WITHOUT CURB & GUTTER  
 COUNTY ROADS  
 ANY OTHER LOCATION INDICATED ON THE PLANS PER THE DESIGNER



**NOTES:**

1. PROVIDE 2' MIN. OVERLAP OF PLATE ON ASPHALT TO ASSURE NO SLIPPAGE OF PLATE AND NO COLLAPSING OF TRENCH.
2. "POSTED SPEED" DOES NOT INCLUDE TEMPORARY CONSTRUCTION SIGNING.
3. METHOD OF ASPHALT REMOVAL OTHER THAN MILLING AT INSPECTOR'S DISCRETION ONLY.

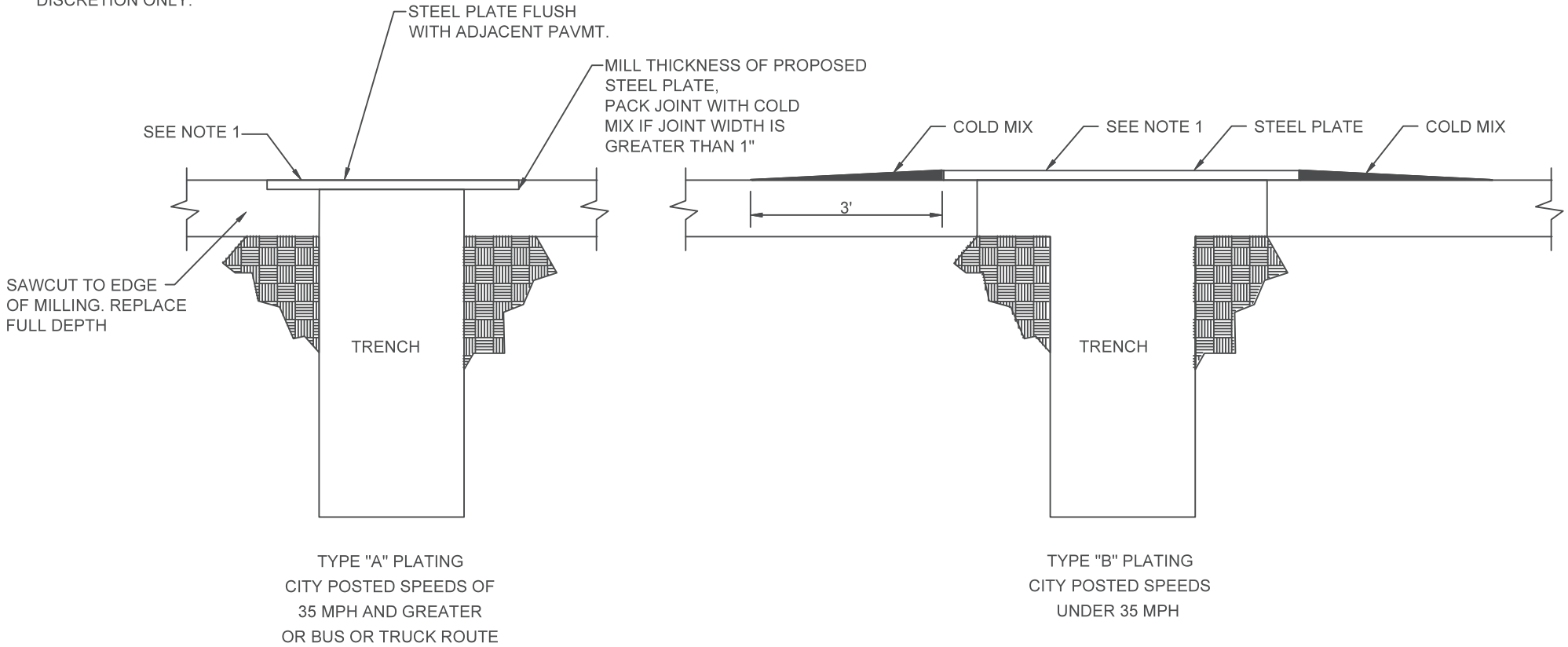

IF TRENCH LENGTH IS LESS THAN 5-FEET AND STEEL PLATES WILL BE IN PLACE LESS THAN 48 HOURS, STEEL PLATES MAY BE PLACED DIRECTLY ON EXISTING ASPHALT WITHOUT MILLING. PROVIDE TEMPORARY ASPHALT TRANSITIONS EXTENDING 3-FEET BEYOND EDGE OF STEEL PLATES.

DETAIL NO.  
P1170



**City of Phoenix**  
**STANDARD DETAIL**

TRENCHING STEEL PLATE

APPROVED

*Maria S. Demando*  
CITY ENGINEER

7/9/92  
DATE

DETAIL NO.  
P1170

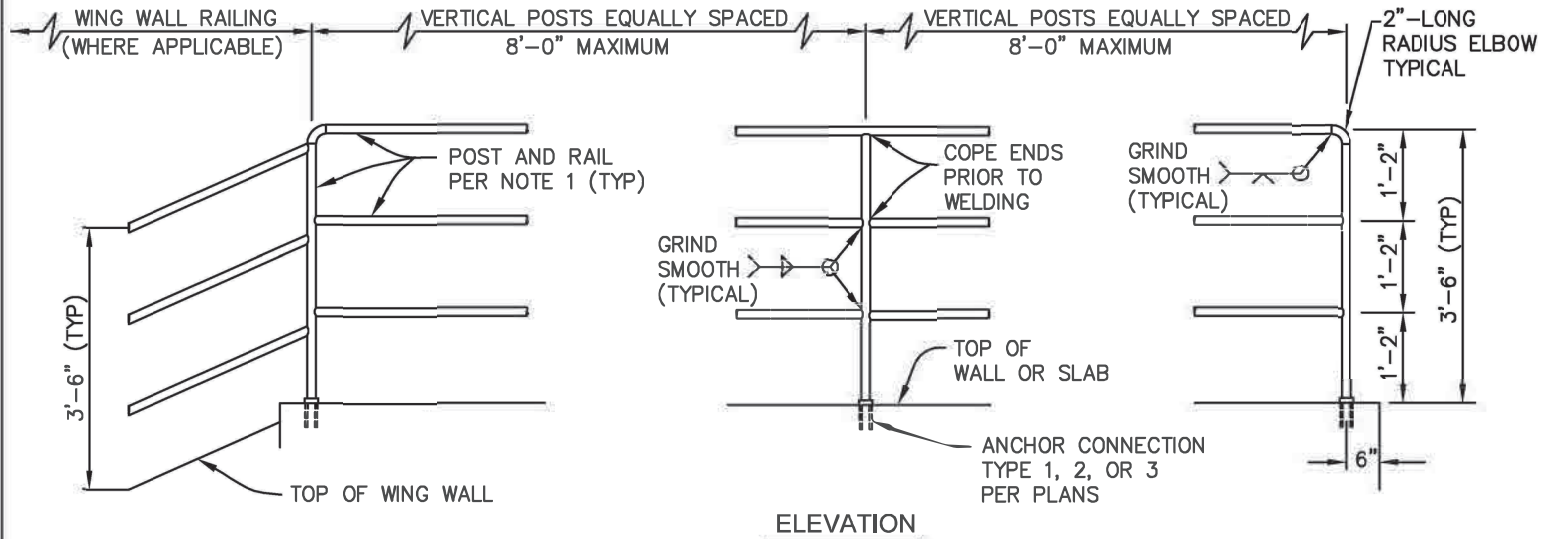

**CONSTRUCTION NOTES**

1. PIPE 2 STD (ASTM A53 GRADE B) GALVANIZED PER SECTION 771.
2. PAINT PER SECTION 530 WHERE REQUIRED BY ORDINANCE OR PLANS. COLOR PER PLANS.
3. VERTICAL POSTS TO BE EVENLY SPACED.
4. RAILING TO BE PLACED ON ALL HEADWALLS AND AT THE BACK OF SCUPPERS.
5. ANCHORAGE AT SCUPPERS SHALL BE PER MAG STD DETAIL 206-2.
6. EXPANSION JOINT SPACING SHALL NOT EXCEED 40FT AND SHALL BE LOCATED AT STRUCTURE EXPANSION JOINTS, WHICHEVER IS LESS.

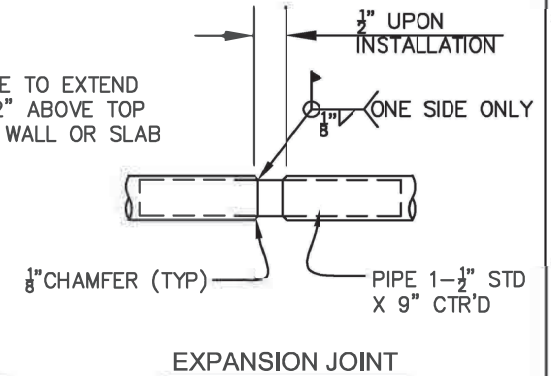
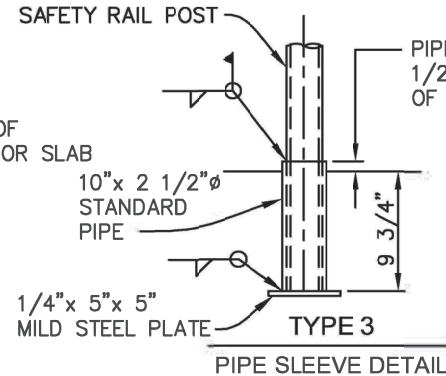
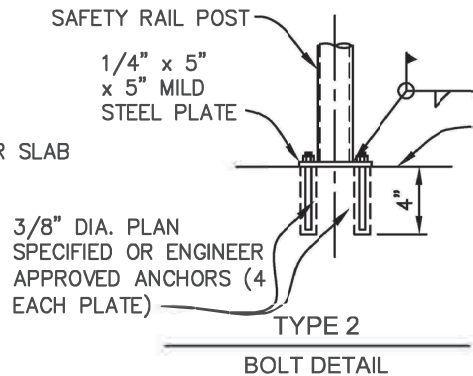
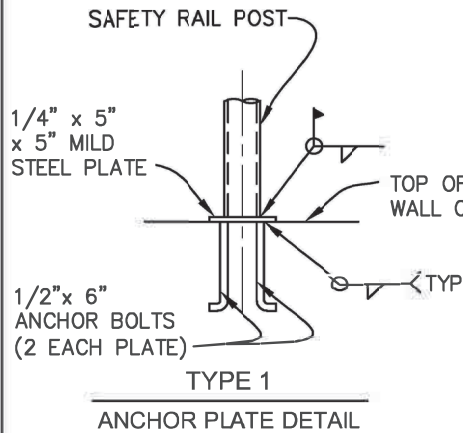

**NOTES:**

1. FOR GROUND INSTALLATION REFER TO MAG STD DETAIL 145.
2. NOT TO BE USED AS A PEDESTRIAN BRIDGE RAIL.

**CONDITIONS WHERE SAFETY RAILINGS (DETAIL P1173) ARE REQUIRED**  
**(REFER TO SAFETY RAILING MAG DETAIL 145, TYPE 4 FOR ATTACHMENT TO THE GROUND)**

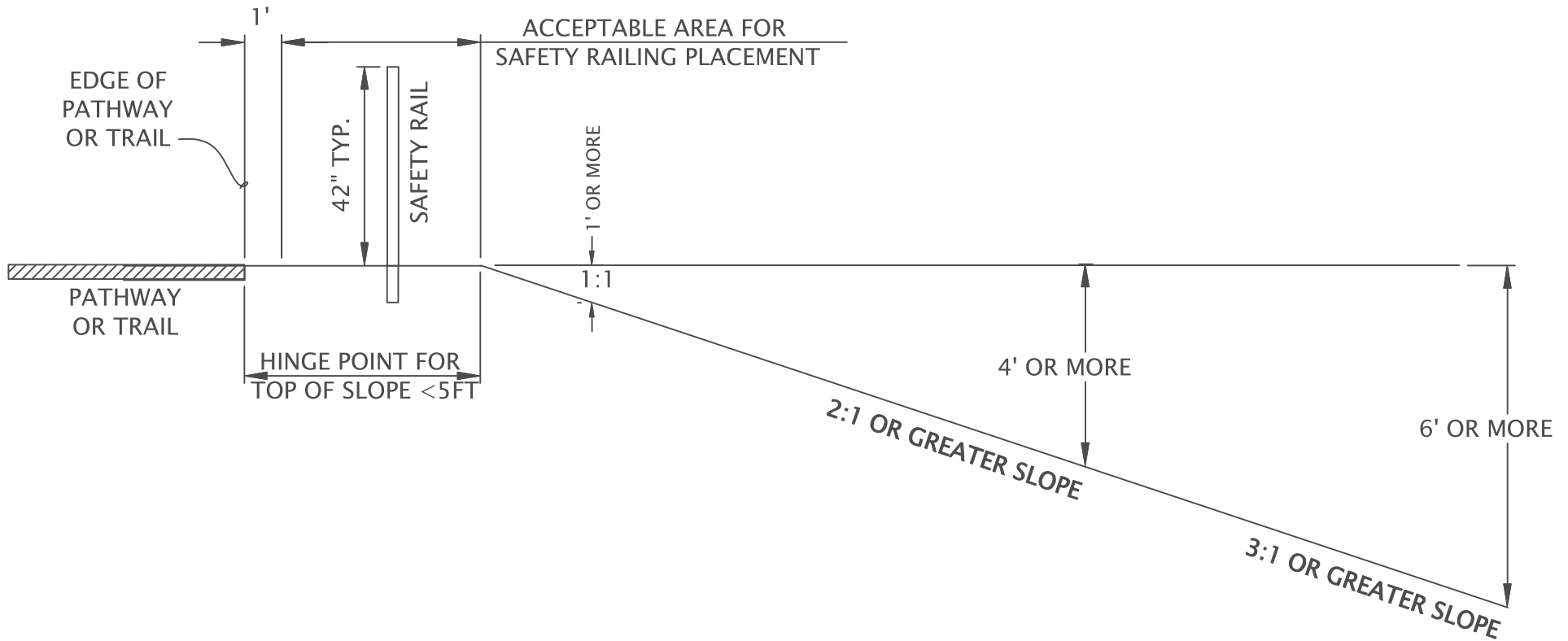

NOTE:  
 1) SAFETY RAILS ARE REQUIRED WHERE THE CONDITIONS WILL EXCEED THE ABOVE DEPICTED LIMITS

NOT TO SCALE

# GENERAL NOTES

## ACCESS

- 1) IN GENERAL TERMS, ALL SOLID WASTE AND RECYCLE COLLECTION ROUTES SHALL MEET ENGINEERING DESIGN CRITERIA IN A MANNER THAT ALLOWS COLLECTION VEHICLES TO SAFELY ACCESS AND LIFT BINS WITHOUT GROUND LEVEL OR AERIAL OBSTRUCTIONS.
- 2) COLLECTION VEHICLE ROUTES SHALL BE A MINIMUM OF 16'-0" WIDE.
- 3) COLLECTION VEHICLE TURNING RADIUS: 44'-0" OUTSIDE TURNING RADIUS AND 28'-6" INSIDE TURNING RADIUS.
- 4) COLLECTION ROUTES SHALL BE ENGINEERED TO ACCOMMODATE COLLECTION VEHICLES THAT ARE 30'-0" LONG AND WEIGH APPROXIMATELY 20 TONS WHEN FULLY LOADED.
- 5) COLLECTION ROUTES SHALL BE DESIGNED SO THAT THE COLLECTION VEHICLE IS REQUIRED TO PASS THROUGH THE SITE A SINGLE TIME WITH NO BACKTRACKING.
- 6) ROUTES SHALL BE CLEAR OF ALL OBSTRUCTIONS. NO AWNING OR BUILDING PROJECTIONS ARE ALLOWED ON COLLECTION ROUTES. MINIMUM OVERHEAD CLEARANCE OF 14'-0" IS REQUIRED FOR COLLECTION ROUTES AND 25'-0" OVER BIN ENCLOSURE AREA FROM STEEL SAFETY POSTS BACK 50'-0".
- 7) ALL CURBS SHALL ALIGN ON THE OUTSIDE OF THE ENCLOSURE WALLS. CURBS SHALL NOT INTERFERE WITH THE ROUTE OF THE COLLECTION VEHICLE.
- 8) BIN ENCLOSURES ARE TO HAVE A MAXIMUM DEVIATION OF 30° FROM THE CENTERLINE OF THE COLLECTION VEHICLE TO THE COLLECTION ROUTE.
- 9) BIN ENCLOSURES SHALL BE LOCATED AWAY FROM ENTRANCES AND EXITS SO COLLECTION VEHICLE DOES NOT CREATE A SAFETY HAZARD BY BLOCKING TRAFFIC.
- 10) BIN ENCLOSURES SHALL BE A MINIMUM OF 5'-0" FROM ANY PLANNED OR EXISTING STRUCTURE AT ITS CLOSEST POINT. REFER TO APPLICABLE FIRE CODE FOR MORE DETAILS.
- 11) COLLECTION VEHICLES SHALL NOT BE REQUIRED TO BACK UP MORE THAN 50' DURING BIN SERVICING.
- 12) FOR CITY OF PHOENIX COLLECTION, A REFUSE COLLECTION EASEMENT WILL BE REQUIRED FOR ANY PORTION OF THE COLLECTION ROUTE NOT LOCATED IN THE PUBLIC RIGHT-OF-WAY.

## CONTAINMENT

- 1) PROVIDE 3'-0" PEDESTRIAN ACCESS GATE INTO ENCLOSURE. ENCLOSURES WITH MIDWALLS REQUIRE ADDITIONAL GATES. GATES MAY BE LOCKABLE.
- 2) SITE APPURTENANCES SUCH AS LANDSCAPING CONTROL BOXES AND LIGHTING MAY BE PLACED ON THE OUTSIDE OF THE ENCLOSURE WALLS.

## USE-SPECIFIC REQUIREMENTS

- 1) RESTAURANTS MUST PROVIDE A SEPARATE ENCLOSED AREA TO ACCOMMODATE THEIR GREASE TRAP(S). THIS DESIGNATED AREA SHALL NOT INTERFERE WITH COLLECTION.
- 2) MULTI-FAMILY DEVELOPMENT SOLID WASTE REQUIREMENT IS ¼-CY PER DWELLING UNIT SERVICED TWICE PER WEEK.
- 3) THE CITY OF PHOENIX REQUIRES RECYCLING CAPACITY FOR NEW MULTI-FAMILY DEVELOPMENTS.
- 4) COMPACTORS MAY BE USED IN DEVELOPMENTS WHERE THE EMPLOYEES LOAD AND ACTIVATE THE COMPACTING EQUIPMENT. DEVELOPMENTS THAT ALLOW CUSTOMERS OR RESIDENTS ACCESS TO THE COMPACTING EQUIPMENT WILL NOT BE APPROVED. CITY OF PHOENIX ALLOWS A 3:1 COMPACTION RATE. GREATER COMPACTION RATES REQUIRE CASE-BY-CASE APPROVAL BASED ON MANUFACTURER'S SPECIFICATIONS. COMPACTION EQUIPMENT SHALL BE SCREENED TO THE HIGHEST POINT OF THE EQUIPMENT.

## USE-SPECIFIC RECOMMENDATIONS

- 1) CITY OF PHOENIX RECOMMENDS PROVIDING RECYCLING CAPACITY EQUAL TO REQUIRED SOLID WASTE CAPACITY FOR COMMERCIAL DEVELOPMENTS AND MULTI-FAMILY DEVELOPMENTS.
- 2) COMMERCIAL PROPERTIES SHOULD BE DESIGNED TO PROVIDE A REFUSE ENCLOSURE FOR EVERY 20,000 SQUARE FEET OF BUILDING SPACE.
- 3) RESTAURANTS WHICH ARE DESIGNED ON A SINGLE PAD SHOULD HAVE A MINIMUM OF ONE REFUSE ENCLOSURE.

\*THIS STANDARD IS BASED ON PHOENIX CITY CODE CHAPTER 27, SOLID WASTE, AND THE TECHNICAL REQUIREMENTS OF CITY OF PHOENIX OPERATED COLLECTION EQUIPMENT.

DETAIL NO.  
P1180



City of Phoenix  
STANDARD DETAIL

GENERAL NOTES

  
CITY ENGINEER

04/01/2022  
DATE

DETAIL NO.  
P1180

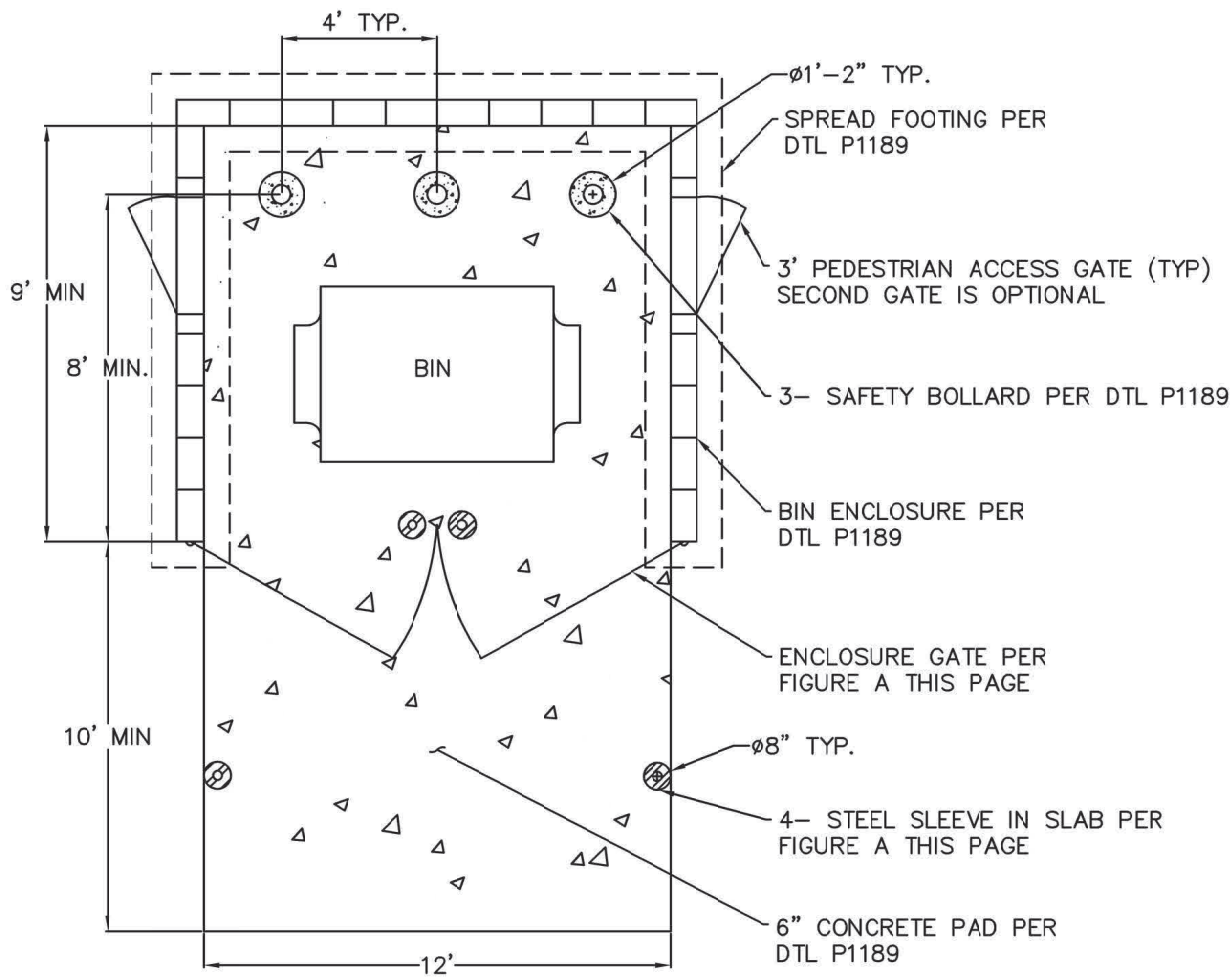

REFUSE AREA - PLAN  
NTS

MAX BIN DEVIATION

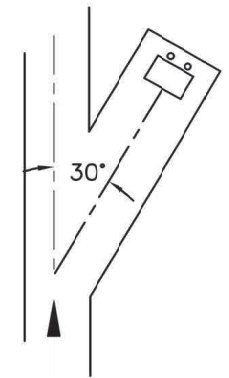

NOTES

- 1) GATES SHALL BE FULL HEIGHT OF SCREEN WALLS.
- 2) GATES SHALL BE DESIGNED TO FULLY SCREEN ENCLOSED BIN.
- 3) OPEN MESH OR RAIL DESIGNS ARE NOT PERMITTED.

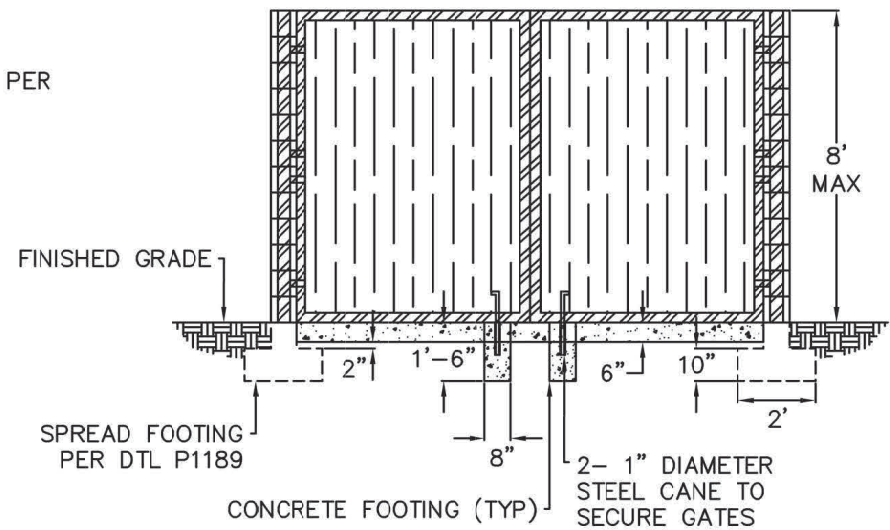

(A) ENCLOSURE GATE - ELEVATION  
NTS



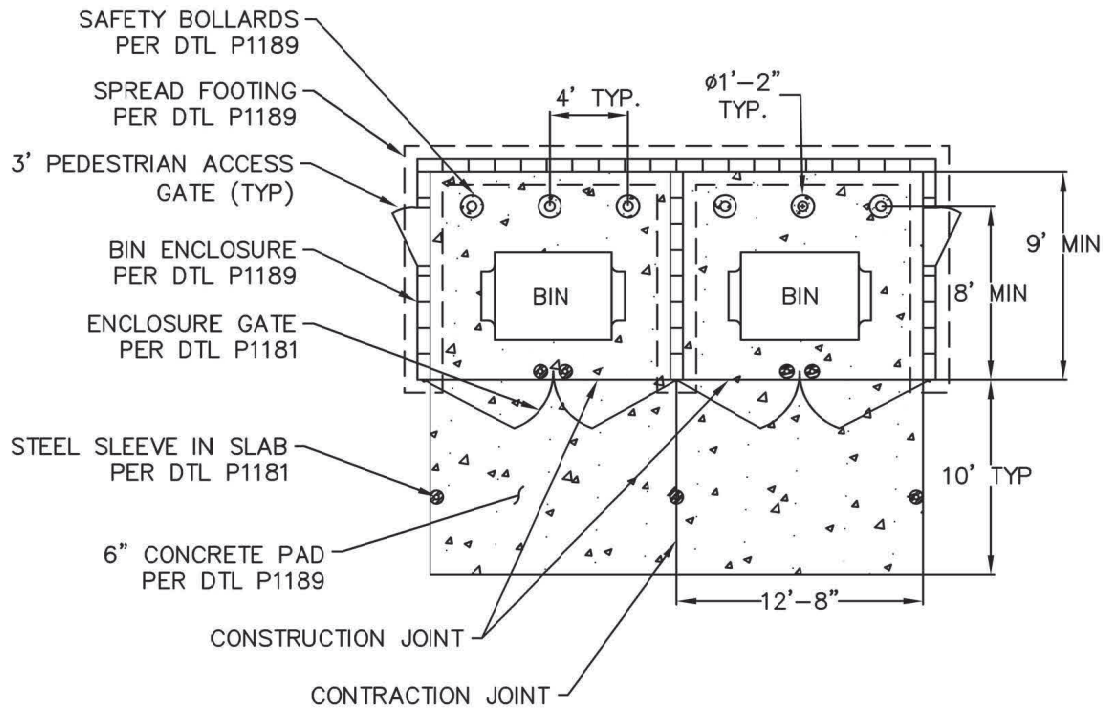

DOUBLE REFUSE AREA

NTS

NOTES:

- 1) GATES, HINGES, AND MOUNTING HARDWARE SHALL NOT INTRUDE UPON MINIMUM NET ENCLOSURE OPENING.
- 2) BINS THAT ARE VISIBLE FROM A PUBLIC ROADWAY SHALL HAVE ENCLOSURE GATES THAT SCREEN THE BINS FROM PUBLIC VIEW.
- 3) BIN ENCLOSURES ARE TO BE A MINIMUM OF 5 FEET FROM ANY PLANNED OR EXISTING STRUCTURE AT ITS CLOSEST POINT. REFER TO APPLICABLE FIRE CODE FOR MORE DETAILS.
- 4) SECOND PEDESTRIAN ACCESS GATES ARE OPTIONAL WITHOUT MIDWALL OR IN OFFSET CONFIGURATION.

MAX BIN DEVIATION

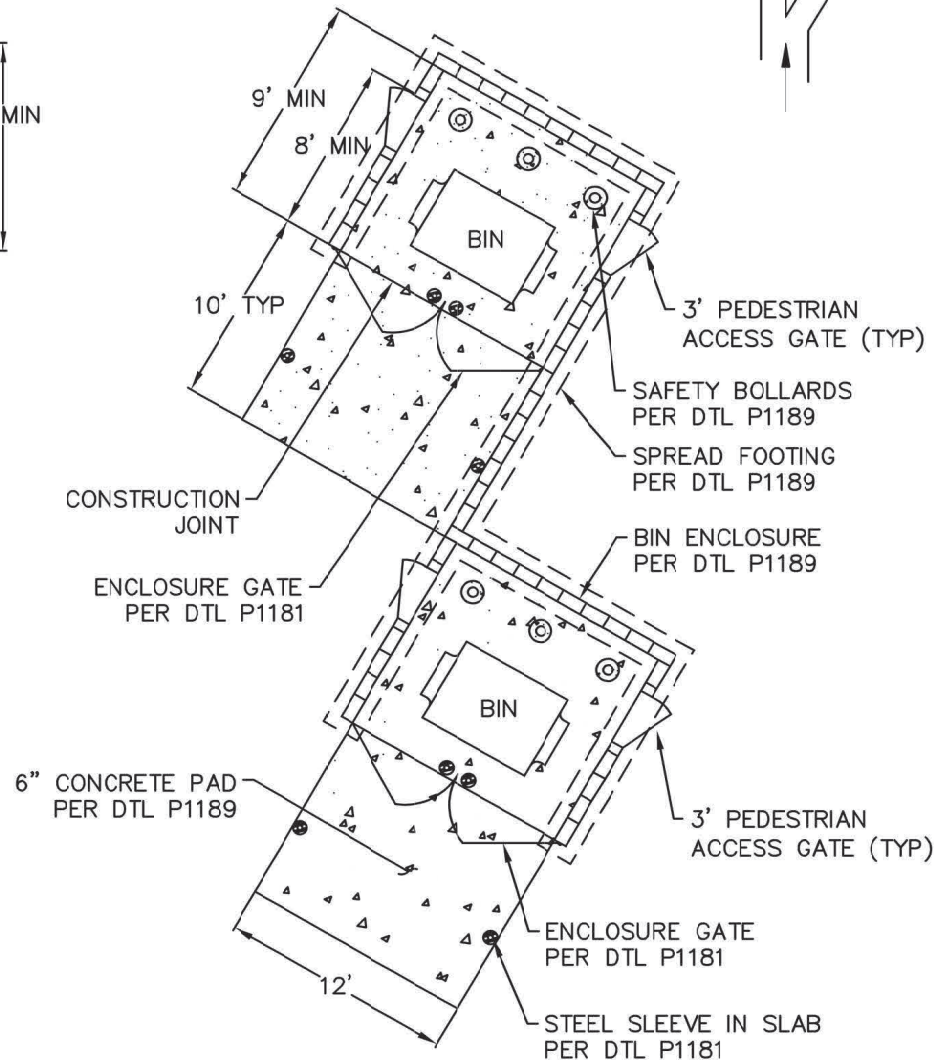
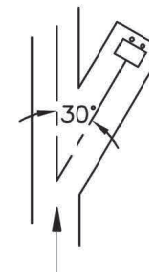

DOUBLE REFUSE AREA - OFFSET

NTS



MAX BIN DEVIATION

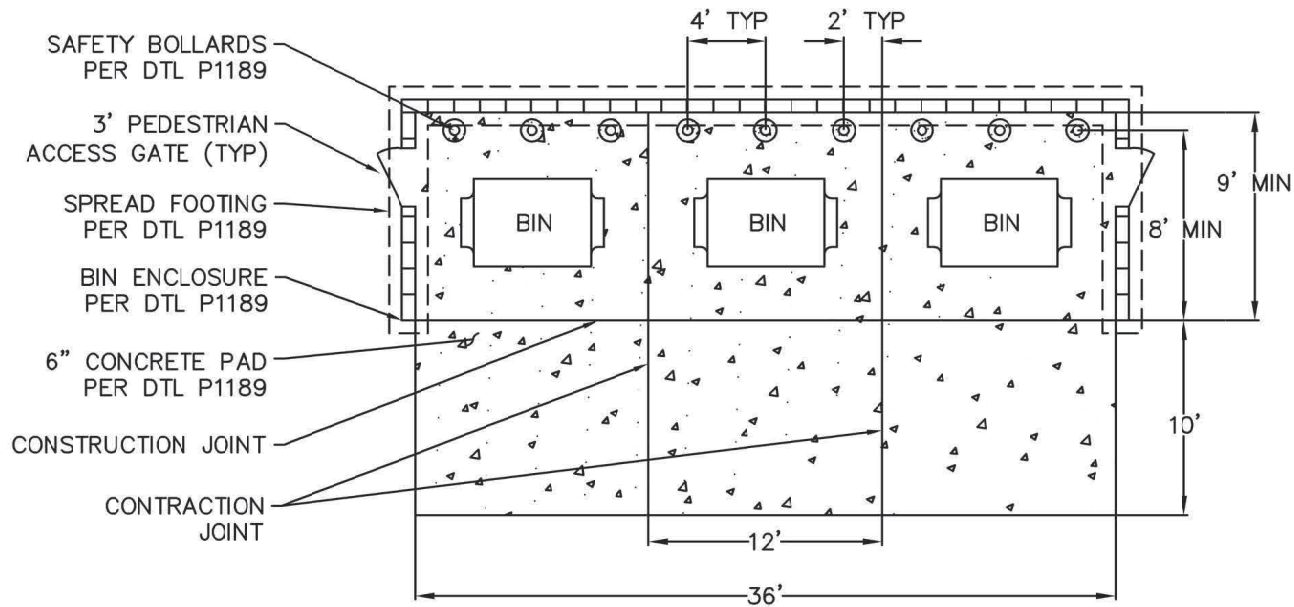
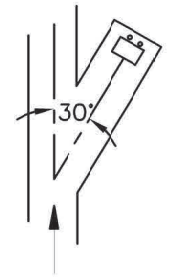

NTS

NOTES:

- 1) GATES, HINGES, AND MOUNTING HARDWARE SHALL NOT INTRUDE UPON MINIMUM NET ENCLOSURE OPENINGS.
- 2) BIN ENCLOSURES ARE TO BE ANGLED NO MORE THAN 30 DEGREES FROM THE CENTERLINE OF THE SOLID WASTE COLLECTION VEHICLE ROUTE.
- 3) CONTRACTION JOINTS MAY BE EITHER SCORED OR SAWCUT TO A DEPTH OF 1-INCH.
- 4) BINS THAT ARE VISIBLE FROM THE PUBLIC ROADWAY SHALL HAVE ENCLOSURE GATES THAT SCREEN THE BINS FROM PUBLIC VIEW PER DTL P1181.



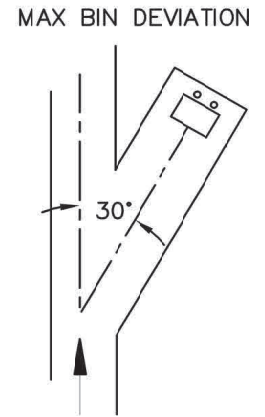
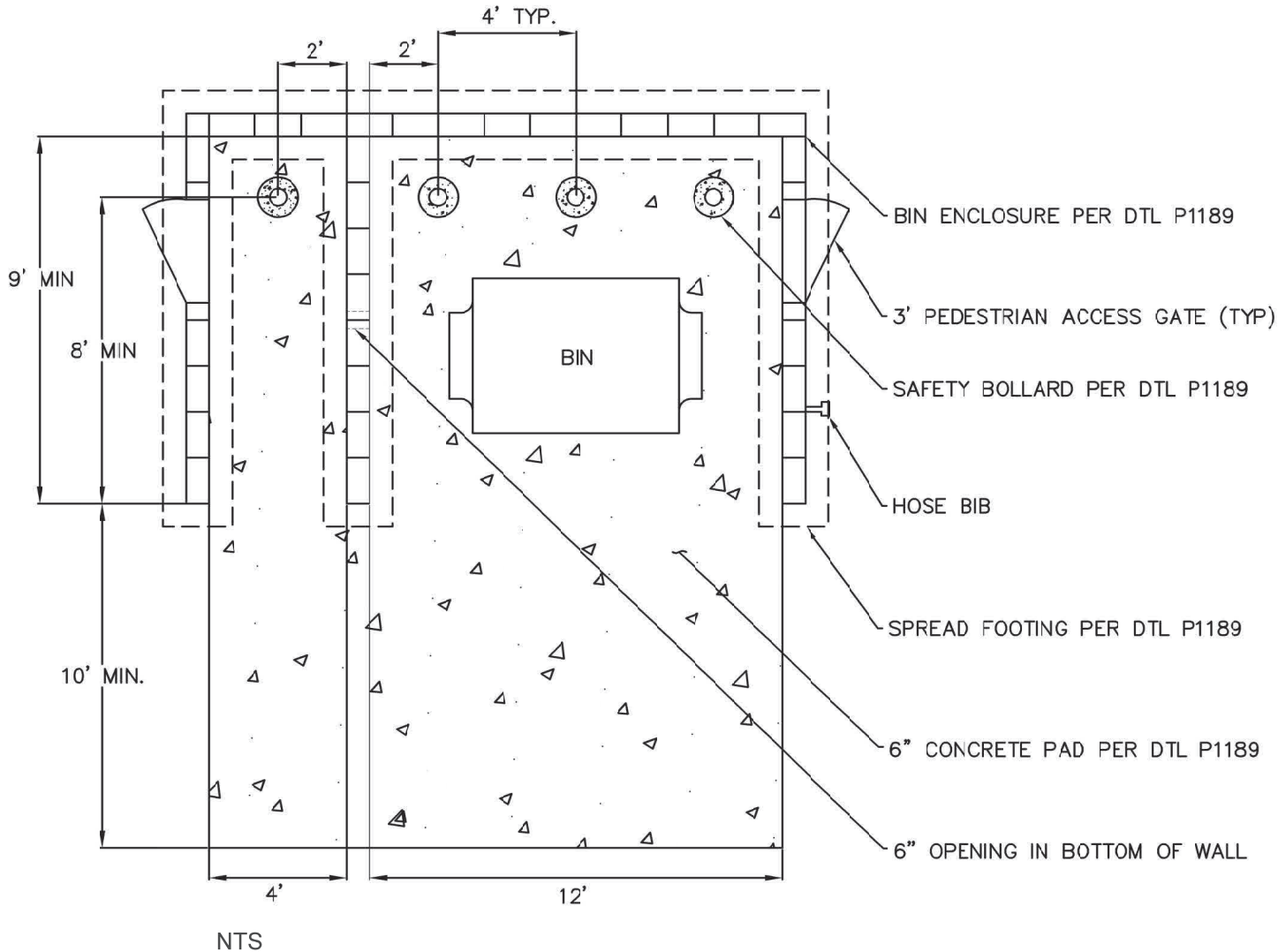

**NOTES**

- 1) WHERE CONNECTIONS TO THE SANITARY SEWER ARE PROVIDED, THE DRAINAGE SYSTEM SHALL BE CONNECTED TO A GREASE INTERCEPTOR.
- 2) BINS THAT ARE VISIBLE FROM THE PUBLIC ROADWAY SHALL HAVE ENCLOSURE GATES THAT SCREEN THE BINS FROM PUBLIC VIEW PER DTL P1181.





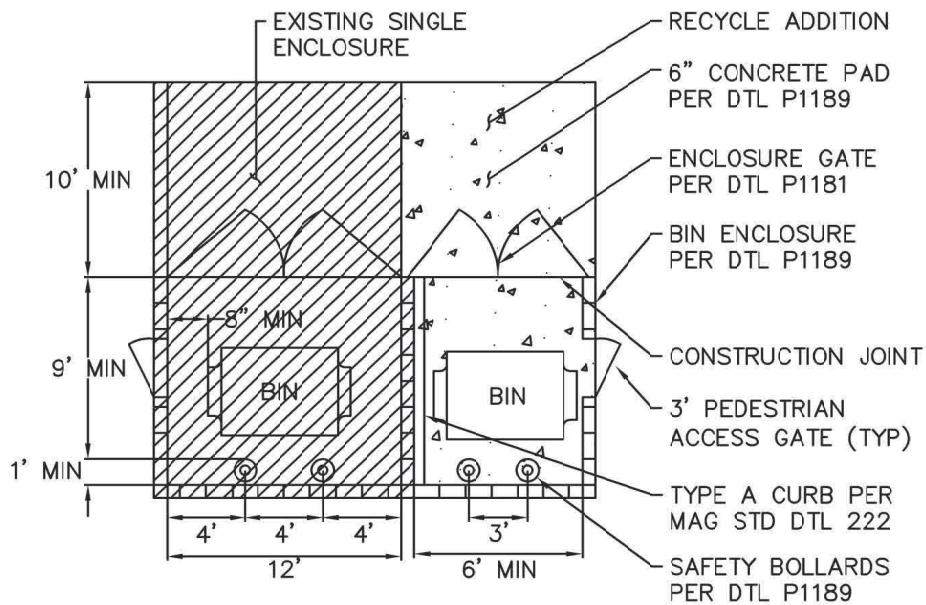

**NOTES**

- 1) 6'-WIDE COMPARTMENT TO ACCOMMODATE A 4-CY FRONT-LOAD BIN OR A 3-CY REAR-LOAD BIN.
- 2) THIS DESIGN CAN BE USED IN LIEU OF TWO SEPARATE STANDARD ENCLOSURES FOR A MAXIMUM 4-CY CAPACITY FOR RECYCLE.

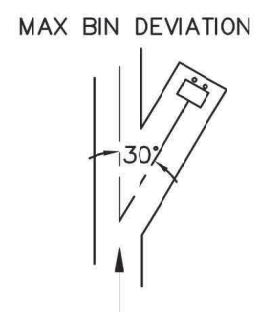

EXISTING ENCLOSURE WITH RECYCLE ADDITION

NTS

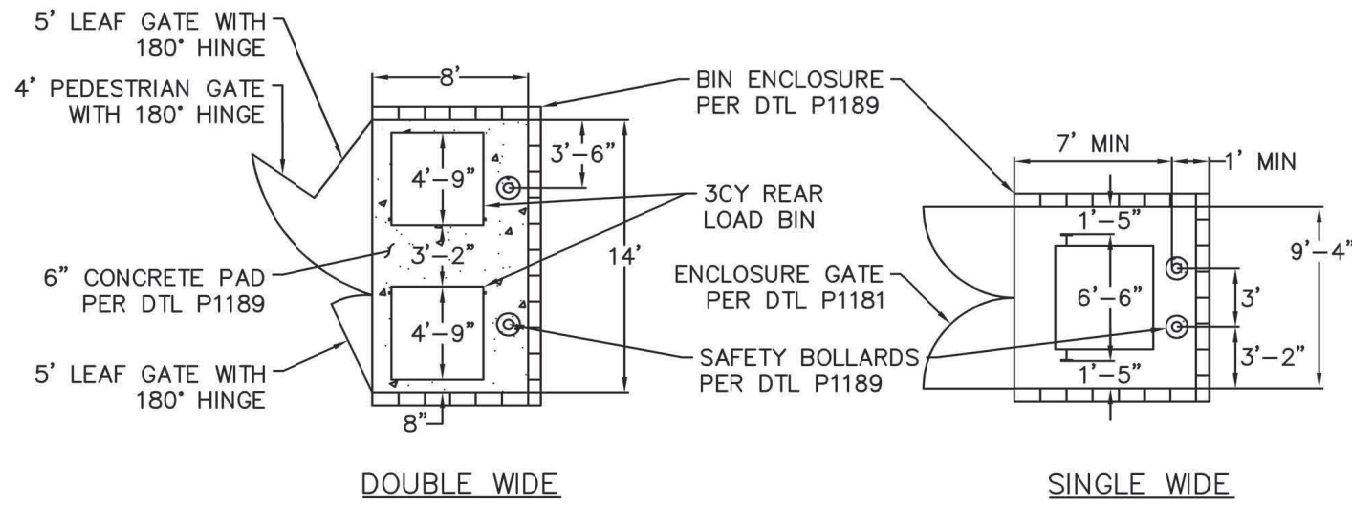

REAR-LOAD ENCLOSURES FOR INFILL AND LIMITED-ACCESS SITES

NTS

**NOTES**

- 1) THE CITY OF PHOENIX WILL APPROVE THE USE OF REAR-LOADING EQUIPMENT ON A CASE-BY-CASE BASIS FOR INFILL RESIDENTIAL DEVELOPMENTS AND RESIDENTIAL DEVELOPMENTS WITH LIMITED ACCESS.
- 2) A TURNAROUND TO ACCOMMODATE REAR-LOAD TRUCKS IS REQUIRED.
- 3) BINS WILL BE ROLLED FROM THE ENCLOSURE TO THE SOLID WASTE COLLECTION VEHICLE ACCESS ROUTE.
- 4) PROVIDE A MINIMUM 6' SIDEWALK WITH CURB RAMPS OR FLUSH TRANSITIONS TO SOLID WASTE COLLECTION VEHICLE ACCESS.
- 5) SLOPES WILL NOT EXCEED 1:20 EXCEPT AT CURB RAMPS.

**NOTES**

1. ENCLOSURE TO BE A MINIMUM OF 5 FEET FROM ANY PLANNED OR EXISTING STRUCTURE AT ITS CLOSEST POINT. REFER TO APPLICABLE FIRE CODE FOR MORE DETAILS.
2. BINS OR COMPACTORS THAT ARE VISIBLE FROM THE PUBLIC ROADWAY SHALL HAVE ENCLOSURE GATES THAT SCREEN FROM PUBLIC VIEW.
3. EACH ENCLOSURE GATE SHALL HAVE DROP PINS INSTALLED AND HOLES DRILLED IN THE CONCRETE AT BOTH THE OPEN AND CLOSED POSITIONS TO PREVENT THE GATES FROM STRIKING COLLECTION VEHICLES.
4. STEEL REINFORCEMENT SHALL BE GR60 AND SHALL HAVE 3" COVER.
5. USE CLASS "A" CONCRETE PER MAG SECTION 725.
6. EXTERIOR FINISH OF SCREEN WALLS SHALL BE COORDINATED ARCHITECTURALLY WITH PRIMARY BUILDING FINISHES.
7. SOIL BELOW THE WALL FOOTER AND CONCRETE PAD SHALL BE PREPARED IN ACCORDANCE WITH THE GEOTECHNICAL REPORT.
8. ADJUST FOOTING WIDTH TO 2' FOR WALL HEIGHTS LESS THAN OR EQUAL TO 6'.

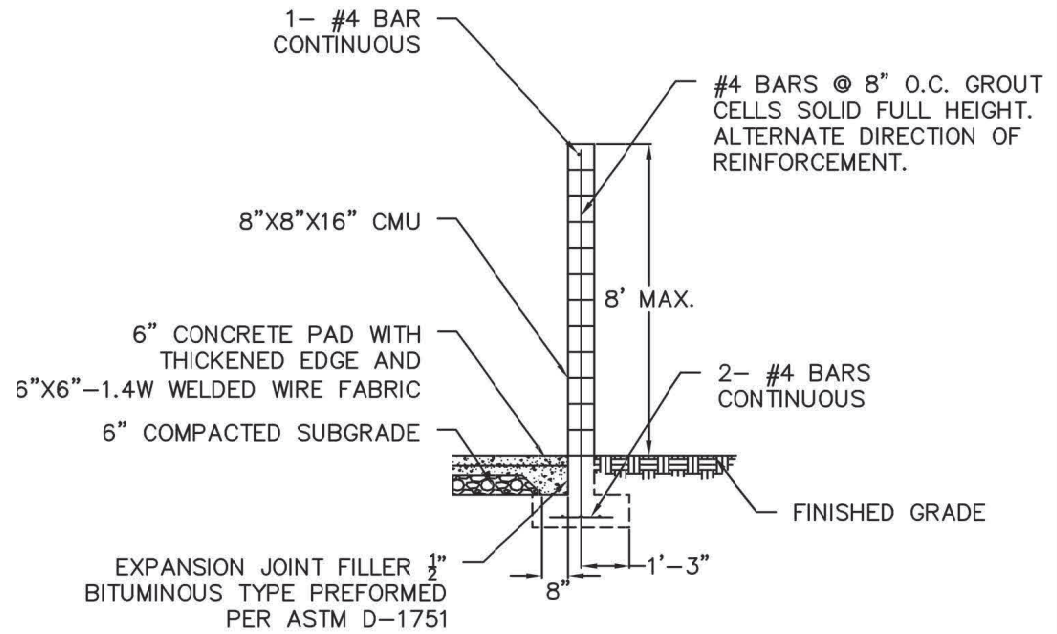

**(B) THICKENED EDGE SCREEN WALL**  
NTS

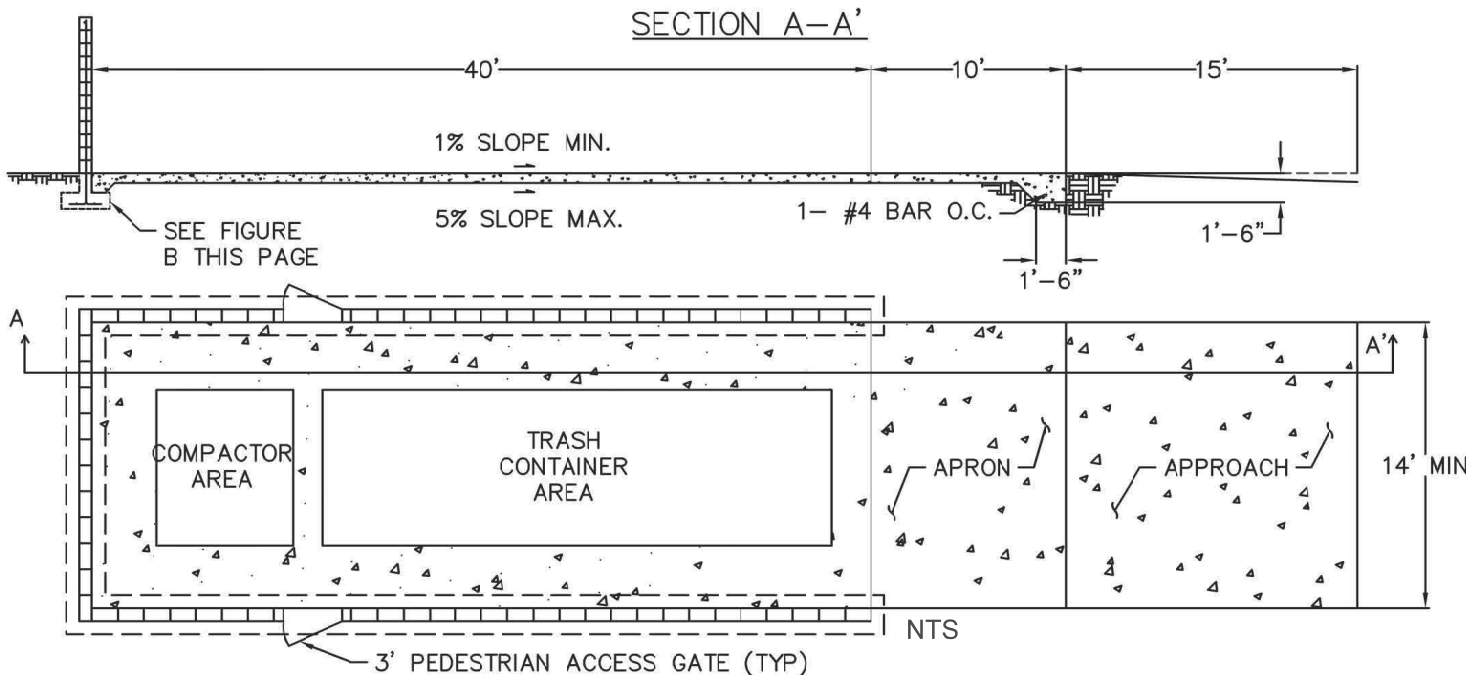

**NOTES**

1. WHERE COMPACTOR INSTALLATION PRODUCES LIQUID WASTE DRAINAGE, A RECEPTOR CONNECTED TO THE SANITARY SEWER SHALL BE PROVIDED AND THE DRAINAGE PIPING SHALL BE CONNECTED TO A GREASE INTERCEPTOR.
2. PROPER CLEANING METHODS SHALL BE USED TO PREVENT THE DISCHARGE OF WASH WATER INTO PUBLIC STORM DRAIN SYSTEM.
3. ENCLOSURES SHALL HAVE A MINIMUM NET OPENING OF 14 FEET.
4. SOME COMPACTORS MAY HAVE COMPACTOR AREA IN FRONT (PREFERRED METHOD). SELF-LOADING FRONT-LOAD COMPACTOR PREFERRED.



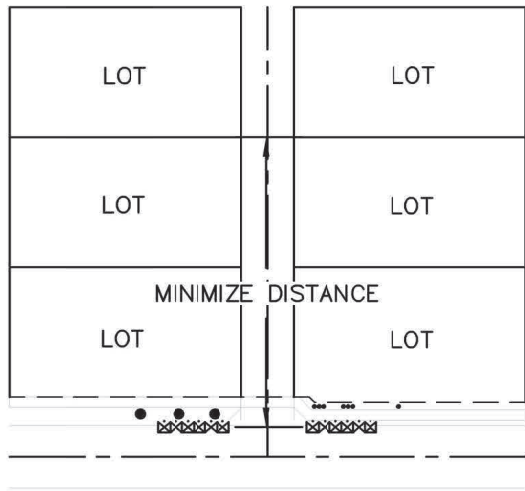

**NOTES:**

- 1) TWO BIN COLLECTION LOCATIONS PER RESIDENTIAL UNIT ARE REQUIRED. SPLIT BETWEEN THE ALLEY DRIVEWAY (E.G. 6 RESIDENTIAL HOMES WOULD REQUIRE 12 PADS).
- 2) LOCATION OF NO PARKING SIGN MAY NEED TO BE ADJUSTED TO ACCOUNT FOR ADJACENT FIRE HYDRANTS (15' PARKING RESTRICTIONS EACH SIDE), MAILBOXES, OR OTHER OBSTRUCTIONS.
- 3) BIN LOCATION AREA TO COMPLY WITH COP DETAIL P1188.
- 4) ON STREET PARKING REQUIREMENTS: <30' WIDTH: NO PARKING EITHER SIDE. 30' WIDTH: PARKING ON ONE SIDE EXCEPT IN FRONT OF BARREL PLACEMENT MARKERS, AS SIGNED. COORDINATE WITH SOLID WASTE AND STREETS TO DETERMINE WHICH SIDE OF THE STREET MAY HAVE PARKING. 34' WIDTH: NO PARKING IN FRONT OF BARREL PLACEMENT MARKERS, AS SIGNED.

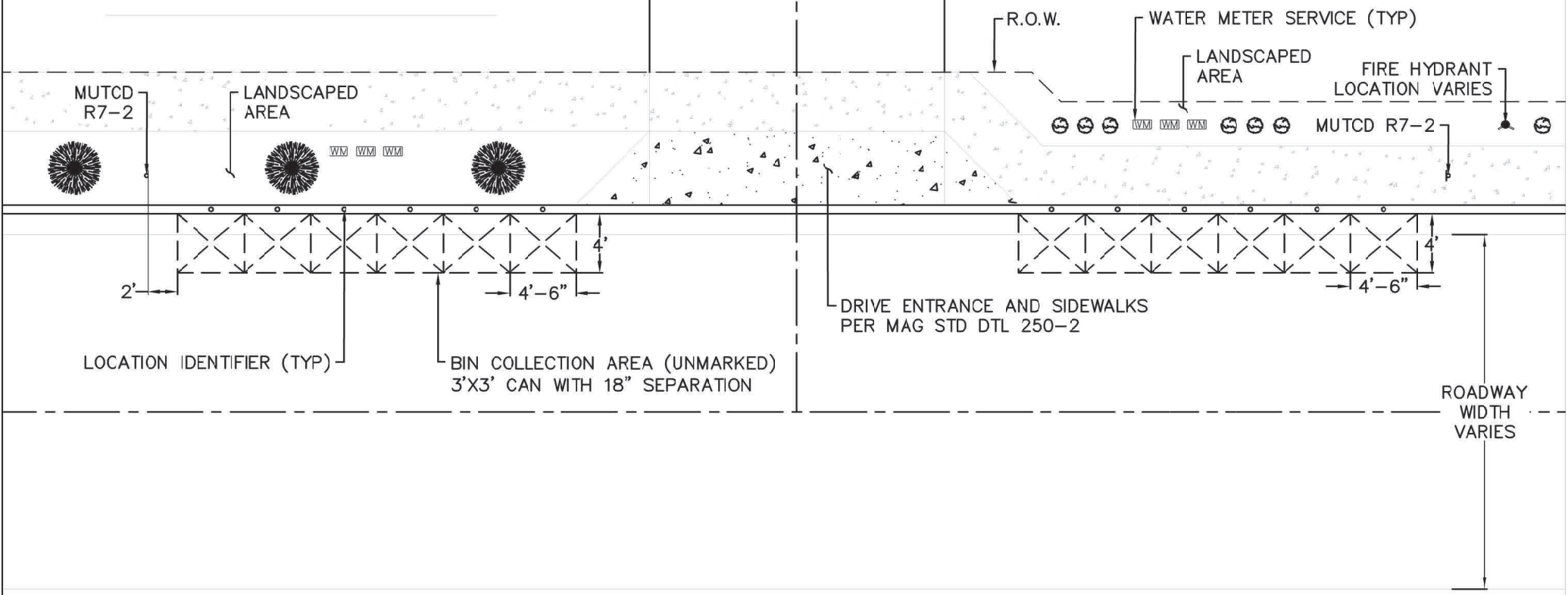

NTS

DETAIL NO.  
P1187



**City of Phoenix**  
STANDARD DETAIL

COLLECTION PADS FOR  
SMALL/MULTI LOT WITH PRIVATE DRIVES

*Eva...*  
CITY ENGINEER

04/01/2022  
DATE

DETAIL NO.  
P1187

SUBDIVISION REQUIREMENTS FOR AUTOMATED BIN COLLECTION

THE FOLLOWING LIST HAS BEEN DEVELOPED WITH REGARD TO ALL PLANS AND ZONING CHANGES TO ENSURE THAT THE SOLID WASTE DIVISION PROVIDES SAFE AND EFFICIENT RESIDENTIAL SOLID WASTE SERVICES TO OUR CUSTOMERS:

- 1) IF THE WIDTH OF THE PROPOSED PUBLIC STREET IS LESS THAN CITY REQUIREMENTS AND BIN COLLECTION IS ON ONE SIDE OF THE STREET ONLY, THEN YOU WILL NEED TO COMPLY WITH REQUIREMENTS 1,2,3,4 NOTED FOR SMALL LOT/MULTI-LOT WITH PRIVATE DRIVE BIN COLLECTION.
- 2) GATE OR DOOR OPENINGS MUST ALLOW FOR CONTAINER PASSAGE OF APPROXIMATELY 33 INCHES IN WIDTH.
- 3) PRIVATE STREETS MUST HAVE AN AREA FOR COLLECTION WITHOUT OBSTRUCTION.
- 4) PRIVATE STREETS MUST BE DESIGNED TO WITHSTAND THE WEIGHT OF 37-CY COLLECTION VEHICLES (APPROXIMATELY 29 TONS).
- 5) ALL STREETS MUST BE DESIGNED SO THAT COLLECTION VEHICLES ARE NOT FORCED TO BACK UP AT ANY TIME. HAMMERHEAD AND DEAD-ENDS ARE NOT ACCEPTABLE.
- 6) PRIVATE STREETS WITH CUL-DE-SACS MUST BE DESIGNED TO MEET CITY OF PHOENIX STANDARDS FOR CUL-DE-SAC TURNING RADII.
- 7) BINS SHALL BE SET OUT FOR COLLECTION BY 5:30 A.M. AND REMOVED NO LATER THAN 5:30 P.M. ON THE DAY OF COLLECTION.
- 8) DEVELOPERS OF GATED SUBDIVISIONS MUST SUPPLY SOLID WASTE COLLECTION SERVICES WITH A GATE CODE OR REMOTE ACCESS AT THE TIME OF INSTALLATION. FAILURE TO PROVIDE GATE CODE OR REMOTE ACCESS WILL RESULT IN THE INABILITY OF RECEIVING SERVICE. ALL GATES MUST OPEN FROM THE CODE OR REMOTE PROVIDED, WITH THE EXCEPTION OF EXIT-ONLY GATES, WHICH SHALL BE WIRED FOR AUTOMATIC OPENING. ALL GATES MUST REMAIN OPEN FOR A MINIMUM OF 30 SECONDS ONCE FULLY OPEN, OR UNTIL THE COLLECTION VEHICLE SAFELY PASSES THROUGH THE GATE.
- 9) STREETLIGHTS SHALL BE DESIGNED TO ACCOMMODATE THE HEIGHT OF THE SOLID WASTE COLLECTION VEHICLE.
- 10) MINIMUM 18' OVERHEAD CLEARANCE IS NEEDED FOR COLLECTION VEHICLE TO SAFELY NEGOTIATE.

SMALL LOT/MULTI-LOT WITH PRIVATE DRIVE BIN COLLECTION

THE COURTYARD OR CLUSTER TYPE HOME DESIGN THAT DOES NOT ALLOW FOR CURBSIDE PICKUP (IN FRONT OF A CUSTOMER'S HOME) OF THE SOLID WASTE AND RECYCLE BINS SHALL MEET THE FOLLOWING CRITERIA:

- 1) EACH UNIT MUST HAVE A PREDETERMINED LOCATION FOR A MINIMUM OF 2 BINS PER UNIT WHERE STREET PARKING IS PROHIBITED AT ALL TIMES. BINS SHALL HAVE A DESIGNATED LOCATION ON THE STREET WITH A PERMANENT MARKING ON THE CURB IDENTIFYING ADDRESS OR UNIT NUMBER.
- 2) THE COLLECTION POINTS SHALL BE DESIGNATED SO THAT THE RESIDENT FURTHEST FROM THE STREET HAS THE SHORTEST DISTANCE TO MOVE THEIR BIN. SEE DETAIL P1187.
- 3) NO STRUCTURE OF ANY KIND SHALL BE PLACED WITHIN 5' HORIZONTAL OF BIN COLLECTION LOCATION AREAS. REFER TO APPLICABLE FIRE CODE FOR MORE DETAILS.
- 4) THE REQUIRED USE OF IDENTIFIED LOCATIONS FOR INDIVIDUAL 90-GALLON CONTAINERS MUST BE INCLUDED IN THE HOMEOWNER'S CONDITIONS, COVENANT, AND RESTRICTIONS (CC&R).
- 5) BINS SHALL BE SET OUT FOR COLLECTION BY 5:30 A.M. AND REMOVED NO LATER THAN 5:30 P.M. ON THE DAY OF COLLECTION.
- 6) GARAGE OR STORAGE AREAS MUST HAVE ROOM TO ACCOMMODATE ONE 90-GALLON REFUSE CONTAINER AND ONE 90-GALLON RECYCLE CONTAINER.
- 7) GATE OR DOOR OPENINGS MUST ALLOW FOR CONTAINER PASSAGE OF APPROXIMATELY 33 INCHES IN WIDTH.
- 8) BIN COLLECTION LOCATION AREA SHALL NOT ENCROACH ONTO SIDEWALKS.



1. BIN ENCLOSURE TO BE A MINIMUM OF 5' FROM ANY PLANNED OR EXISTING STRUCTURE AT ITS CLOSEST POINT.
2. BINS THAT ARE VISIBLE FROM THE PUBLIC ROADWAY SHALL HAVE ENCLOSURE GATES THAT SCREEN THE BINS FROM PUBLIC VIEW PER DTL P1181.
3. GATES SHALL BE INSTALLED SO THERE IS A MINIMUM NET BIN ENCLOSURE OPENING OF 12' PER BIN, TO INCLUDE SPACE FOR GATES, HINGES, AND MOUNTING HARDWARE.
4. STEEL REINFORCEMENT SHALL BE GR60.
5. EACH ENCLOSURE GATE SHALL HAVE DROP PINS INSTALLED AND HOLES DRILLED IN THE CONCRETE AT BOTH THE OPEN AND CLOSED POSITIONS TO PREVENT GATES FROM CLOSING INTO THE COLLECTION VEHICLE.
6. BIN ENCLOSURES SHALL HAVE STEEL SAFETY POSTS INSTALLED AT THE BACK OF THE ENCLOSURE AS SHOWN PER SHEET. SEE FIGURE D THIS SHEET FOR DETAIL.
7. SAFETY POSTS/BOLLARDS SHALL HAVE A HEIGHT OF 6 FEET OR BE EQUAL TO THE HEIGHT OF THE BACK SCREEN WALL. SAFETY POSTS SHALL BE PLACED A MINIMUM OF 4" FROM THE WALL.
8. USE CLASS "A" CONCRETE PER MAG SECTION 725 EXCEPT AS NOTED.
9. GATES, HINGES, AND MOUNTING HARDWARE SHALL BE INSTALLED SO THERE IS A MINIMUM 9-FOOT DEPTH CREATED WITHIN EACH ENCLOSURE.
10. EXPANSION JOINT FILLER SHALL BE 1/2" BITUMINOUS TYPE PREFORMED EXPANSION JOINT FILLER PER ASTM D-1751.
11. EXTERIOR FINISH OF SCREEN WALLS SHALL BE COORDINATED ARCHITECTURALLY WITH PRIMARY BUILDING FINISHES.

12. SOIL BELOW THE WALL FOOTING AND CONCRETE PAD SHALL BE PREPARED IN ACCORDANCE WITH THE GEOTECHNICAL REPORT.

13. ADJUST FOOTING WIDTH TO 2' FOR WALL HEIGHTS LESS THAN OR EQUAL TO 6'.

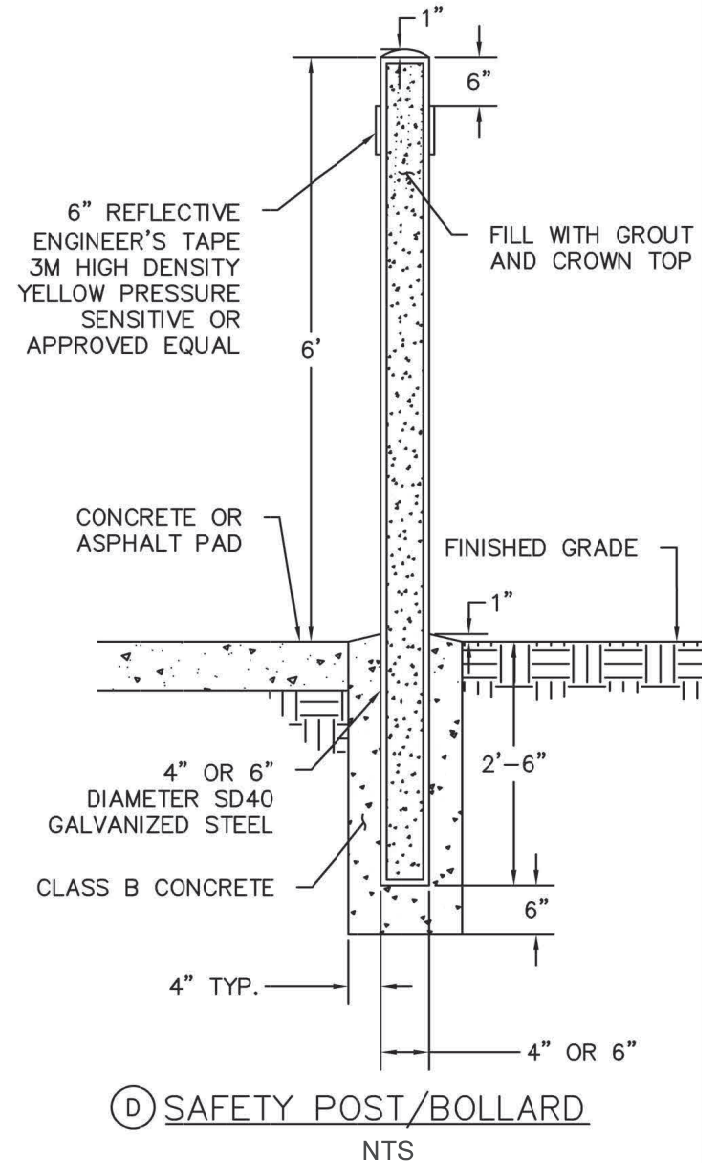
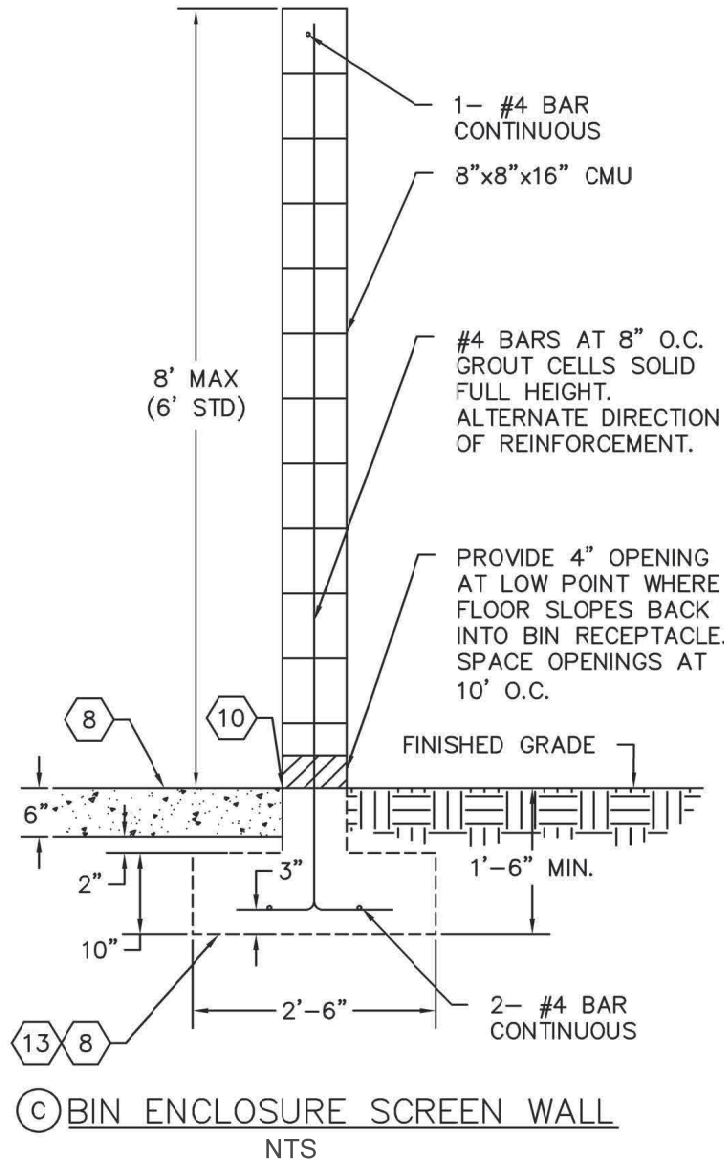

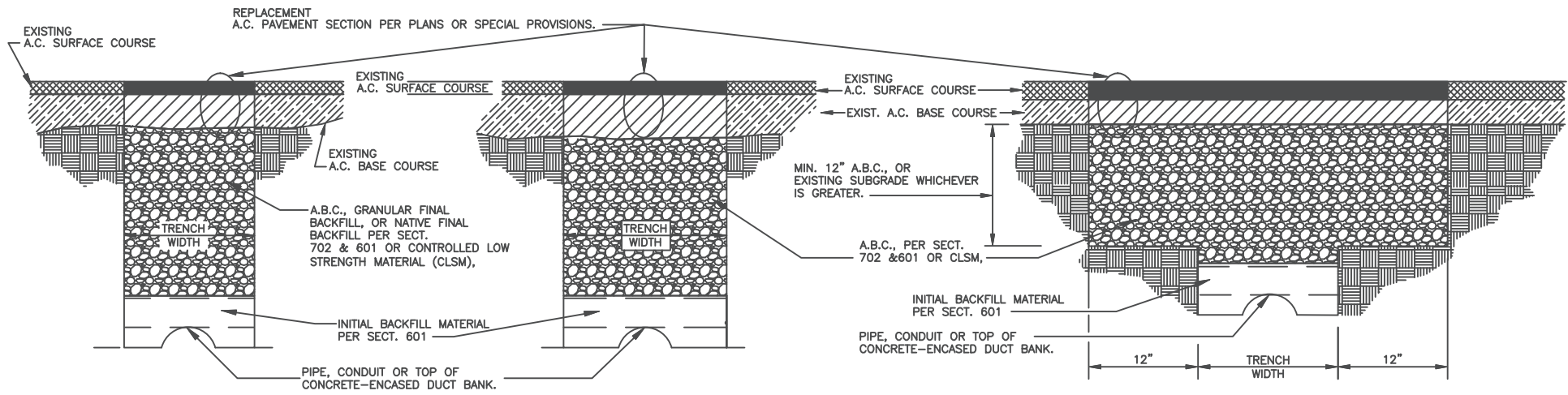

TYPE A

TYPE B

TYPE B-"T" TOP

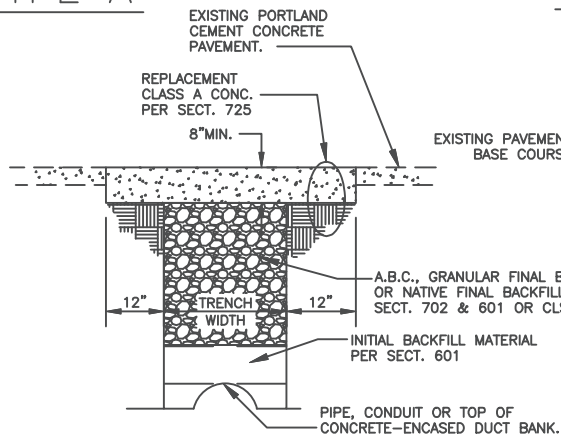

TYPE C

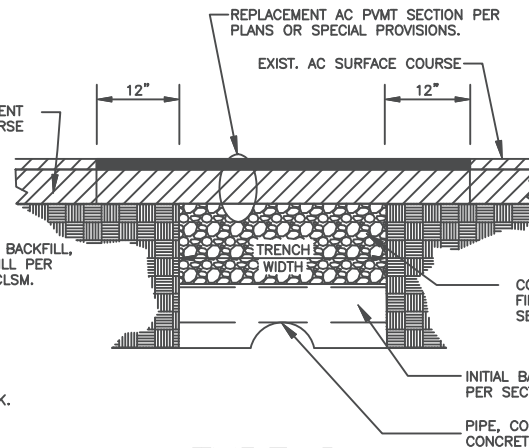

TYPE D

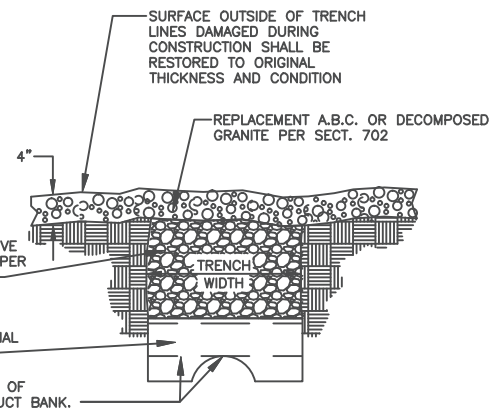

TYPE E

NOTES:

1. INITIAL BACKFILL PER SECTION 601 FOR ALL TRENCH TYPES.
2. REFER TO SECTION 336.3 FOR FINAL BACKFILL & SURFACE REPLACEMENT TYPES REQ'D BASED ON TRENCH ORIENTATION IN STREETS.
3. TRENCH WIDTH PER SECTION 336 & 601.
4. EXPOSED WATER SERVICE PIPES THAT CROSS TRENCHES TO BE BACKFILLED WITH CLSM SHALL BE WRAPPED WITH MIN. 3/4" THICK CLOSED CELL FOAM INSULATION PRIOR TO PLACEMENT OF CLSM.
5. FOR TRENCHES UP TO 24" WIDE, CLSM MAY BE USED UP TO THE REPLACEMENT PAVEMENT SUBGRADE LEVEL. FOR TRENCHES BETWEEN 24" AND 6' WIDE, CLSM SHALL ONLY BE PLACED IN THE TOP 24" OF TRENCH. FOR TRENCHES WIDER THAN 6', CLSM FINAL BACKFILL SHALL NOT BE USED, UNLESS APPROVED BY THE ENGINEER.

DETAIL NO.  
P1200



**City of Phoenix**  
**STANDARD DETAIL**

TRENCH BACKFILL  
& SURFACE REPLACEMENT

APPROVED

*[Signature]*  
CITY ENGINEER

07/01/2015  
DATE

DETAIL NO.  
P1200

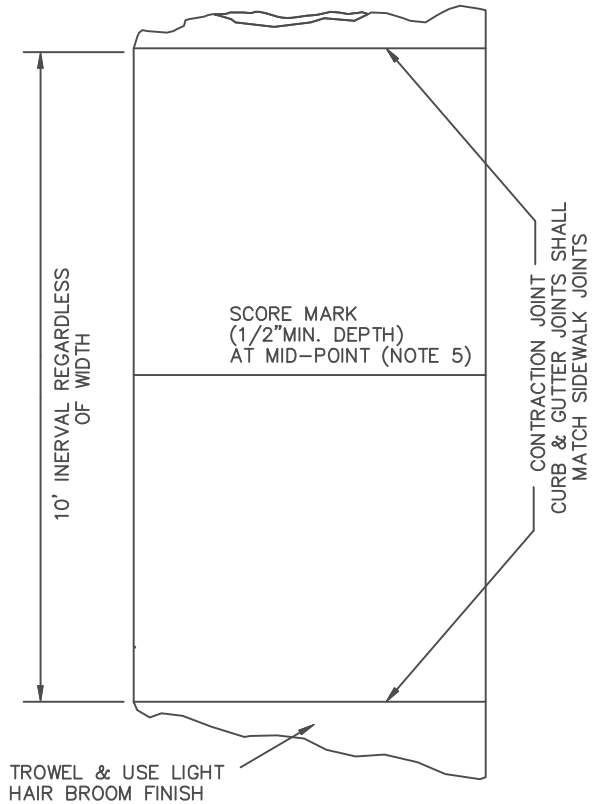
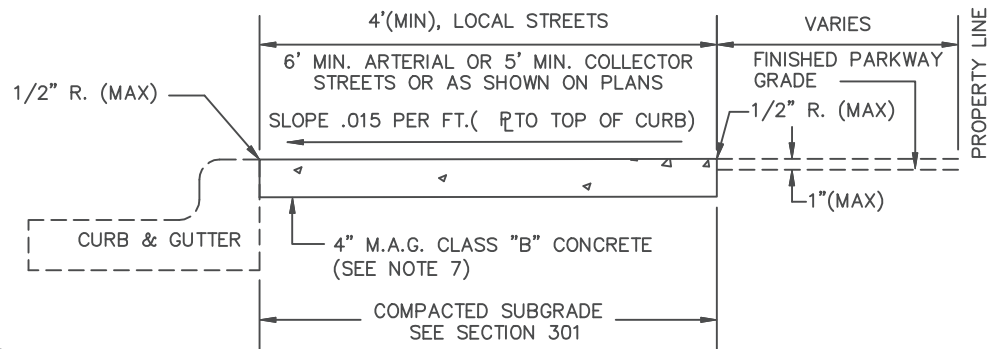

**NOTES:**

1. SIDEWALK CONSTRUCTION SHALL CONFORM TO SECTION 340.
2. EXPANSION JOINT FILLER SHALL BE 1/2" BITUMINOUS TYPE PREFORMED EXPANSION JOINT FILLER, A.S.T.M. D-1751.
3. EXPANSION JOINTS SHALL BE INSTALLED PRIOR TO ALL POURS, AT POINTS OF CURVATURE, AT ADJOINING STRUCTURES, AT DRIVEWAYS AND AT A MAXIMUM SPACING OF 50'. THE EXPANSION JOINT MUST PROVIDE FOR COMPLETE SEPARATION OF THE SIDEWALK FROM ADJOINING CONCRETE.
4. THE EXPANSION JOINT MATERIAL SHALL EXTEND FROM 1/4" BELOW THE TOP SURFACE OF THE SIDEWALK TO 1" INTO THE SUBGRADE.
5. WHEN SIDEWALK AND ADJACENT CURB ARE INSTALLED MONOLITHICALLY, THE MID-POINT SCORE LINE MUST EXTEND ACROSS THE CURB & GUTTER.
6. EXCEPTION TO BE APPROVED BY CITY ENGINEER.
7. CONCRETE SHALL BE M.A.G. CLASS "A" IN AREAS WITH CROSSING VEHICULAR TRAFFIC.

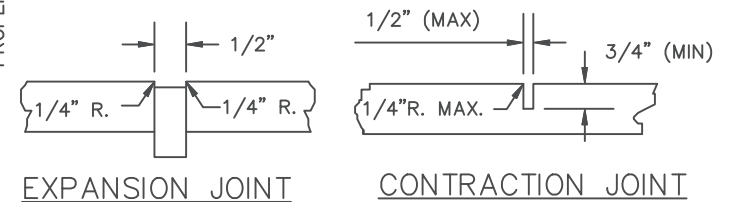
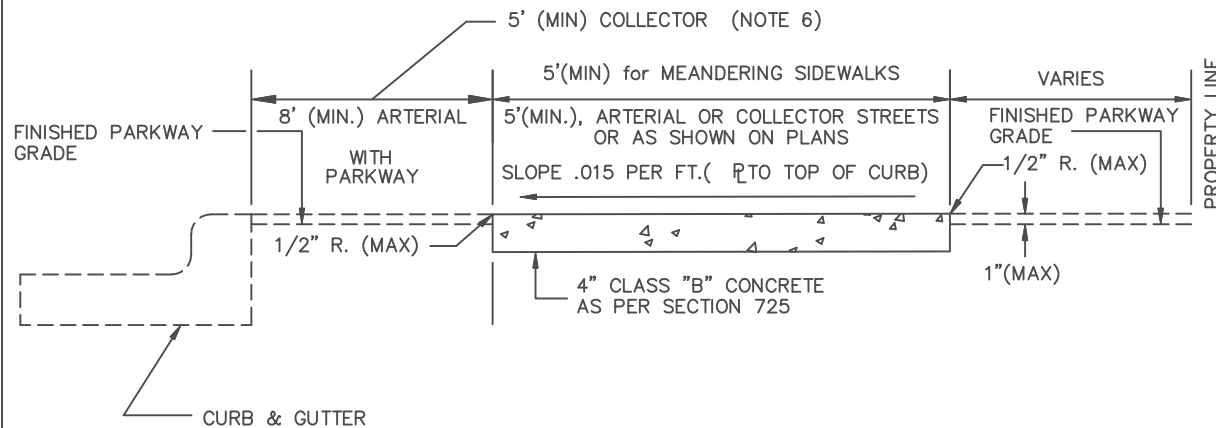

DETAIL NO.  
P1230



**City of Phoenix**  
**STANDARD DETAIL**

SIDEWALKS

APPROVED

*[Signature]*  
CITY ENGINEER

07/01/2015  
DATE

DETAIL NO.  
P1230

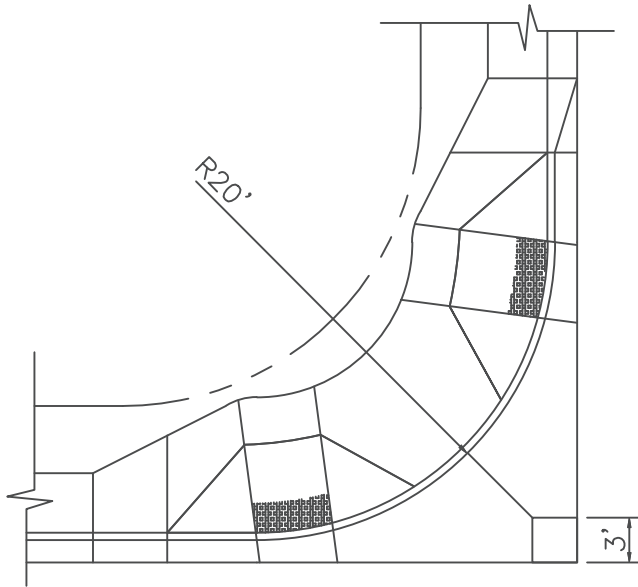
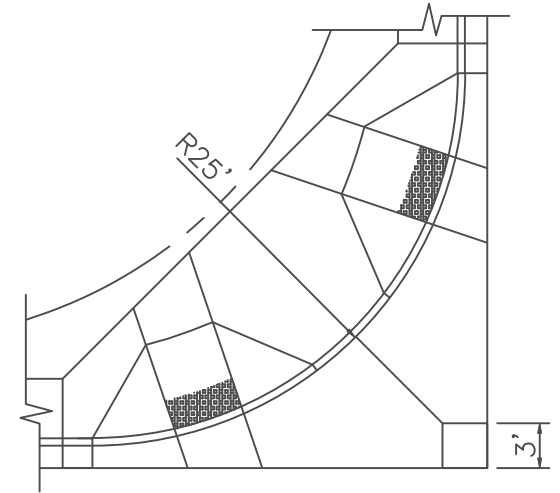
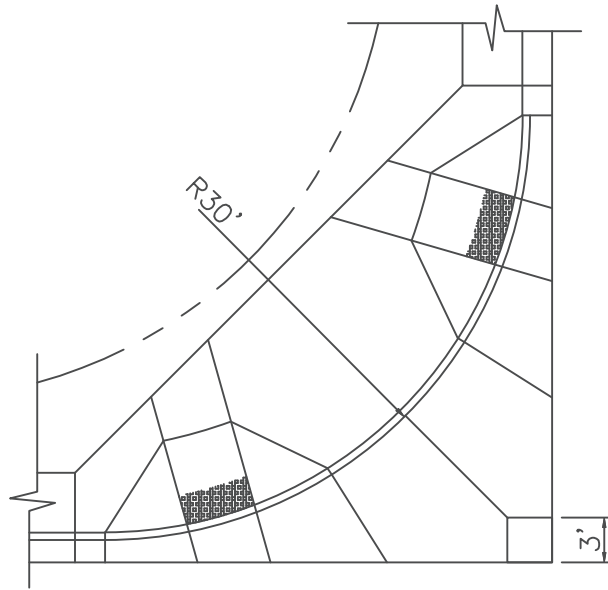
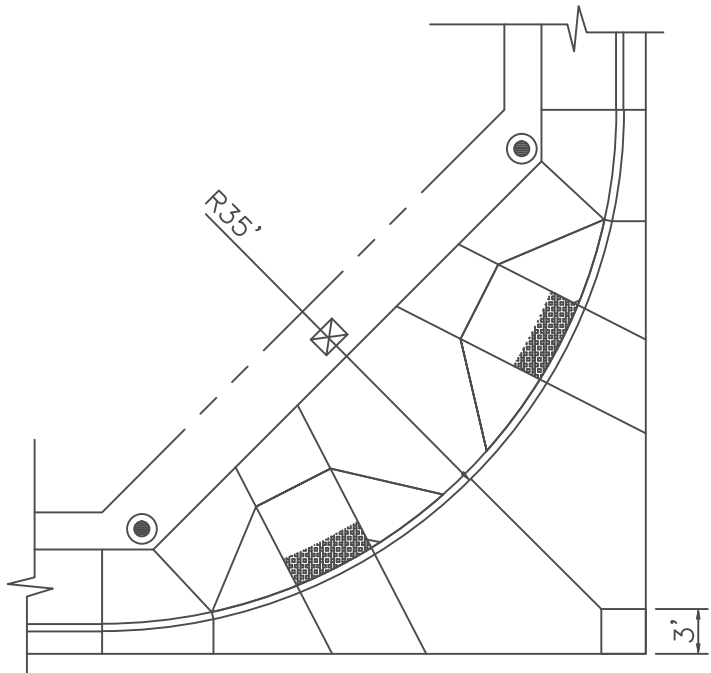

NOTES:

1. CONSTRUCT THE CONTRACTION JOINTS AS SHOWN ON CONCRETE APRON FOR THE RADIUS REQUIRED.
2. WHEN PLANS CALL FOR A CLASS "A" CONCRETE VALLEY GUTTER THE CONTRACTION JOINTS SHALL BE SPACED SYMMETRICAL WITH AT LEAST ONE JOINT EVERY 10 FEET.
3. WHEN PLANS CALL FOR A 7' VALLEY GUTTER, MAKE A 7' SQUARE INSTEAD OF A 3' SQUARE.

DETAIL NO.  
P1231



**City of Phoenix**  
**STANDARD DETAIL**

APRON JOINTS

APPROVED

*[Signature]*  
CITY ENGINEER

07/01/2015  
DATE

DETAIL NO.  
P1231



**NOTES:**

1. CONSTRUCTION DETAILS FOR ALL SIDEWALK RAMP ARE PRESENTED IN DETAILS P1233 THROUGH P1241-4.
2. DETECTABLE WARNING STRIP:
  - 2.1 SHALL BE OF CONCRETE, CONCRETE POLYMER OR APPROVED EQUIVALENT.
  - 2.2 SHALL HAVE A 5/8" MINIMUM THICKNESS.
  - 2.3 SHALL BE 8000 PSI MINIMUM RATED.
  - 2.4 SHALL NOT BE CONSTRUCTED OF ASPHALT PAVEMENT, BRICK PAVERS, STAMPED CONCRETE, OR ANY TYPE OF GLUE-DOWN MATERIAL.
  - 2.5 DOME AREA SHALL BE OF A CONTRASTING COLOR FROM THE SURROUNDING WALKING AREAS. FOR EXAMPLE, DARK ON LIGHT OR LIGHT ON DARK (MINIMUM OF 70% CONTRAST).

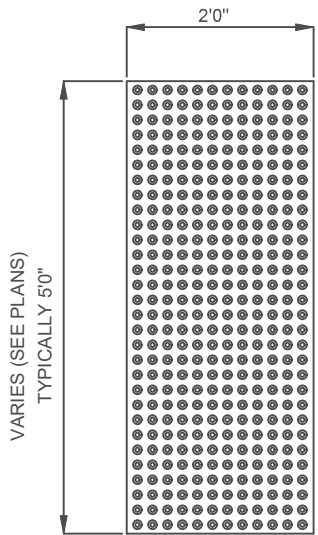
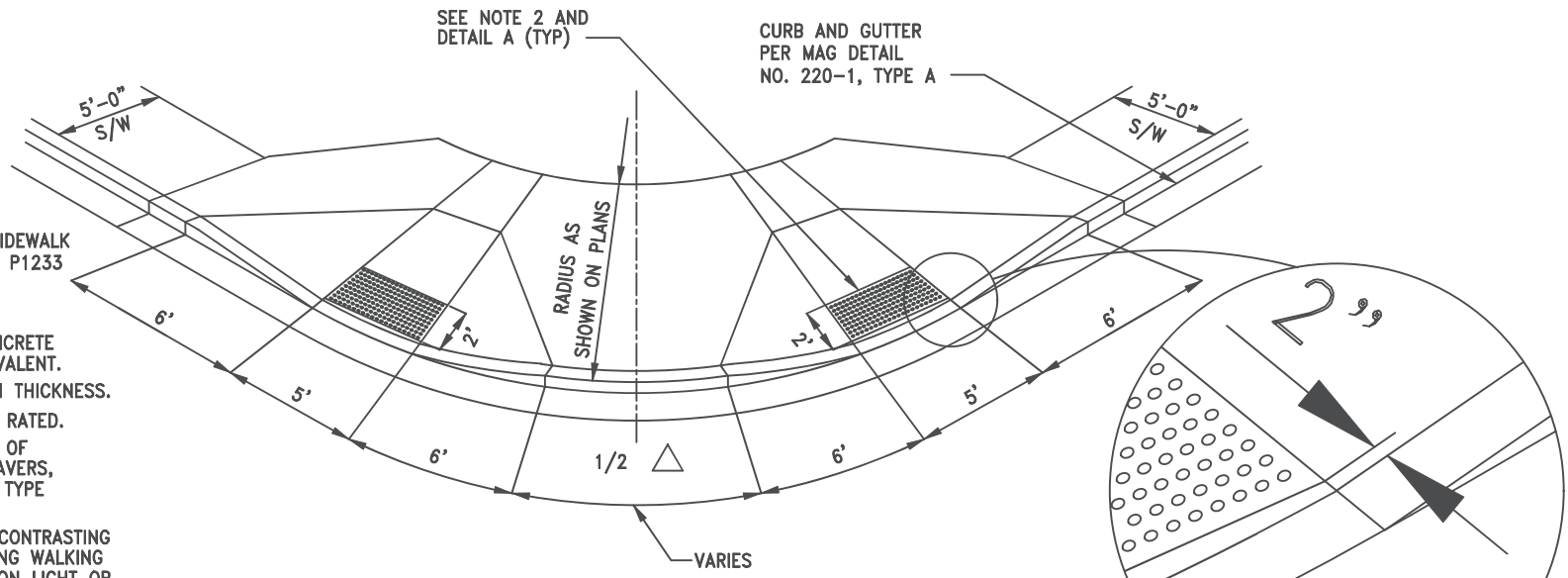

**DETECTABLE WARNING STRIP**

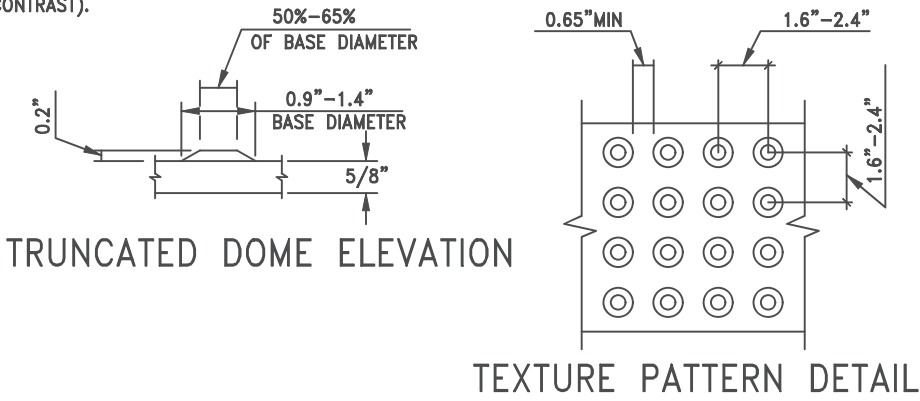

**TRUNCATED DOME ELEVATION**

**TEXTURE PATTERN DETAIL**

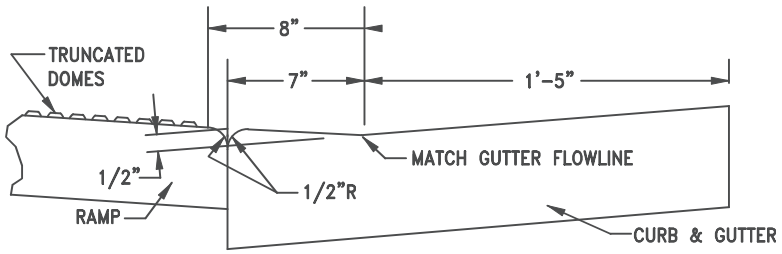

**DETAIL A (NTS)**

ICC / ANSI A117.1-2003  
705.5 TRUNCATED DOMES

DETECTABLE WARNING SURFACES SHALL HAVE TRUNCATED DOMES COMPLYING WITH SECTION 705.5 OF THE ICC/ANSI A117.1-2003, PROVIDED BELOW.

705.5.1 SIZE. TRUNCATED DOMES SHALL HAVE A BASE DIAMETER OF 0.9 INCH (23mm) MINIMUM TO 1.4 INCH (36mm) MAXIMUM, AND A TOP DIAMETER OF 50 PERCENT MINIMUM TO 65 PERCENT MAXIMUM OF THE BASE DIAMETER.

705.5.2 HEIGHT. TRUNCATED DOMES SHALL HAVE A HEIGHT OF 0.2 INCH (5.1mm).

705.5.3 SPACING. TRUNCATED DOMES SHALL HAVE A CENTER-TO-CENTER SPACING OF 1.6 INCHES (41mm) MINIMUM TO 2.4 INCHES (61mm) MAXIMUM, AND A BASE-TO-BASE SPACING OF 0.65 INCH (16.5mm) MINIMUM, MEASURED BETWEEN THE MOST ADJACENT DOMES ON THE GRID.

705.5.4 ALIGNMENT. TRUNCATED DOMES SHALL BE ALIGNED IN A SQUARE GRID PATTERN.

DIMENSION TABLE	
A(ft)	C(ft)
20	5-10
25	15
30	20
35	25

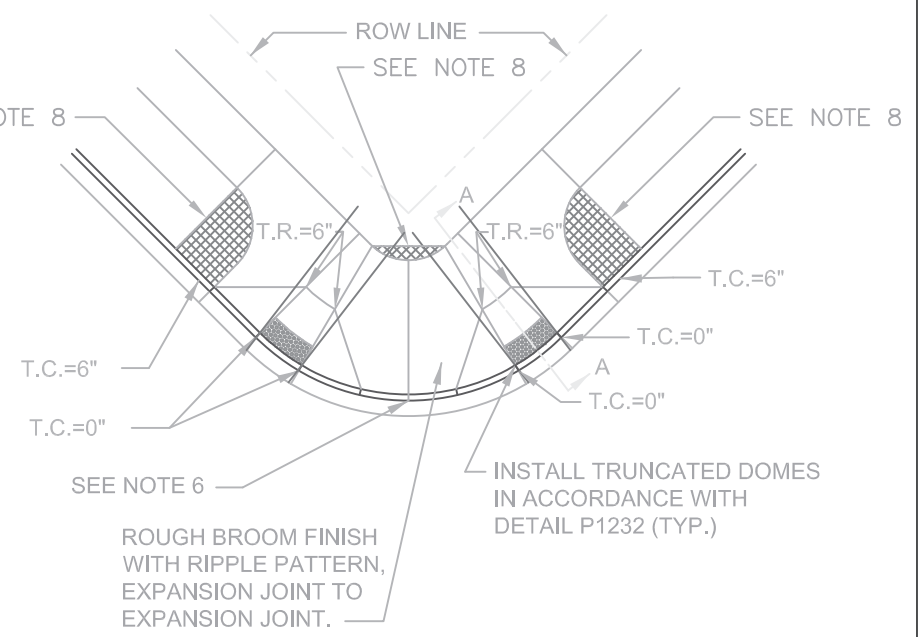
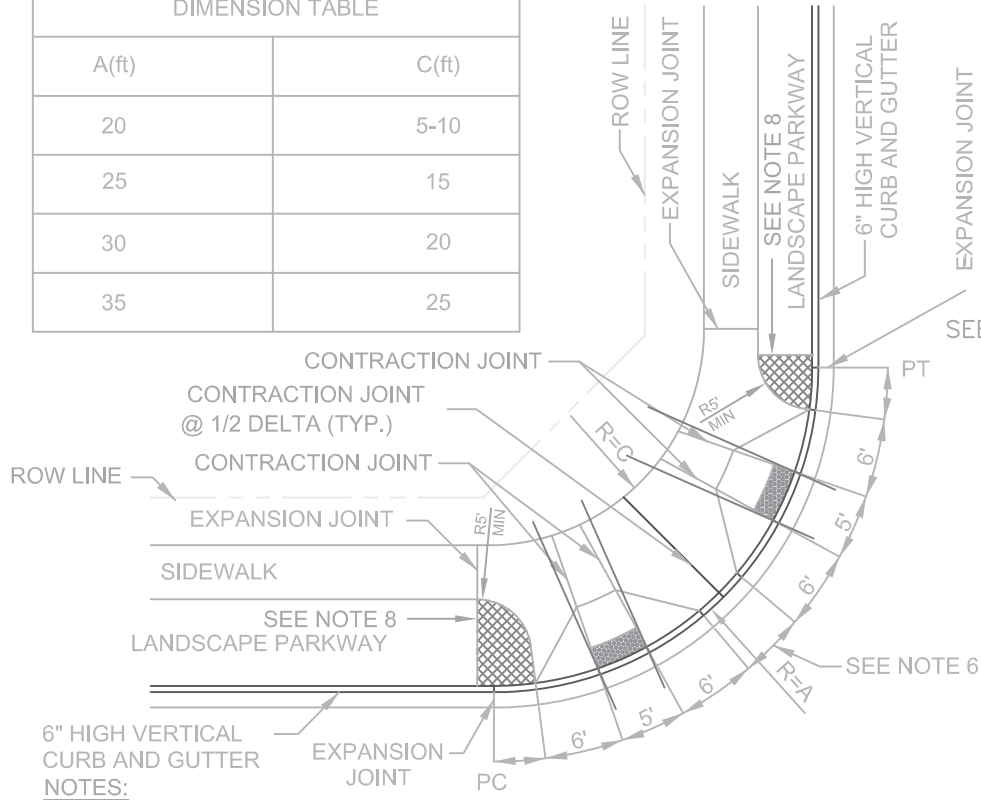

- NOTES:
- CONTROL ELEVATIONS ARE SHOWN IN RELATION TO THE GUTTER AND ARE LOCATED RADIALLY. GUTTER ELEVATION=0".
  - CONCRETE CURB AND GUTTER AT CURB RETURNS WITH RAMPS SHALL BE M.A.G. CLASS A. CONCRETE SIDEWALKS AND RAMPS AT CURB RETURNS SHALL BE M.A.G. CLASS A.
  - RAMP CURBS MAY BE POURED MONOLITHIC WITH A CONTRACTION JOINT.
  - EXPANSION JOINT FILLER SHALL BE 1/2" BITUMINOUS TYPE PREFORMED EXPANSION JOINT FILLER A.S.T.M. D-1751
  - 9" THICK LANDING, RAMPS, AND CURBS FROM EXPANSION JOINT TO EXPANSION JOINT ON MAJOR OR COLLECTOR STREETS. 4" THICK LANDING AND RAMPS ON LOCAL STREETS.
  - REDUCE CURB HEIGHT BY 1" MAXIMUM IN ORDER TO ACCOMMODATE A 12" SEPARATION BETWEEN RAMPS.
  - MAINTAIN THE PLANE OF THE LANDING ONE FOOT (1ft.) BEYOND THE TOP OF LANDING.
  - ADDITIONAL SIDEWALK PER NOTE 2 & 5 WHEN SIGNAL POLES ARE LOCATED IN THESE AREAS.
  - DETAIL PROVIDED FOR GENERAL GUIDANCE. RAMP ELEVATIONS, SLOPES, AND DISTANCES TO BE PROVIDED ON SEALED CONSTRUCTION DOCUMENTS.

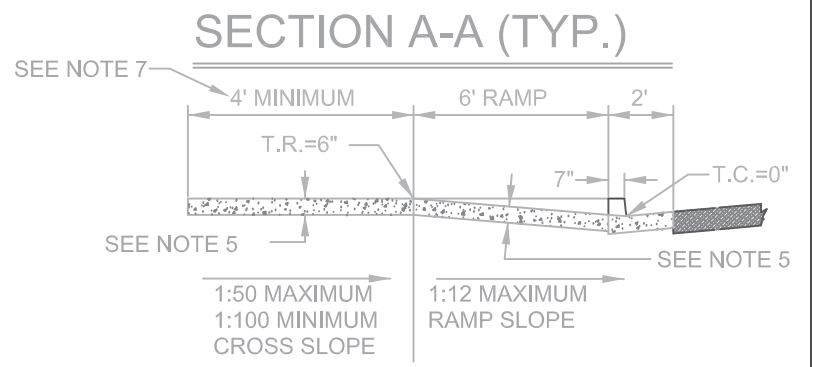

DIMENSION TABLE	
A(ft)	B(ft)
20	*
25	*
30	20
35	24

\* RAMP IS STRAIGHT ACROSS THE BACK.

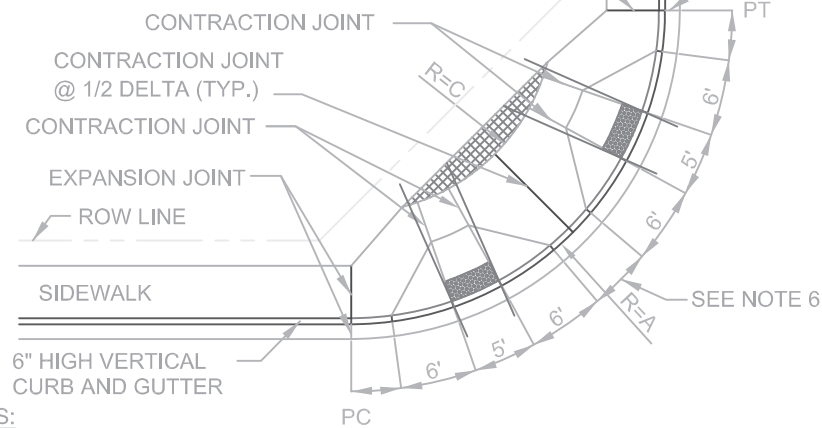

NOTES:

- CONTROL ELEVATIONS ARE SHOWN IN RELATION TO THE GUTTER AND ARE LOCATED RADIALY. GUTTER ELEVATION=0".
- CONCRETE CURB AND GUTTER AT CURB RETURNS WITH RAMPS SHALL BE M.A.G. CLASS A. CONCRETE SIDEWALKS AND RAMPS AT CURB RETURNS SHALL BE M.A.G. CLASS A.
- RAMP CURBS MAY BE POURED MONOLITHIC WITH A CONTRACTION JOINT.
- EXPANSION JOINT FILLER SHALL BE 1/2" BITUMINOUS TYPE PREFORMED EXPANSION JOINT FILLER A.S.T.M. D-1751
- 9" THICK LANDING, RAMPS, AND CURBS FROM EXPANSION JOINT TO EXPANSION JOINT ON MAJOR OR COLLECTOR STREETS. 4" THICK LANDING AND RAMPS ON LOCAL STREETS.
- REDUCE CURB HEIGHT BY 1" MAXIMUM IN ORDER TO ACCOMMODATE A 12" SEPARATION BETWEEN RAMPS.
- MAINTAIN THE PLANE OF THE LANDING ONE FOOT (1ft.) BEYOND THE TOP OF LANDING.
- ADDITIONAL SIDEWALK PER NOTE 2 & 5 WHEN SIGNAL POLES ARE LOCATED IN THESE AREAS.
- DETAIL PROVIDED FOR GENERAL GUIDANCE. RAMP ELEVATIONS, SLOPES, AND DISTANCES TO BE PROVIDED ON SEALED CONSTRUCTION DOCUMENTS.

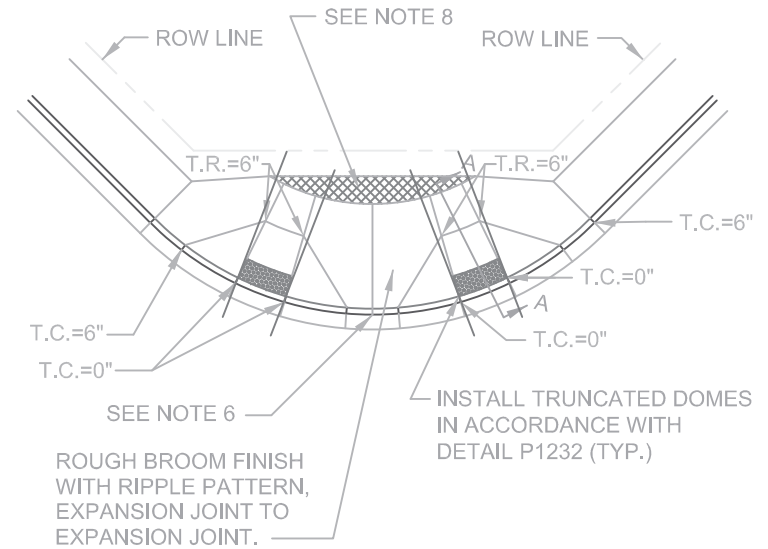

SECTION A-A (TYP.)

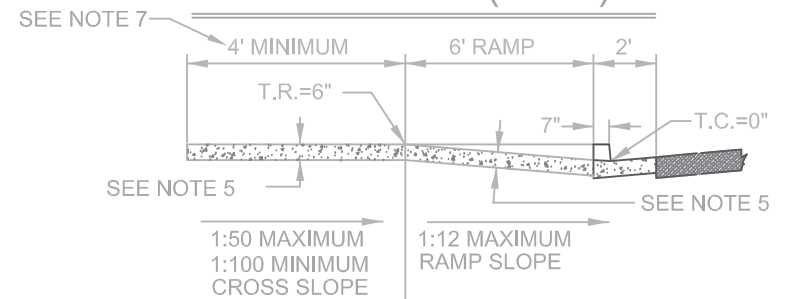

DETAIL NO.  
P1236



City of Phoenix  
STANDARD DETAIL

CURB RAMP DETAIL  
NO LANDSCAPE PLANTERS

APPROVED

*Eva Flores*  
CITY ENGINEER

04/01/2022  
DATE

DETAIL NO.  
P1236

RADII TABLE	
A(ft)	B(ft)
20	12
25	17
30	22.5

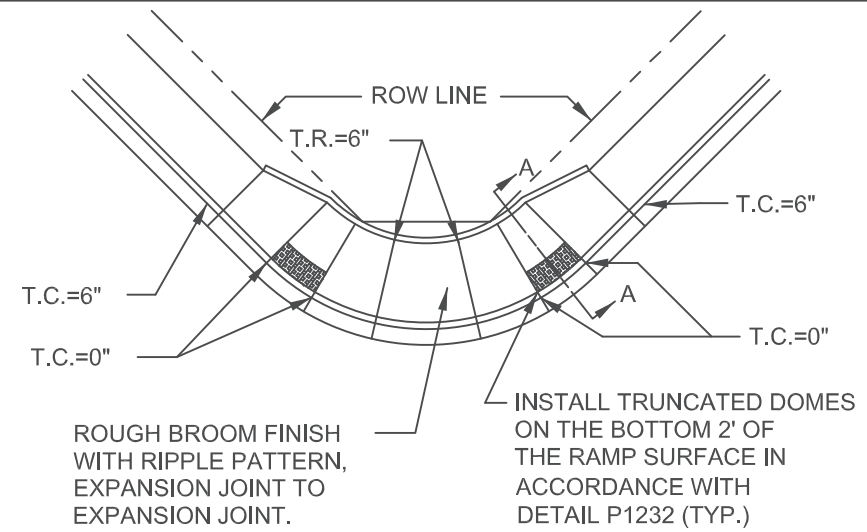
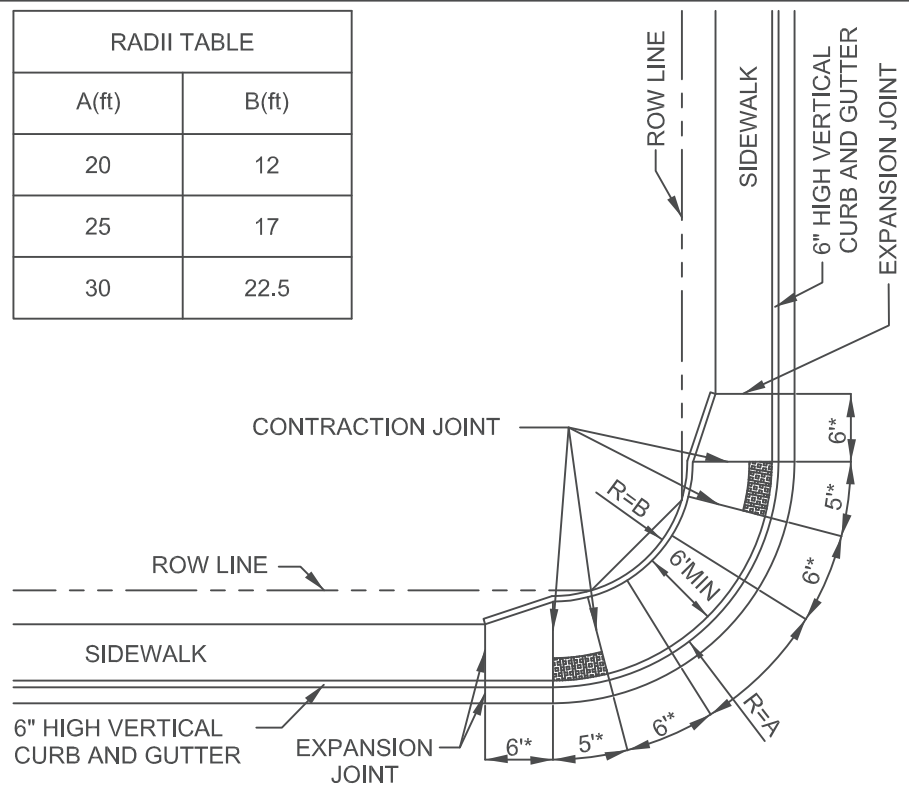

### SECTION A-A (TYP.)

- NOTES:
- 1. CONTROL ELEVATIONS ARE SHOWN IN RELATION TO THE GUTTER AND ARE LOCATED RADIALLY. GUTTER ELEVATION=0".
  - 2. CONCRETE CURB AND GUTTER AT CURB RETURNS WITH RAMPS SHALL BE M.A.G. CLASS A. CONCRETE SIDEWALKS AND RAMPS AT CURB RETURNS SHALL BE M.A.G. CLASS A.
  - 3. RAMP CURBS MAY BE POURED MONOLITHIC WITH A CONTRACTION JOINT.
  - 4. EXPANSION JOINT FILLER SHALL BE 1/2" BITUMINOUS TYPE PREFORMED EXPANSION JOINT FILLER A.S.T.M. D-1751
  - 5. 9" THICK LANDING, RAMPS, AND CURBS FROM EXPANSION JOINT TO EXPANSION JOINT ON MAJOR OR COLLECTOR STREETS. 4" THICK LANDING AND RAMPS ON LOCAL STREETS.
  - 6. 9" CURB ON MAJOR AND COLLECTOR STREETS AND 6" CURB ON LOCAL STREETS.
  - 7. DETAIL PROVIDED FOR GENERAL GUIDANCE. RAMP ELEVATIONS, SLOPES, AND DISTANCES TO BE PROVIDED ON SEALED CONSTRUCTION DOCUMENTS.
- \* MINIMUM WIDTH

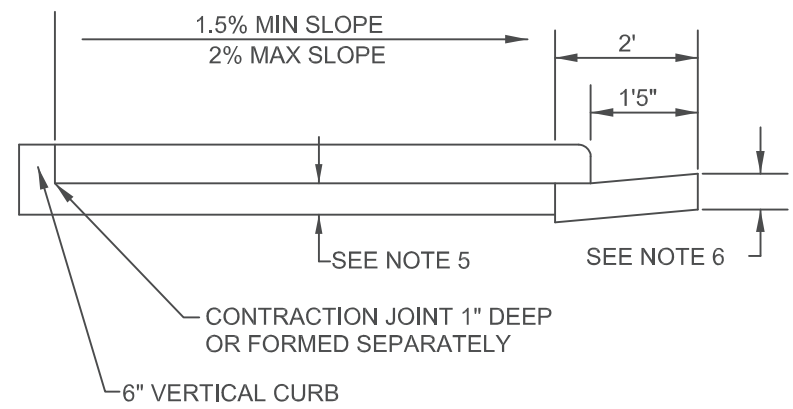

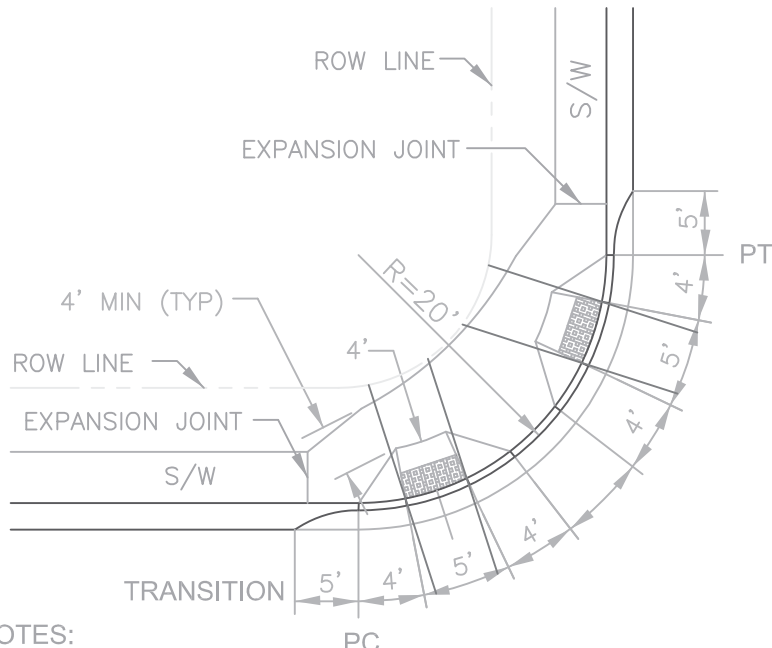

ROUGH BROOM FINISH WITH RIPPLE PATTERN, EXPANSION JOINT TO EXPANSION JOINT.

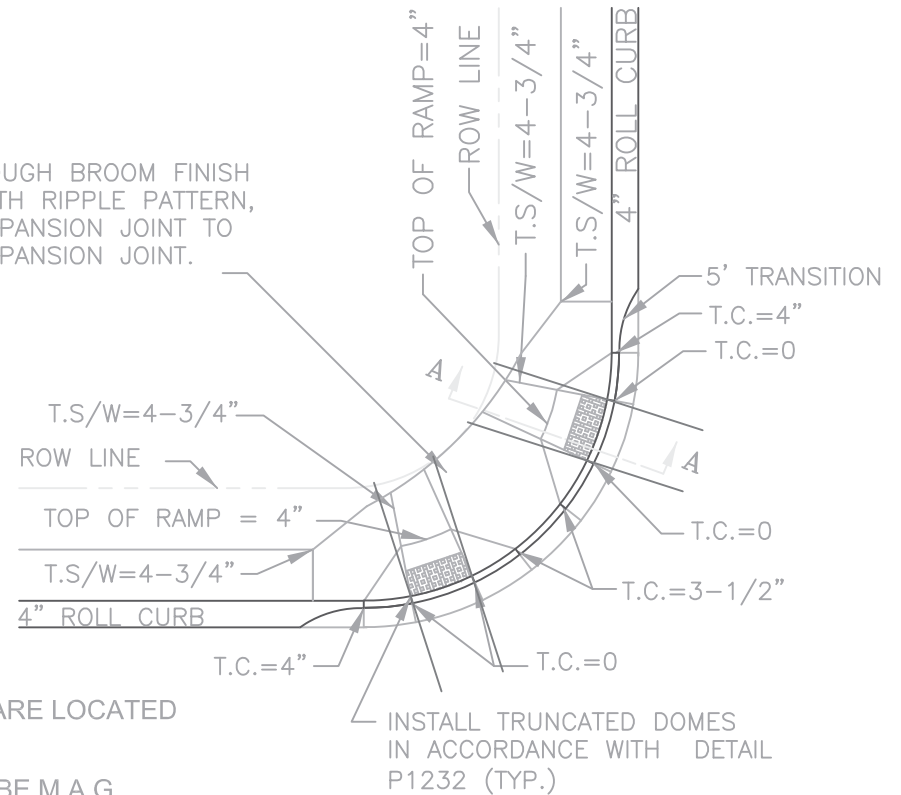

NOTES:

1. CONTROL ELEVATIONS ARE SHOWN IN RELATION TO THE GUTTER AND ARE LOCATED RADIALLY. GUTTER ELEVATION= 0".
2. CONCRETE CURB AND GUTTER AT CURB RETURNS WITH RAMPS SHALL BE M.A.G. CLASS A. CONCRETE SIDEWALKS AND RAMPS AT CURB RETURNS SHALL BE M.A.G. CLASS A.
3. RAMP CURBS MAY BE POURED MONOLITHIC WITH A CONTRACTION JOINT.
4. EXPANSION JOINT FILLER SHALL BE 1/2 " BITUMINOUS TYPE PREFORMED EXPANSION JOINT
5. MAINTAIN THE PLANE OF THE LANDING ONE FOOT (1ft.) BEYOND THE TOP OF LANDING.
6. 9" THICK LANDING, RAMPS, AND CURBS FROM EXPANSION JOINT TO EXPANSION JOINT ON MAJOR OR COLLECTOR STREETS. 4" THICK LANDING AND RAMPS ON LOCAL STREETS.
7. MAINTAIN THE PLANE OF THE LANDING ONE FOOT (1ft.) BEYOND THE TOP OF LANDING.
8. DETAIL PROVIDED FOR GENERAL GUIDANCE. RAMP ELEVATIONS, SLOPES, AND DISTANCES TO BE PROVIDED ON SEALED CONSTRUCTION DOCUMENTS.

## SECTION A-A (TYP.)

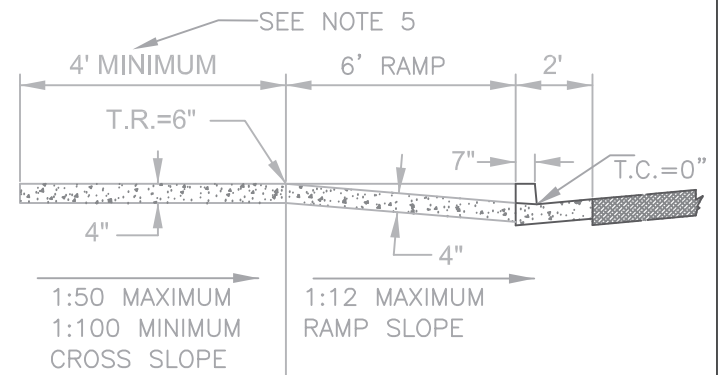

# SECTION A-A (TYP.)

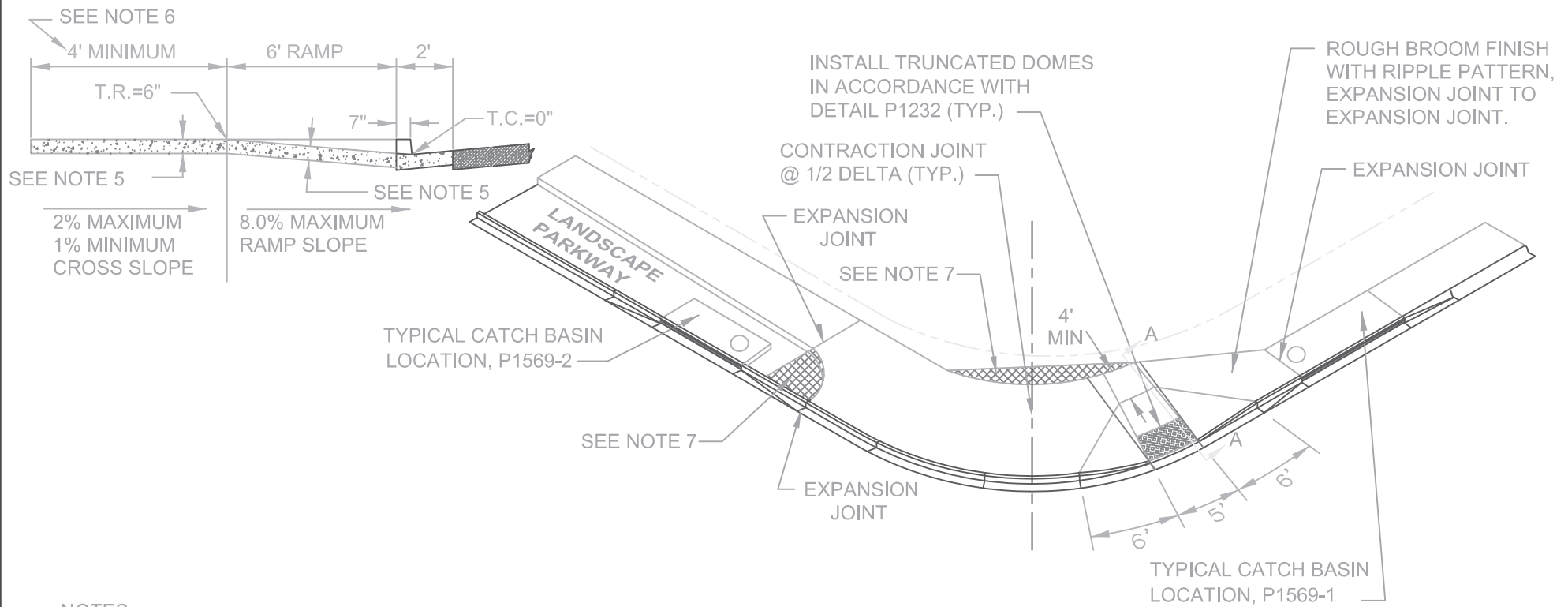

## NOTES:

- CONTROL ELEVATIONS ARE SHOWN IN RELATION TO THE GUTTER AND ARE LOCATED RADIALLY. GUTTER ELEVATION=0".
- CONCRETE CURB AND GUTTER AT CURB RETURNS WITH RAMPS SHALL BE M.A.G. CLASS A. CONCRETE SIDEWALKS AND RAMPS AT CURB RETURNS SHALL BE M.A.G. CLASS A.
- RAMP CURBS MAY BE POURED MONOLITHIC WITH A CONTRACTION JOINT.
- EXPANSION JOINT FILLER SHALL BE 1/2" BITUMINOUS TYPE PREFORMED EXPANSION JOINT FILLER A.S.T.M. D-1751
- 9" THICK LANDING, RAMPS, AND CURBS FROM EXPANSION JOINT TO EXPANSION JOINT ON MAJOR OR COLLECTOR STREETS. 4" THICK LANDING AND RAMPS ON LOCAL STREETS.
- MAINTAIN THE PLANE OF THE LANDING ONE FOOT (1ft.) BEYOND THE TOP OF LANDING.
- ADDITIONAL SIDEWALK PER NOTE 2 & 5 WHEN SIGNAL POLES ARE LOCATED IN THESE AREAS.
- DETAIL PROVIDED FOR GENERAL GUIDANCE. RAMP ELEVATIONS, SLOPES, AND DISTANCES TO BE PROVIDED ON SEALED CONSTRUCTION DOCUMENTS. .

DETAIL NO.  
P1240



**City of Phoenix**  
**STANDARD DETAIL**

SINGLE CURB RAMP DETAIL  
ALL RADIUS CURB RETURNS

APPROVED

*E. J. [Signature]*  
CITY ENGINEER

04/01/2022  
DATE

DETAIL NO.  
P1240

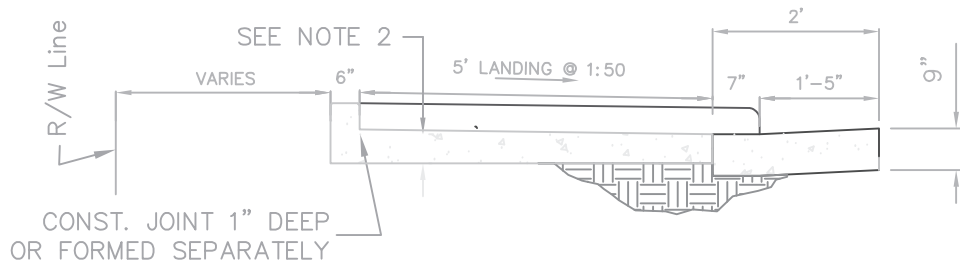

**SECTION A-A**

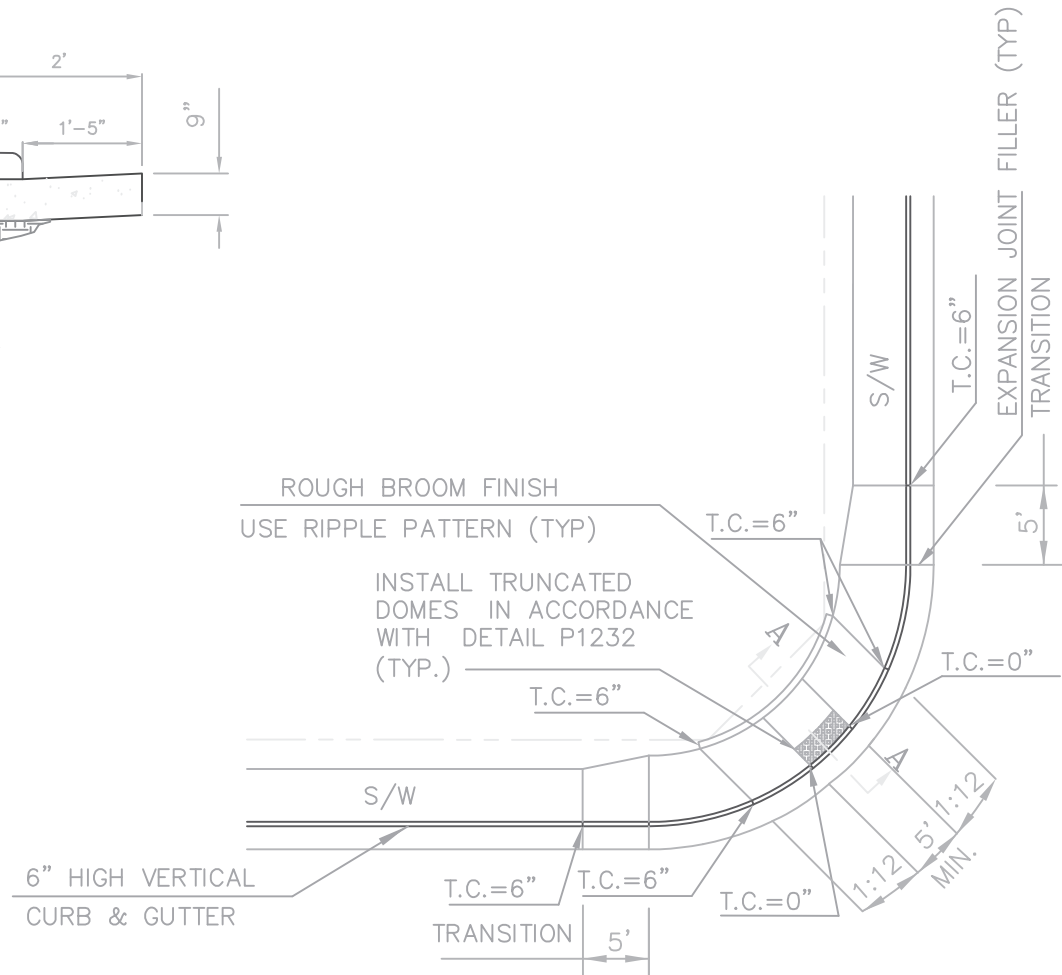

**NOTES:**

- 1) CONCRETE CURB & GUTTER AT CURB RETURNS WITH RAMPS SHALL BE M.A.G. CLASS A. CONCRETE SIDEWALK AND RAMPS AT CURB RETURNS SHALL BE M.A.G. CLASS A.
- 2) 9" LANDING AND RAMPS ON MAJOR OR COLLECTOR STREETS AND 4" LANDING AND RAMPS ON LOCAL STREETS.
- 3) DETAIL PROVIDED FOR GENERAL GUIDANCE. RAMP ELEVATIONS, SLOPES, AND DISTANCES TO BE PROVIDED ON SEALED CONSTRUCTION DOCUMENTS.



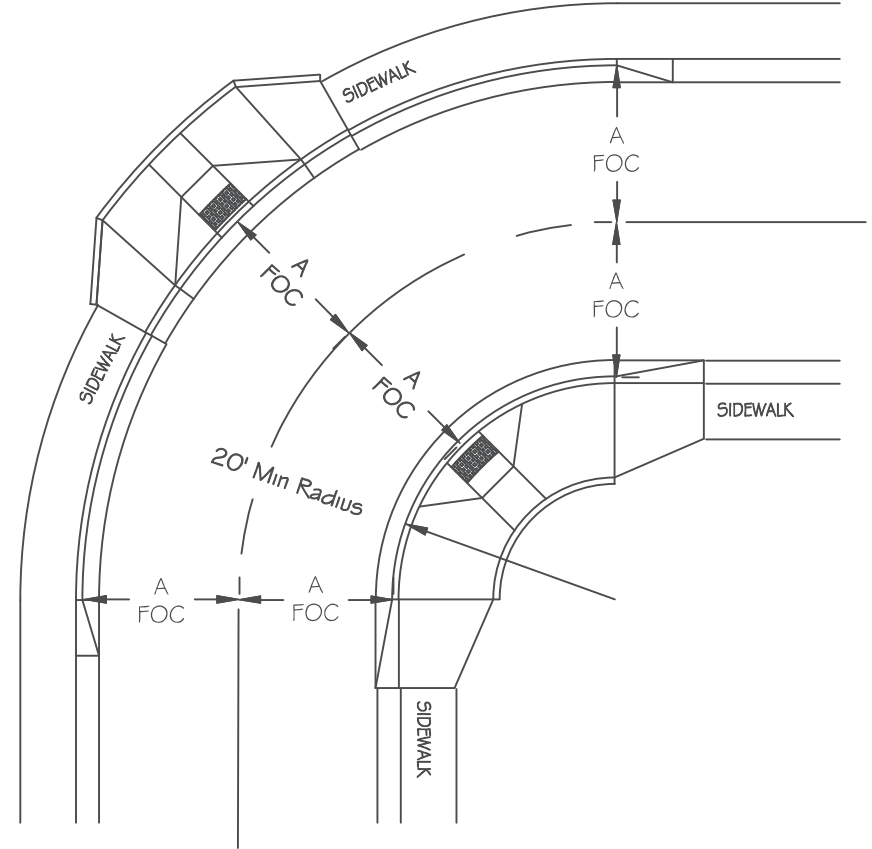
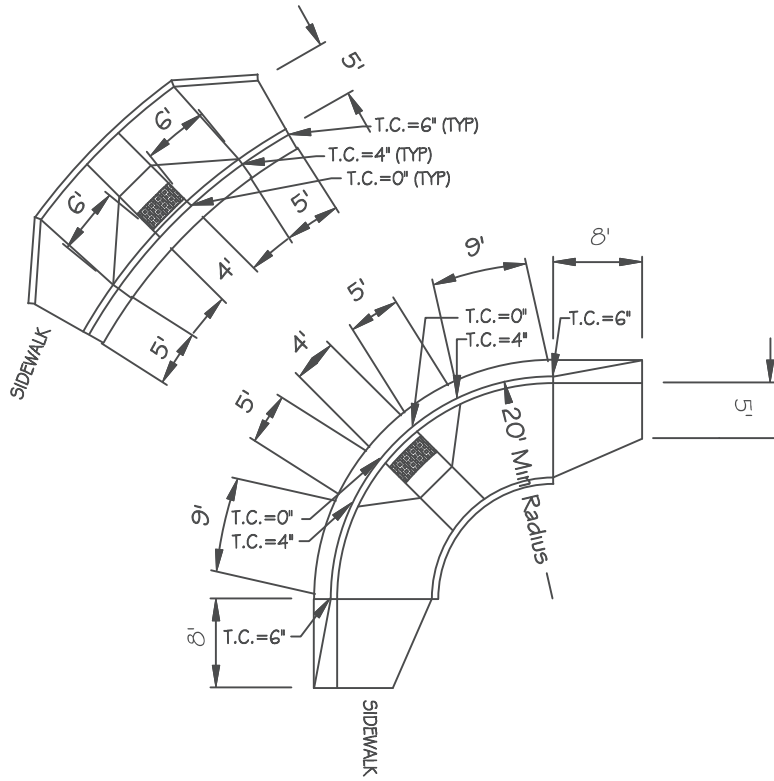

1. DETAIL PROVIDED FOR GENERAL GUIDANCE. RAMP ELEVATIONS, SCOPES, AND DISTANCES TO BE PROVIDED ON SEALED CONSTRUCTION DOCUMENTS.





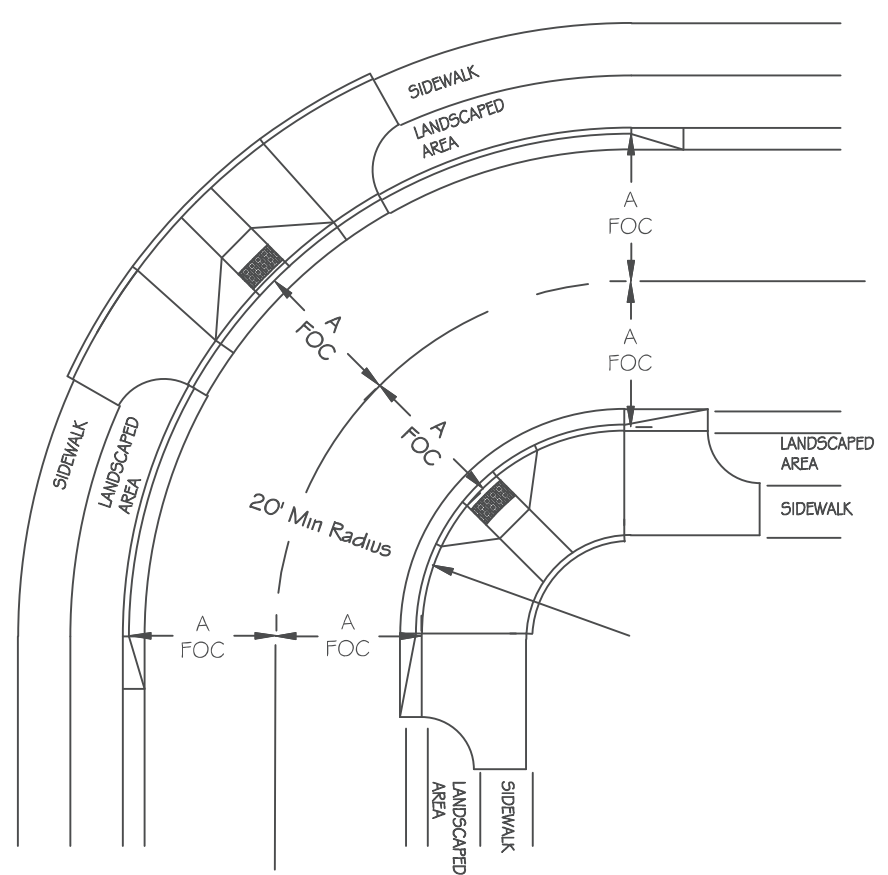
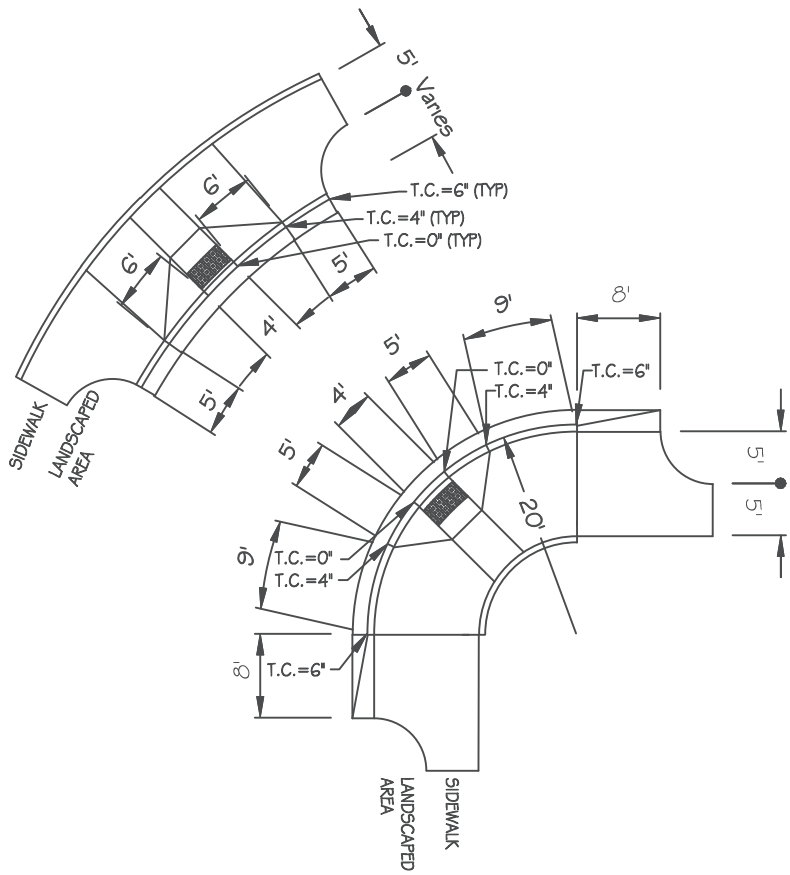

1. DETAIL PROVIDED FOR GENERAL GUIDANCE. RAMP ELEVATIONS, SLOPES, AND DISTANCES TO BE PROVIDED ON SEALED CONSTRUCTION DOCUMENTS.

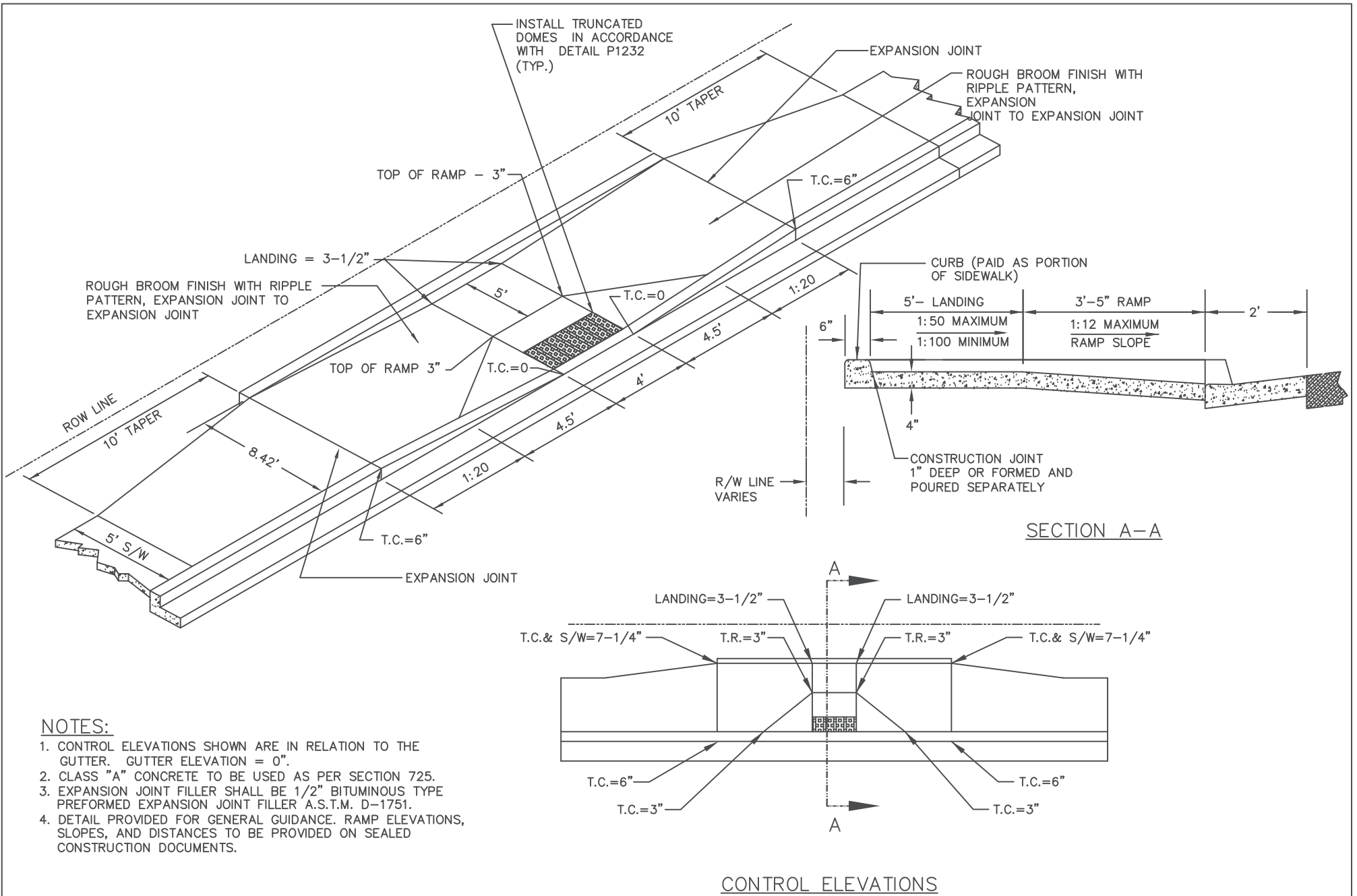

**NOTES:**

1. CONTROL ELEVATIONS SHOWN ARE IN RELATION TO THE GUTTER. GUTTER ELEVATION = 0".
2. CLASS "A" CONCRETE TO BE USED AS PER SECTION 725.
3. EXPANSION JOINT FILLER SHALL BE 1/2" BITUMINOUS TYPE PREFORMED EXPANSION JOINT FILLER A.S.T.M. D-1751.
4. DETAIL PROVIDED FOR GENERAL GUIDANCE. RAMP ELEVATIONS, SLOPES, AND DISTANCES TO BE PROVIDED ON SEALED CONSTRUCTION DOCUMENTS.

**CONTROL ELEVATIONS**

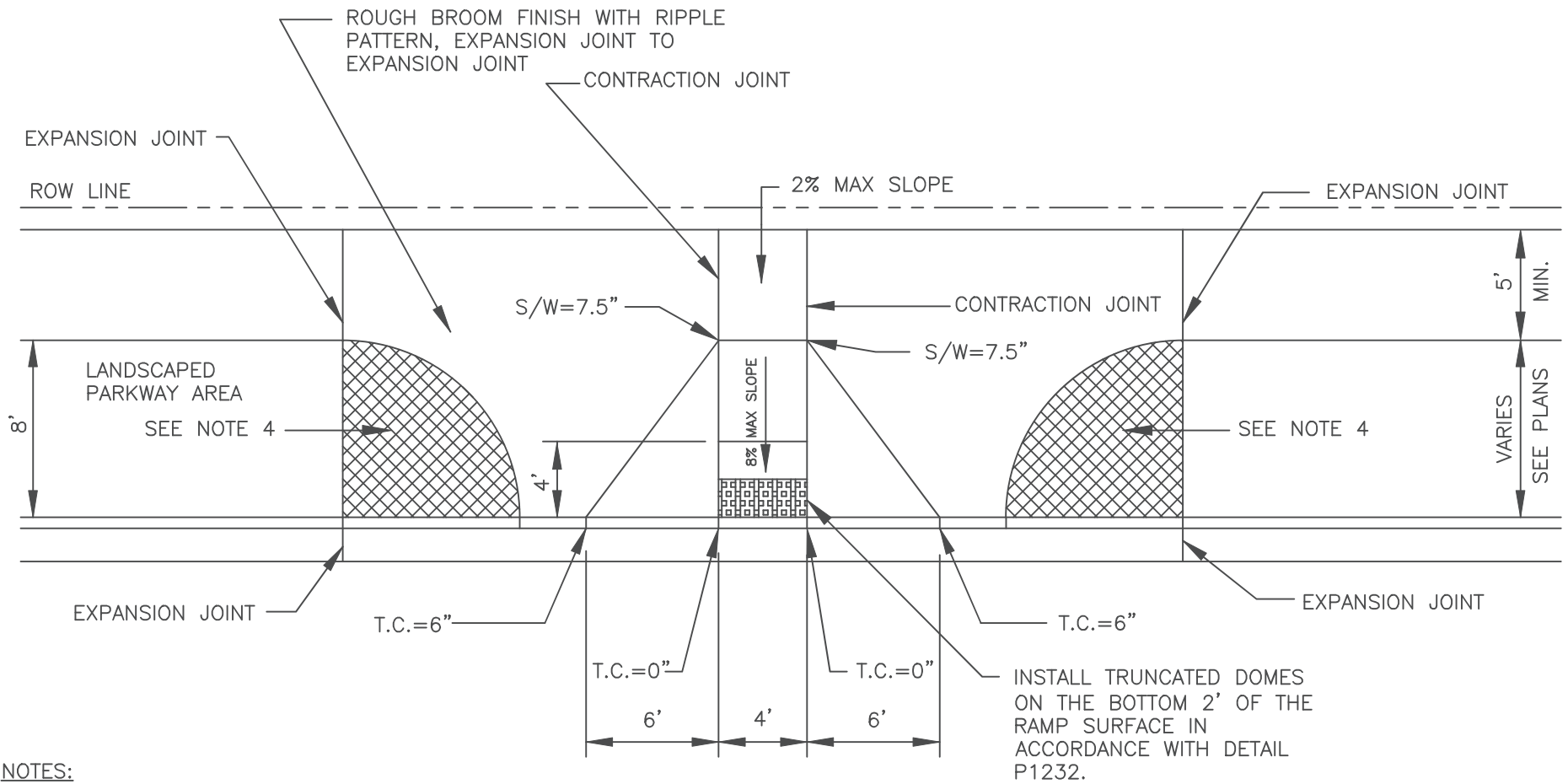

**NOTES:**

1. CONTROL ELEVATIONS SHOWN ARE IN RELATION TO THE GUTTER. GUTTER ELEVATION = 0".
2. CLASS "A" CONCRETE TO BE USED AS PER SECTION 725.
3. EXPANSION JOINT FILLER SHALL BE 1/2" BITUMINOUS TYPE PREFORMED EXPANSION JOINT FILLER A.S.T.M. D-1751.
4. ADDITIONAL SIDEWALK PER NOTE 2 WHEN SIGNAL POLES ARE LOCATED IN THESE AREAS.
5. DETAIL PROVIDED FOR GENERAL GUIDANCE. RAMP ELEVATIONS, SLOPES, AND DISTANCES TO BE PROVIDED ON SEALED CONSTRUCTION DOCUMENTS.

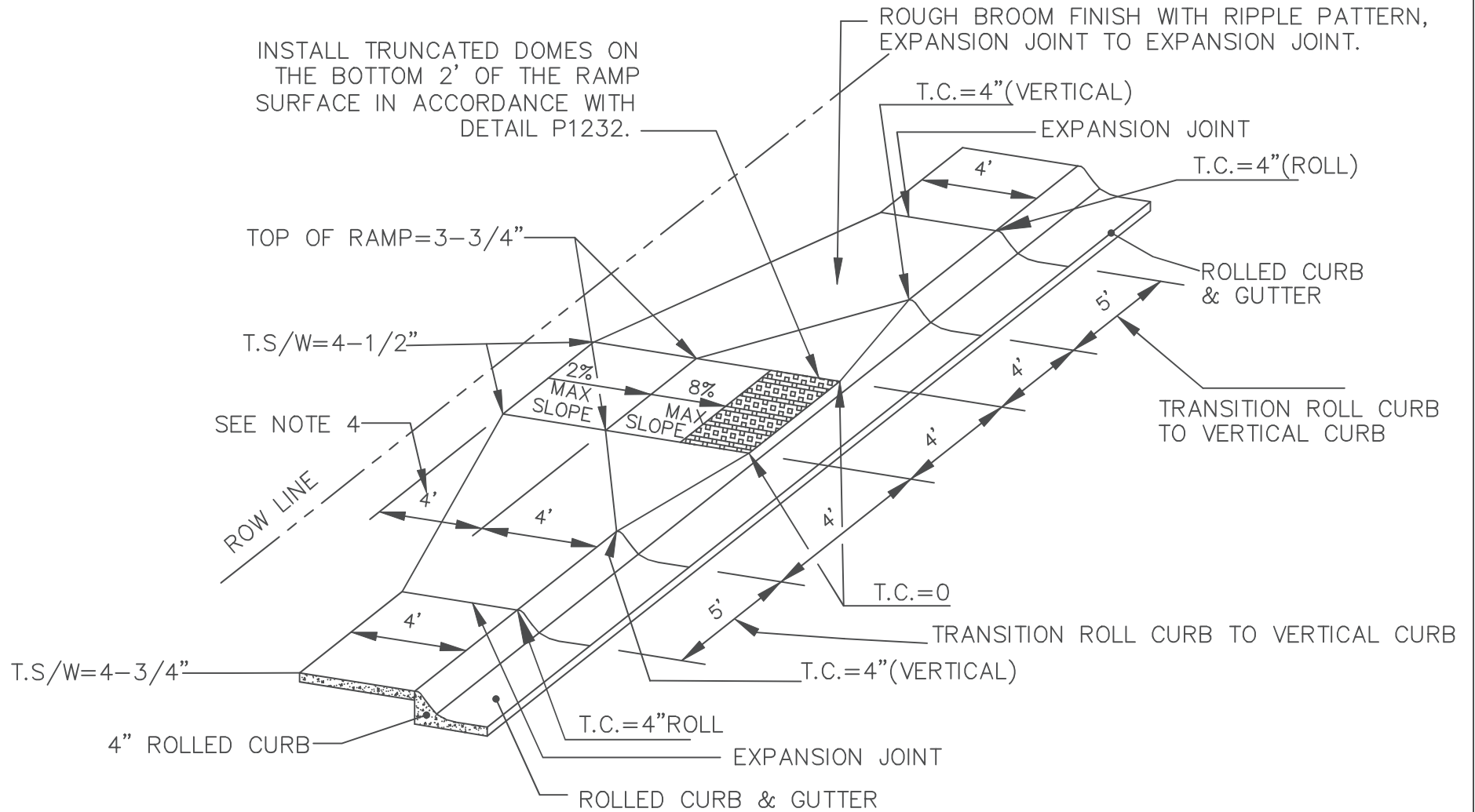

NOTES:

- CONTROL ELEVATIONS SHOWN ARE IN RELATION TO THE GUTTER. GUTTER ELEVATION = 0".
- CLASS "A" CONCRETE TO BE USED AS PER SECTION 725.
- EXPANSION JOINT FILLER SHALL BE 1/2" BITUMINOUS TYPE PREFORMED EXPANSION JOINT FILLER A.S.T.M. D-1751.
- MAINTAIN THE PLANE OF THE LANDING ONE FOOT (1ft.) BEYOND THE TOP OF THE LANDING.
- DETAIL PROVIDED FOR GENERAL GUIDANCE. RAMP ELEVATIONS, SLOPES, AND DISTANCES TO BE PROVIDED ON SEALED CONSTRUCTION DOCUMENTS.

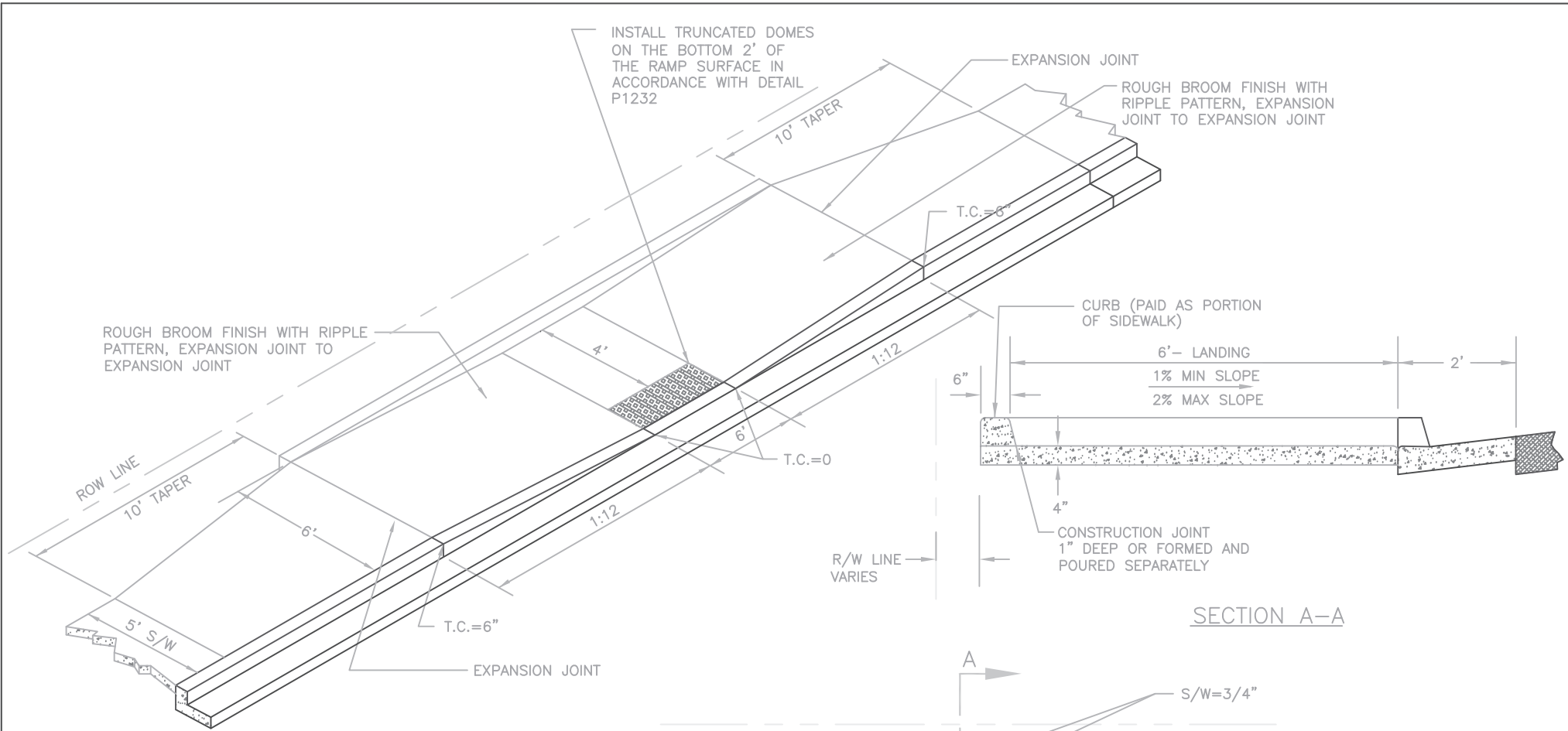

SECTION A-A

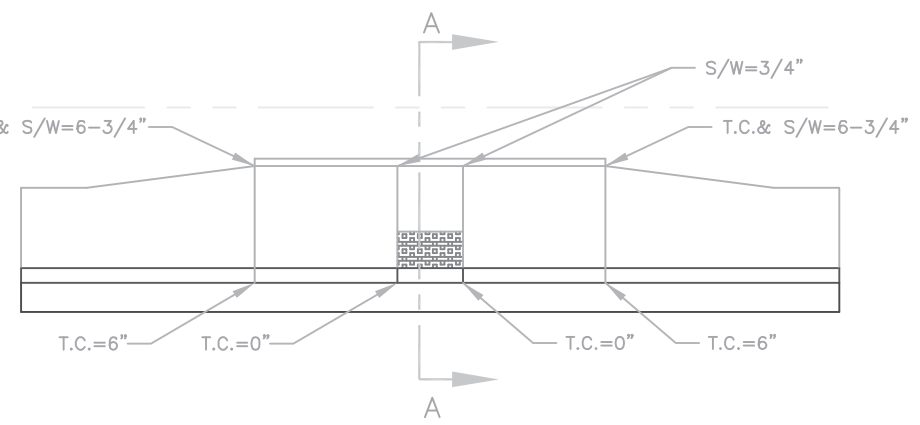

CONTROL ELEVATIONS

NOTES:

1. CONTROL ELEVATIONS SHOWN ARE IN RELATION TO THE GUTTER. GUTTER ELEVATION = 0".
2. CLASS "A" CONCRETE TO BE USED AS PER SECTION 725.
3. EXPANSION JOINT FILLER SHALL BE 1/2" BITUMINOUS TYPE PREFORMED EXPANSION JOINT FILLER A.S.T.M. D-1751.
4. DETAIL PROVIDED FOR GENERAL GUIDANCE. RAMP ELEVATIONS, SLOPES, AND DISTANCES TO BE PROVIDED ON SEALED CONSTRUCTION DOCUMENTS.

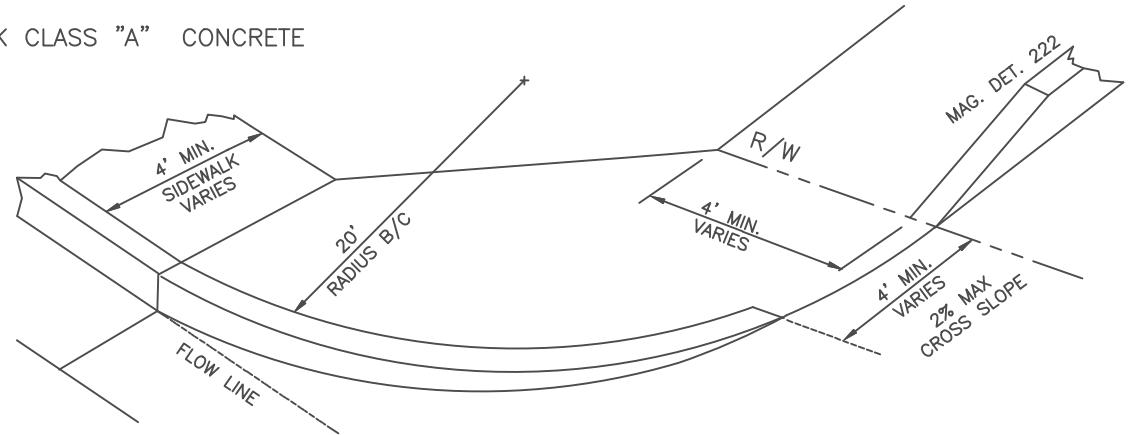
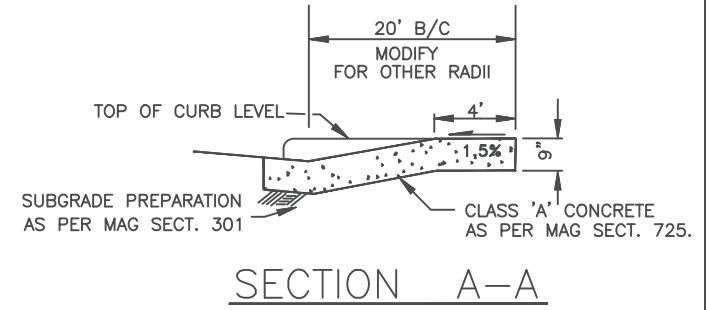
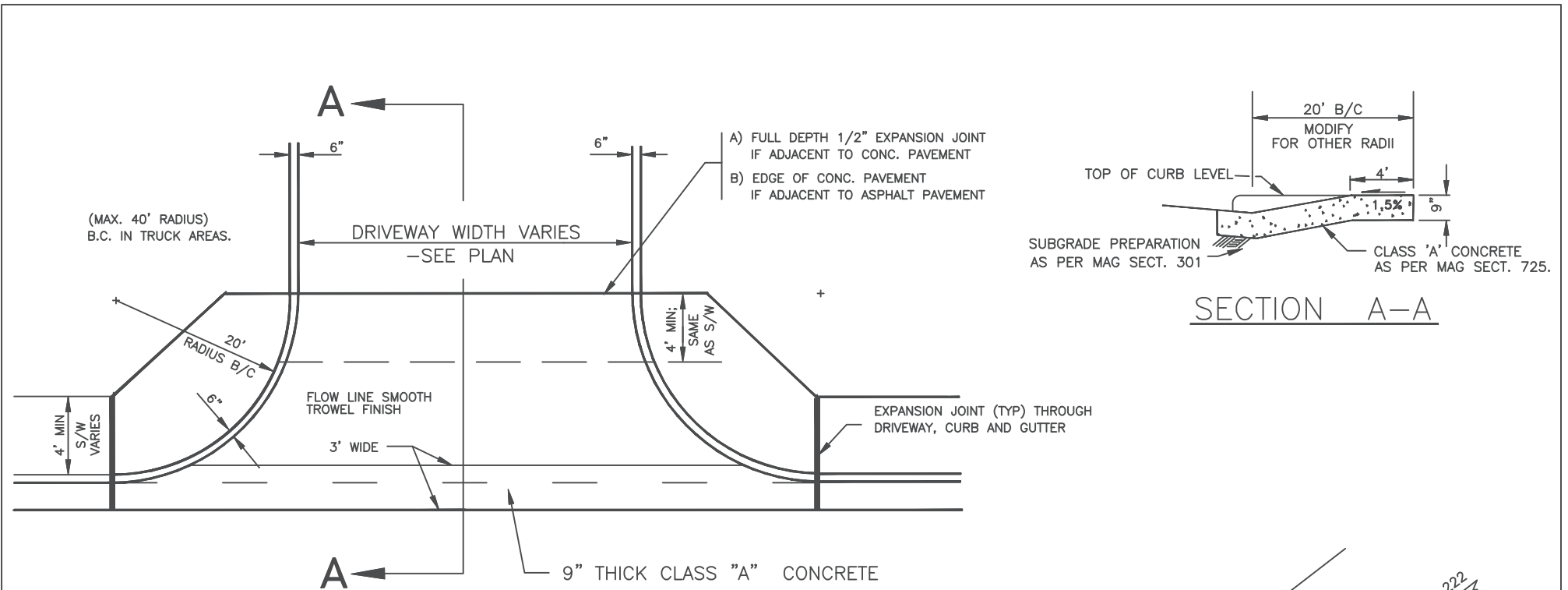

- NOTES:
- CONTROL ELEVATIONS ARE IN RELATION TO THE GUTTER AND ARE LOCATED RADIALLY. GUTTER ELEVATION = 0".
  - CONCRETE CURB & GUTTER AT CURB RETURNS WITH RAMPS SHALL BE M.A.G. CLASS A. CONCRETE SIDEWALK AND RAMPS AT CURB RETURNS SHALL BE M.A.G. CLASS A.
  - RAMP CURBS MAY BE POURED MONOLITHIC WITH A CONSTRUCTION JOINT.
  - EXPANSION JOINT FILLER SHALL BE 1/2" BITUMINOUS TYPE PREFORMED EXPANSION JOINT FILLER A.S.T.M. D-1751
  - MEASUREMENT AND PAYMENT FOR CONCRETE DRIVEWAY SHALL BE BY THE SQUARE FOOT OF 9" CLASS "A" CONCRETE PLACED. MEASUREMENT AND PAYMENT FOR THE CURB RETURNS AND THE SIDEWALK AT THE RETURNS SHALL BE MADE UNDER THEIR SEPARATE PAY ITEMS.

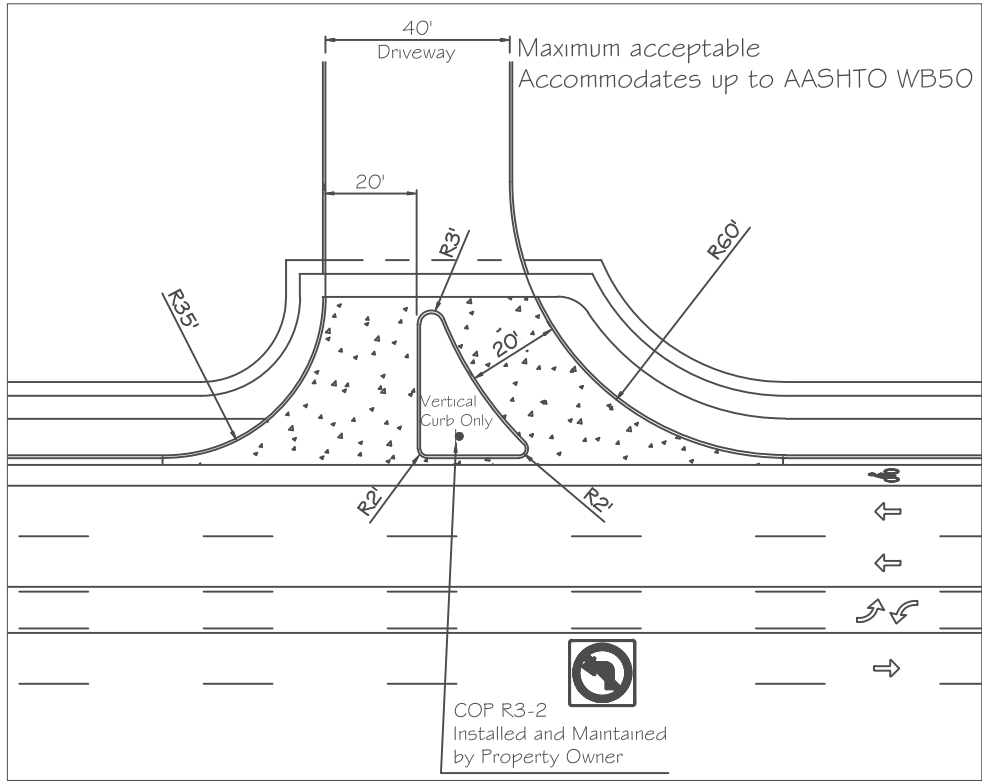
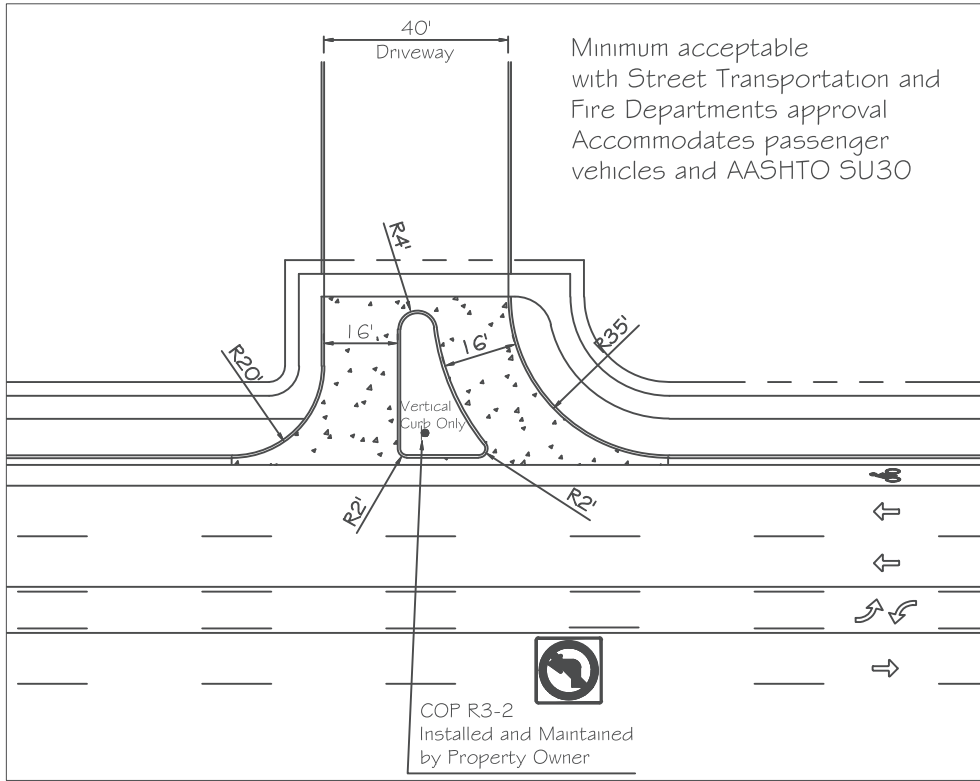

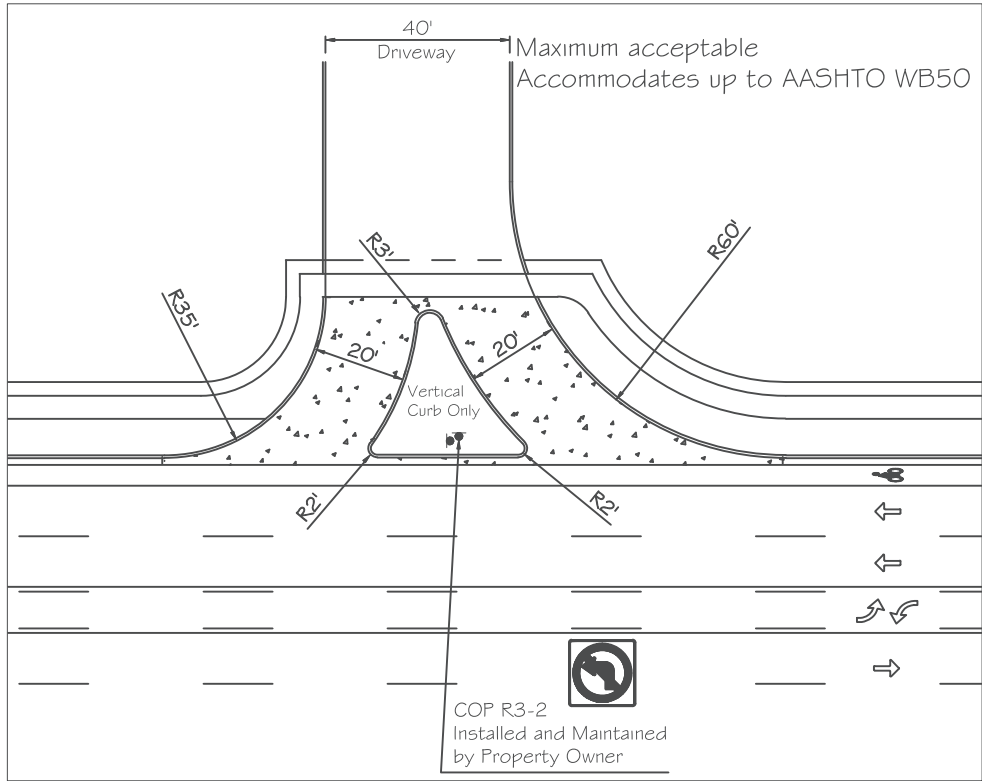
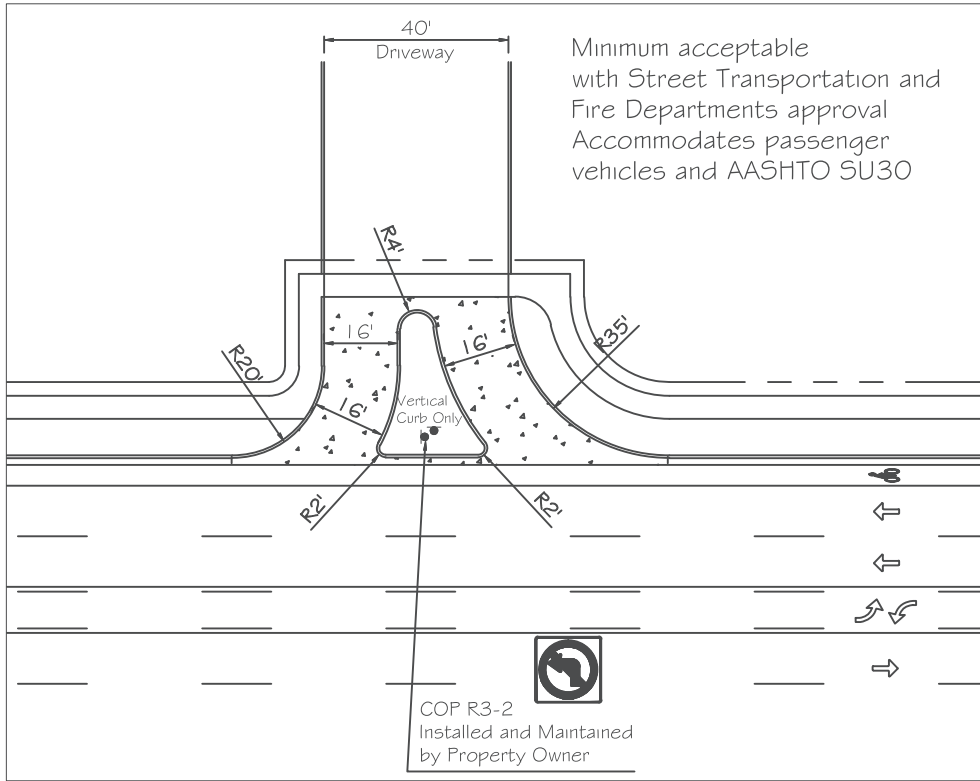



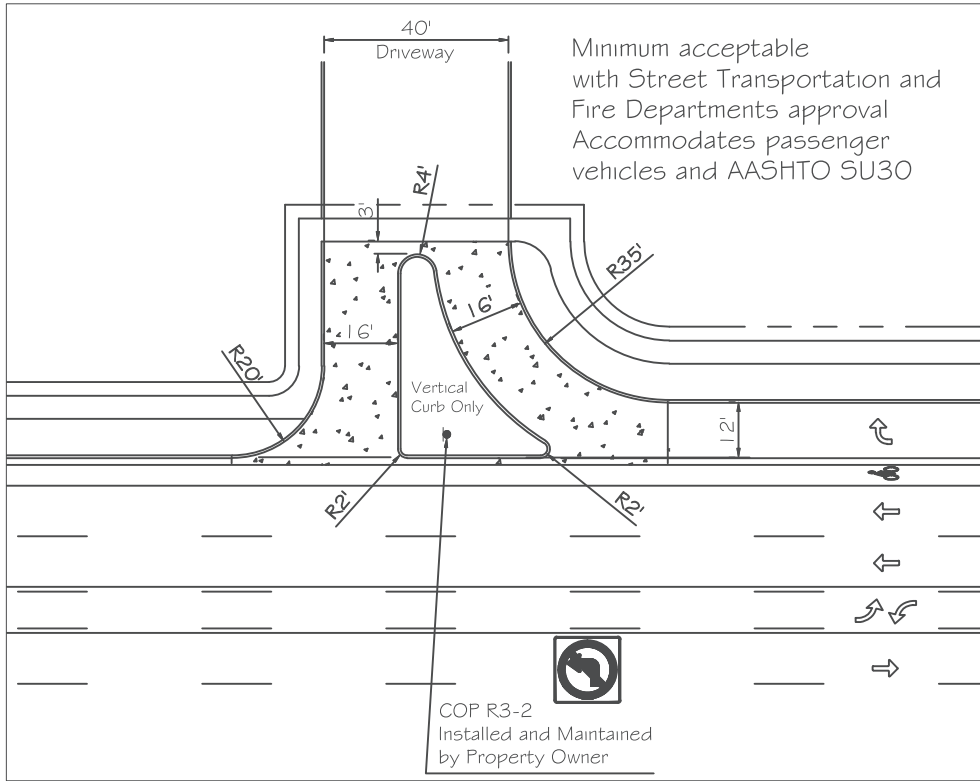

WITH DECELERATION LANE  
PREVENTS LEFT TURN IN  
35' RETURN

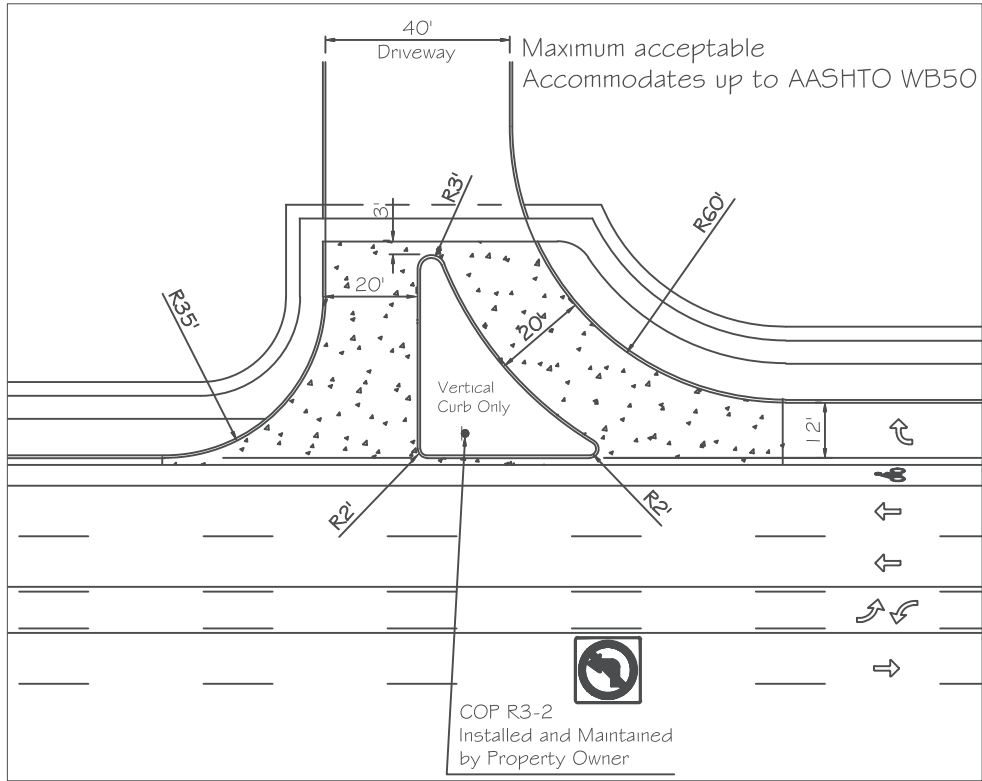

WITH DECELERATION LANE  
PREVENTS LEFT TURN IN  
60' RETURN

DETAIL NO.  
P1243-3



**City of Phoenix**  
**STANDARD DETAIL**

LIMITED ACCESS DRIVEWAY WITH NO LT-IN  
AND WITH DECELERATION LANE

APPROVED

*[Signature]*  
CITY ENGINEER

07/01/2015  
DATE

DETAIL NO.  
P1243-3

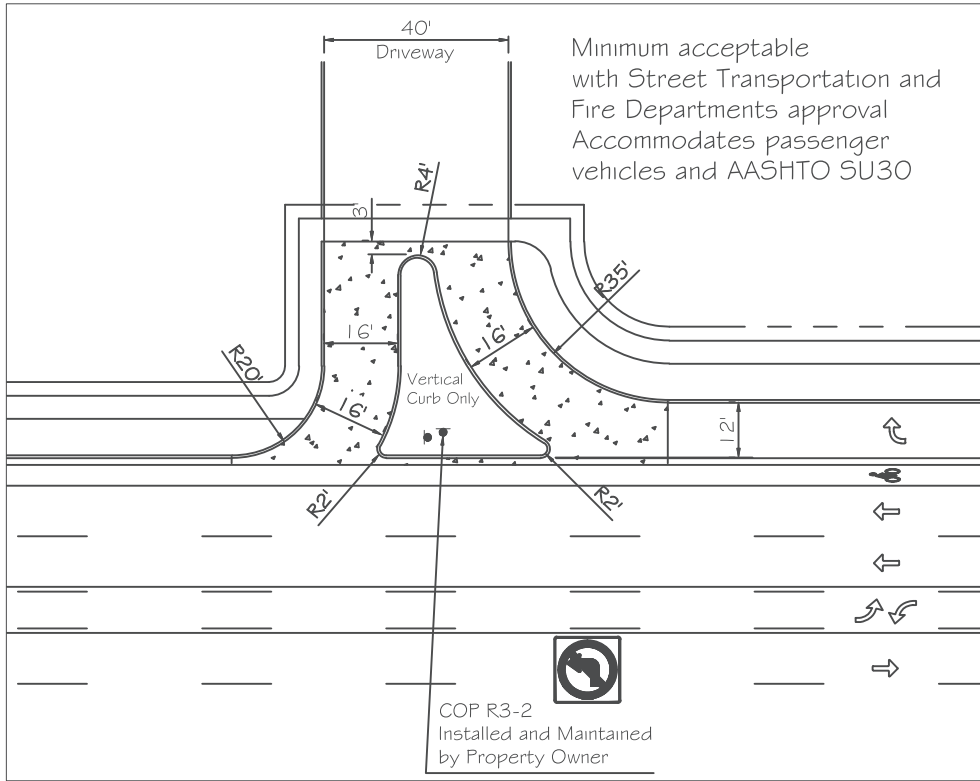

WITH DECELERATION LANE  
PREVENTS LEFT TURN IN/OUT  
35' RETURN

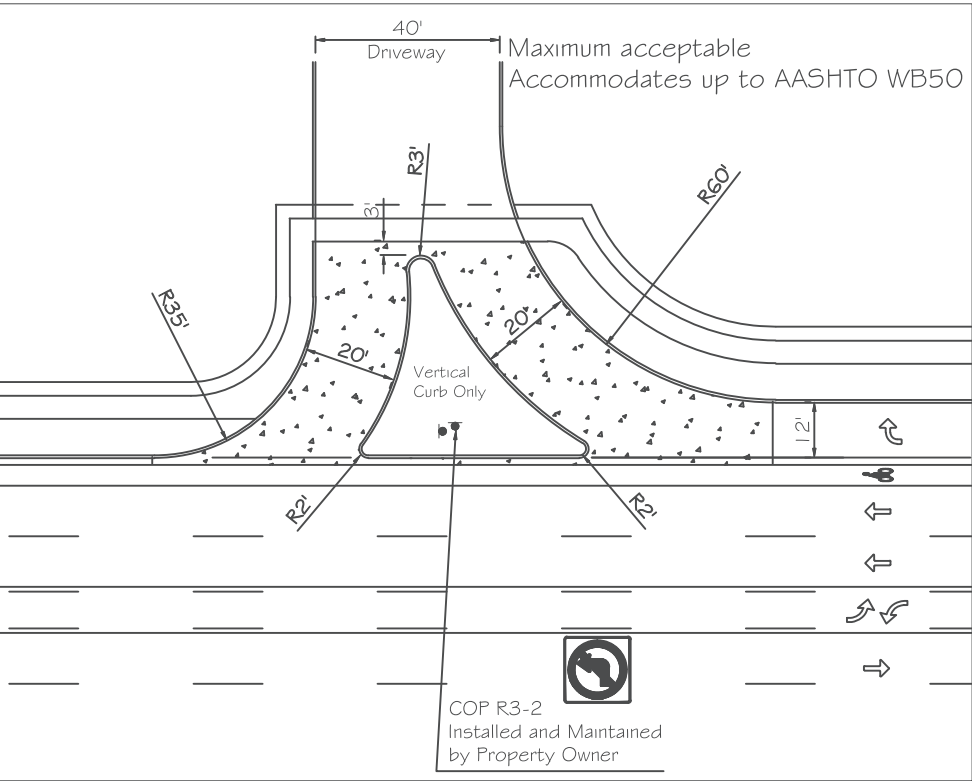

WITH DECELERATION LANE  
PREVENTS LEFT TURN IN/OUT  
60' RETURN

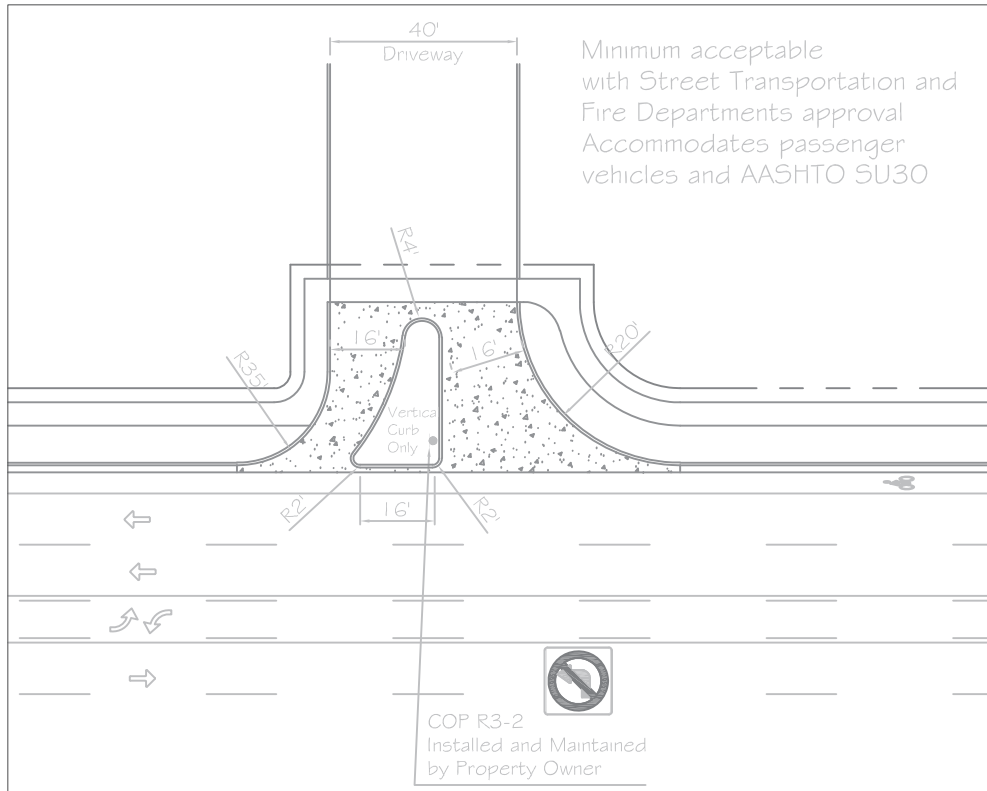

WITHOUT DECELERATION LANE  
PREVENTS LEFT TURN IN 35' RETURN

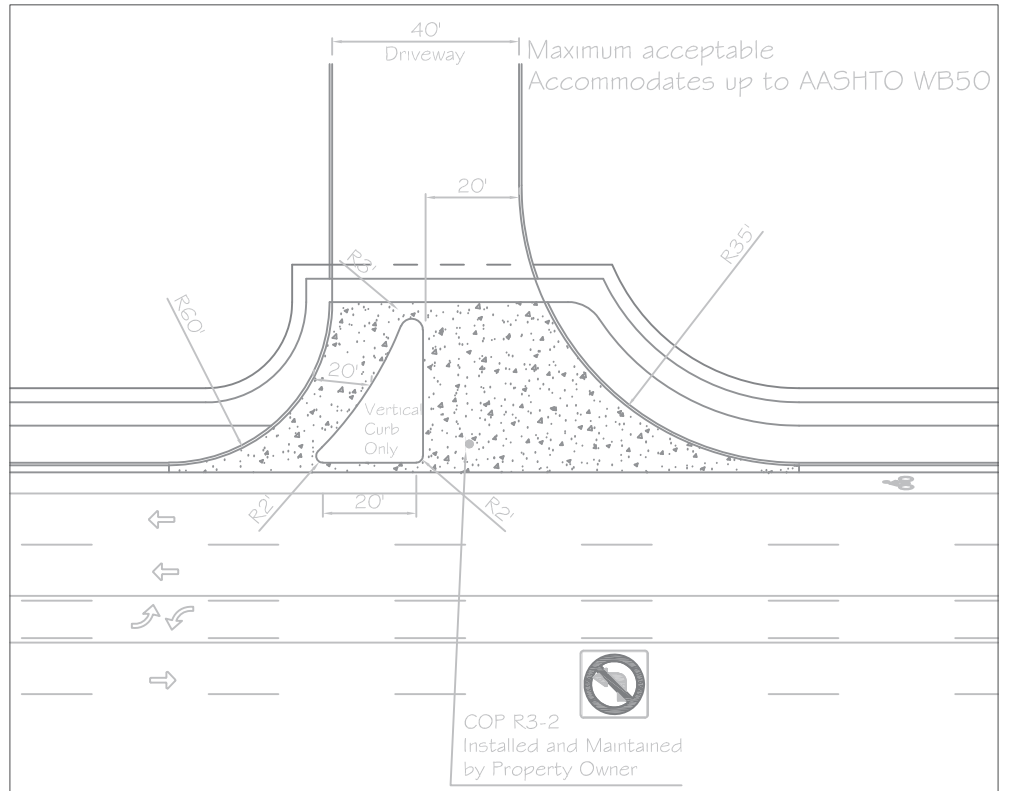

WITHOUT DECELERATION LANE  
PREVENTS LEFT TURN IN 60' RETURN

DETAIL NO.  
P1243-5



**City of Phoenix**  
**STANDARD DETAIL**

LIMITED ACCESS DRIVEWAY WITH NO LT-OUT  
AND WITHOUT DECELERATION LANE

APPROVED

*E. J. [Signature]*  
CITY ENGINEER

04/01/2022  
DATE

DETAIL NO.  
P1243-5

FULL DEPTH EXPANSION JOINT THROUGH DRIVEWAY,  
CURB & GUTTER. EXPANSION JOINT  
FILLER SHALL BE 1/2" BITUMINOUS TYPE  
PREFORMED EXPANSION JOINT FILLER  
A.S.T.M. D-1751.

PROVIDE CONSTRUCTION JOINTS  
TO MATCH CURB JOINTS.  
(10' SPACING)

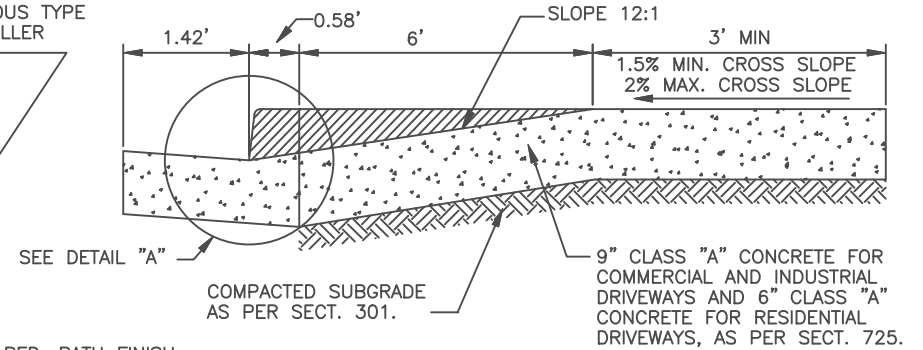
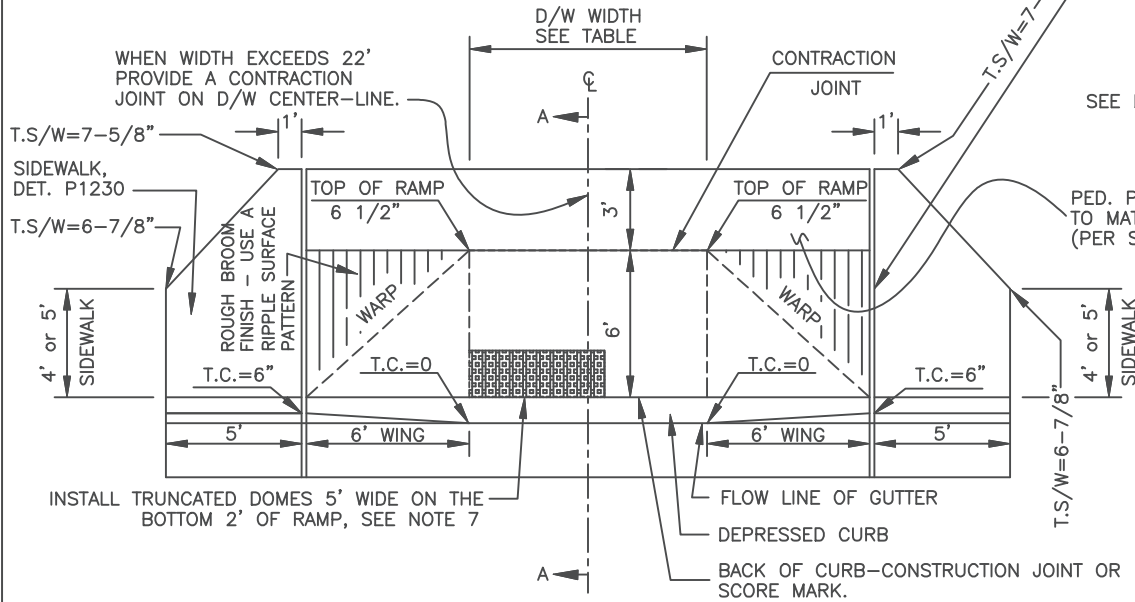

SECTION A-A

NOTES:

1. THIS DETAIL IS ONLY TO BE USED WHEN APPROVED BY THE CITY.
2. DEPRESSED CURB SHALL BE PAID FOR AS COMBINED CURB AND GUTTER.
3. CONCRETE CURB & GUTTER SHALL BE M.A.G. CLASS A;  
TOP OF WING TO TOP OF WING.
4. PAYMENT FOR DRIVEWAY SHALL BE ON A SQUARE FOOT BASIS.
5. EXPANSION JOINT MATERIAL SHALL BE SECURED IN PLACE PRIOR TO  
POURING CONCRETE AND SHALL COMPLETELY SEPARATE THE DRIVEWAY  
SLAB FROM THE SIDEWALK, EXTENDING FROM THE SURFACE  
TO THE SUBGRADE.
6. CONTROL ELEVATIONS SHOWN ARE IN RELATION TO GUTTER.  
GUTTER ELEVATION = 0
7. TRUNCATED DOMES SHALL BE INSTALLED AT THE BACK OF CURB IN A 2-FT  
DEEP BY 5-FT WIDE AREA LOCATED AT EITHER THE RIGHT OR LEFT END  
OF THE DRIVEWAY ENTRANCE, WHICHEVER WILL PROVIDE THE MOST DIRECT  
ALIGNMENT WITH THE RECEIVER CURB RAMP ON THE OPPOSITE CURB.  
TRUNCATED DOMES TO BE IN ACCORDANCE WITH DETAIL P1232.

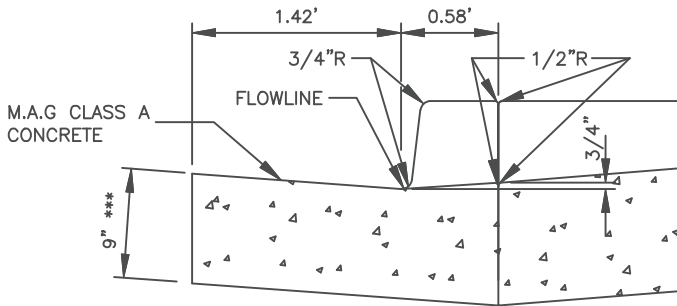

DETAIL "A"

Refer to P1255-4 for  
Driveway Widths Policy

PROVIDE CONSTRUCTION JOINTS TO MATCH CURB JOINTS. (10' SPACING)

FULL DEPTH EXPANSION JOINT THROUGH DRIVEWAY, CURB & GUTTER. EXPANSION JOINT FILLER SHALL BE 1/2" BITUMINOUS TYPE PREFORMED EXPANSION JOINT FILLER A.S.T.M. D-1751.

WHEN WIDTH EXCEEDS 22' PROVIDE A CONTRACTION JOINT ON D/W CENTER-LINE.

D/W WIDTH SEE TABLE

CONTRACTION JOINT

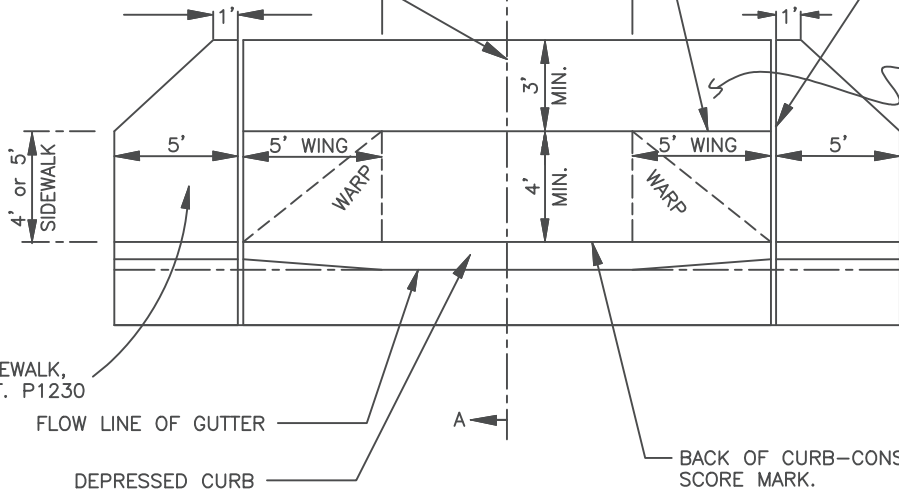

SIDEWALK, DET. P1230

FLOW LINE OF GUTTER

DEPRESSED CURB

BACK OF CURB-CONSTRUCTION JOINT OR SCORE MARK.

PED. PATH TO MATCH S/W. FINISH PER ST. DET. P1230

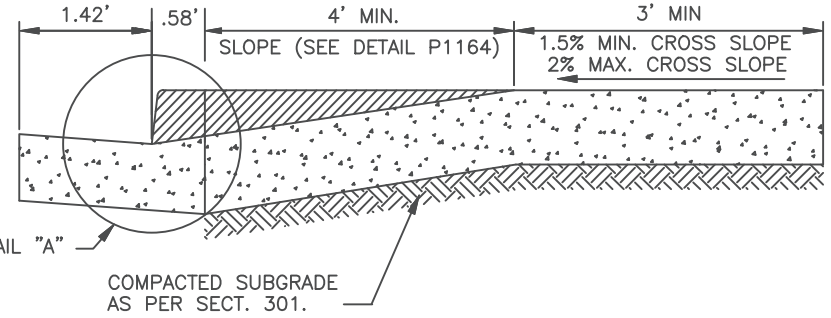

SECTION A-A

NOTES

1. DEPRESSED CURB SHALL BE PAID FOR AS COMBINED CURB AND GUTTER.
2. CONCRETE CURB & GUTTER SHALL BE M.A.G. CLASS A; TOP OF WING TO TOP OF WING.
2. PAYMENT FOR DRIVEWAY SHALL BE ON A SQUARE FOOT BASIS.
3. EXPANSION JOINT MATERIAL SHALL BE SECURED IN PLACE PRIOR TO POURING CONCRETE AND SHALL COMPLETELY SEPARATE THE DRIVEWAY SLAB FROM THE SIDEWALK, EXTENDING FROM THE SURFACE TO THE SUBGRADE.
4. WHEN DRIVEWAY IS CONSTRUCTED AT A "T" INTERSECTION AND IS USED AS A RAMP, USE DETAIL P1244.
5. 9" CLASS "A" CONCRETE FOR COMMERCIAL AND INDUSTRIAL DRIVEWAYS AND 6" CLASS "A" CONCRETE FOR RESIDENTIAL DRIVEWAYS, AS PER SECT. 725.

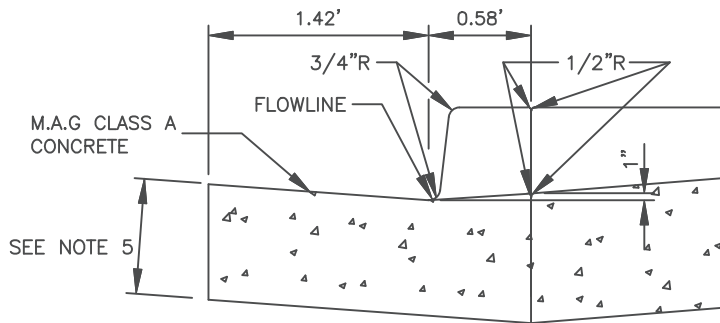

DETAIL "A"

Refer to P1255-4 for Driveway Widths Policy

PROVIDE CONSTRUCTION JOINTS TO MATCH CURB JOINTS. (10' SPACING)

WHEN WIDTH EXCEEDS 22' PROVIDE A CONTRACTION JOINT ON D/W CENTER-LINE.

D/W WIDTH - SEE TABLE

BACK OF CURB - CONSTRUCTION JOINT OR SCORE MARK.

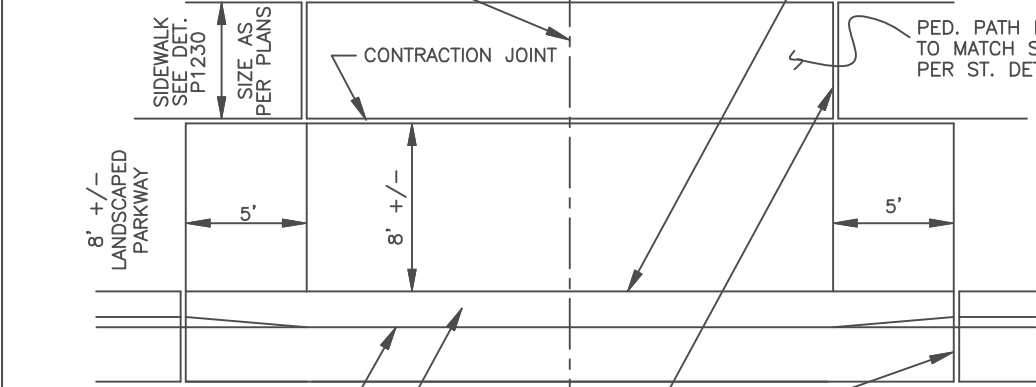

FLOW LINE OF GUTTER

DEPRESSED CURB

PED. PATH FINISH TO MATCH S/W. PER ST. DET. P1230

EXPANSION JOINT THROUGH SIDEWALK AND CURB & GUTTER. EXPANSION JOINT FILLER SHALL BE 1/2" BITUMINOUS TYPE PREFORMED EXPANSION JOINT FILLER A.S.T.M. D-1751.

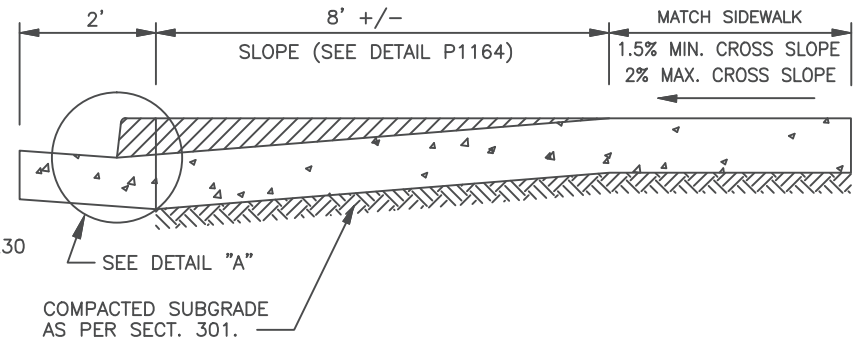

SECTION A-A

NOTES

1. DEPRESSED CURB SHALL BE PAID FOR AS COMBINED CURB AND GUTTER.
2. CONCRETE CURB & GUTTER SHALL BE M.A.G. CLASS A; TOP OF WING TO TOP OF WING.
3. PAYMENT FOR DRIVEWAY SHALL BE ON A SQUARE FOOT BASIS.
4. EXPANSION JOINT MATERIAL SHALL BE SECURED IN PLACE PRIOR TO POURING CONCRETE AND SHALL COMPLETELY SEPARATE THE DRIVEWAY SLAB FROM THE SIDEWALK, EXTENDING FROM THE SURFACE TO THE SUBGRADE.
5. WHEN DRIVEWAY IS CONSTRUCTED AT A "T" INTERSECTION AND IS USED AS A RAMP, THE SLOPE OF THE DRIVEWAY SHALL BE A MAX OF 12:1, AND WILL HAVE TRUNCATED DOMES INSTALLED AT THE BACK OF CURB IN A 2-FT DEEP BY 5-FT WIDE AREA LOCATED AT EITHER THE RIGHT OR LEFT END OF THE DRIVEWAY ENTRANCE, WHICHEVER WILL PROVIDE THE MOST DIRECT ALIGNMENT WITH THE RECEIVER CURB RAMP ON THE OPPOSITE CURB. TRUNCATED DOMES TO BE IN ACCORDANCE WITH DETAIL P1232.
6. 9" CLASS "A" CONCRETE FOR COMMERCIAL AND INDUSTRIAL DRIVEWAYS AND 6" CLASS "A" CONCRETE FOR RESIDENTIAL DRIVEWAYS, AS PER SECT. 725.

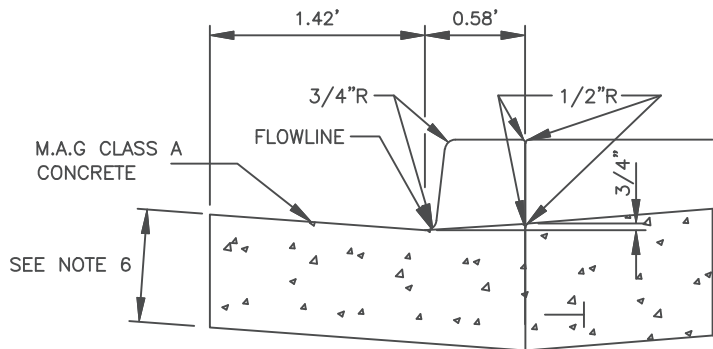

DETAIL "A"

Refer to P1255-4 for Driveway Widths Policy

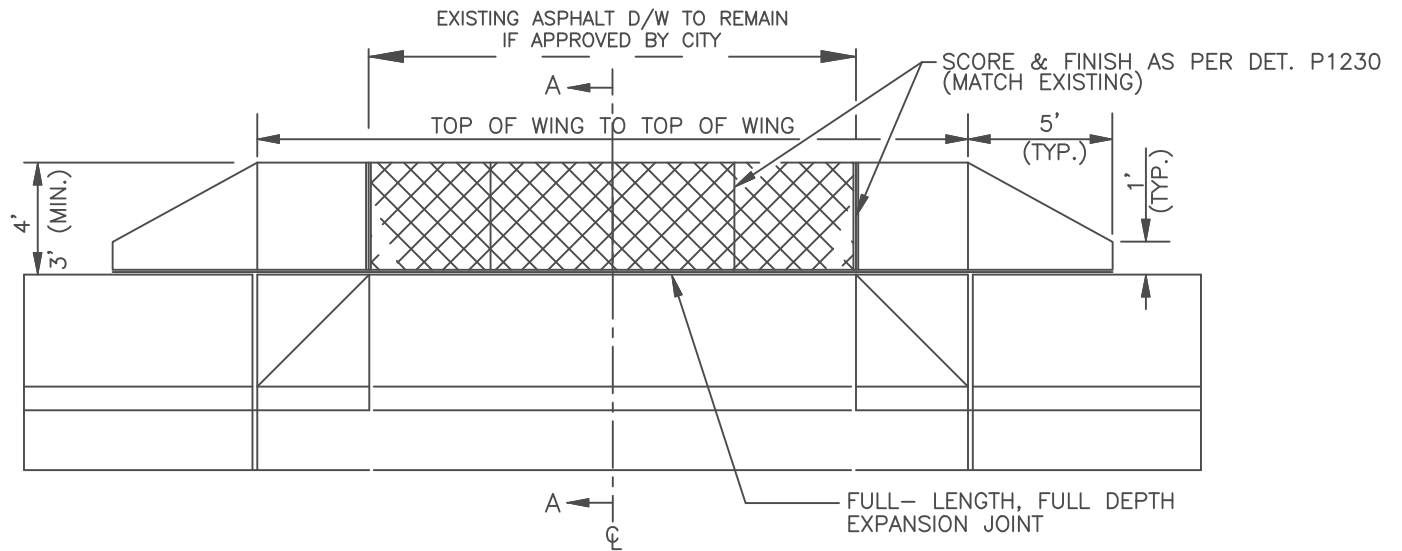
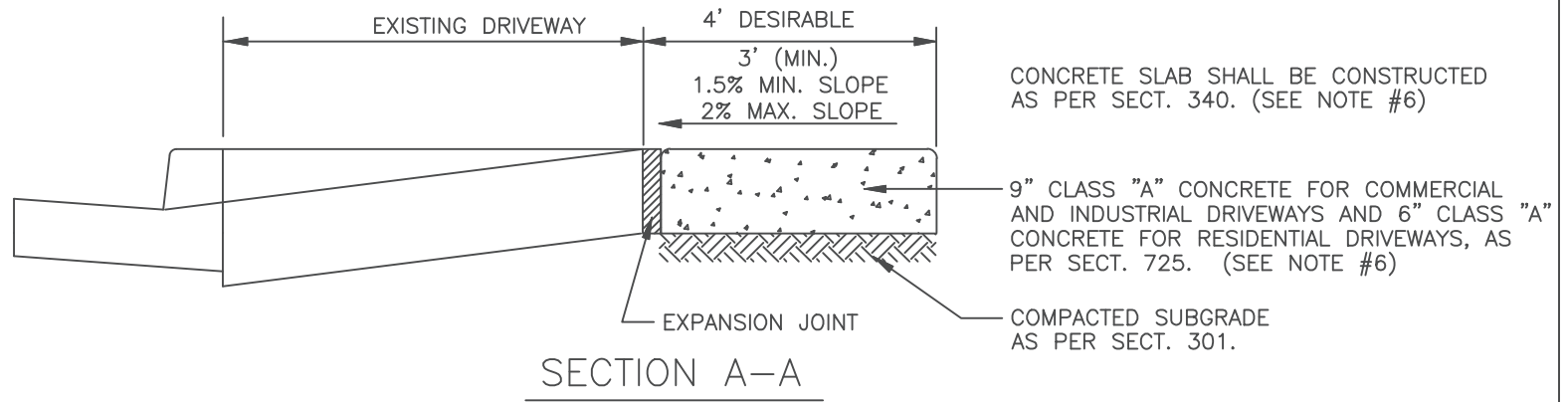

**NOTES**

1. EXPANSION JOINT FILLER SHALL BE 1/2" BITUMINOUS TYPE PREFORMED EXPANSION JOINT FILLER, A.S.T.M. D-1751.
2. CONTROL & EXPANSION JOINTS SHALL ALIGN WITH EXISTING JOINTS IN DRIVEWAY.
3. CONCRETE SHALL BE CLASS "A", SECT. 725.
4. EXPANSION JOINT MATERIAL SHALL BE SECURED IN PLACE PRIOR TO POURING CONCRETE AND SHALL COMPLETELY SEPARATE THE DRIVEWAY SLAB FROM THE SIDEWALK, EXTENDING FROM THE SURFACE TO THE SUBGRADE.
5. EXPANSION JOINT MATERIAL SHALL BE USED WHEN NEW POURING IS ADJACENT TO EXISTING DRIVEWAY AREA.
6. INDICATES AREA WHICH MAY REMAIN ASPHALT IF THE CROSS SLOPE & PAVING CONDITIONS MEET ADA STANDARDS.

# DRIVEWAY WIDTHS POLICY

STREET CLASSIFICATION	TYPE OF DEVELOPMENT					
	SINGLE FAMILY	MultiFamily/Commercial		GAS STATION	TRUCK FACILITIES	GATES
		<30 spaces	>30 spaces			
ALLEY	16' MINIMUM	20'	20'	<del>                    </del>	<del>                    </del>	<del>                    </del>
LOCAL RESIDENTIAL	12' ONE CAR 16' ONE CAR – RECOMMENDED	24' – 30'	30'	<del>                    </del>	<del>                    </del>	**
LOCAL COMMERCIAL/INDUSTRIAL	<del>                    </del>	30' – 40' ***	30' – 40' ***	40' ***	40' – 50' ***	**
COLLECTOR RESIDENTIAL	16' MINIMUM	30' ***	30' ***	40' ***	<del>                    </del>	**
COLLECTOR COMMERCIAL/INDUSTRIAL	<del>                    </del>	30' – 40' ***	30' – 50' ***	40' – 50' ***	40' – 50' ***	**
ARTERIAL	DISCOURAGED EXCEPT FOR LARGE LOT-CIRCULAR DRIVES *	30' ***	40' ***	40' – 50' ***	40' – 50' ***	**

- \* MINIMUM 82' PROPERTY WIDTH
- \*\* SEE GATE ACCESS TURNAROUND HANDOUT – DSD
- \*\*\* MEDIAN –30' MAXIMUM UNLESS THERE IS SIGNIFICANT TRUCK ACCESS – THEN 40'

Local/Collector One Way		Arterial One Way	
In	Out	In	Out
24'	16'	24'	20'

- NOTES:
- 1) DRIVEWAYS GREATER THAN 50' ARE NOT PERMITTED BY CITY CODE UNLESS A WAIVER OF THE ORDINANCE IS OBTAINED FROM THE DRIVEWAY HEARING OFFICER OR HIS DESIGNEE.
  - 2) DEVIATION FROM THIS POLICY CAN BE DETERMINED BY THE CITY OF PHOENIX TRAFFIC ENGINEER.



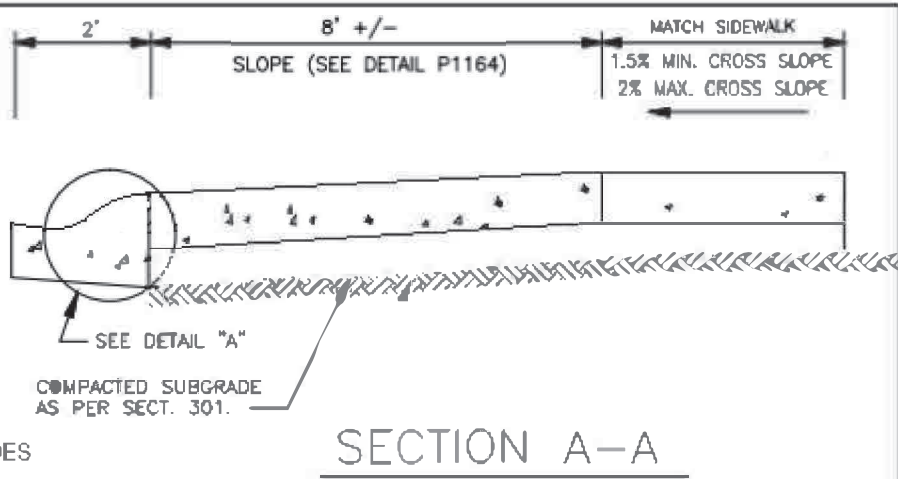
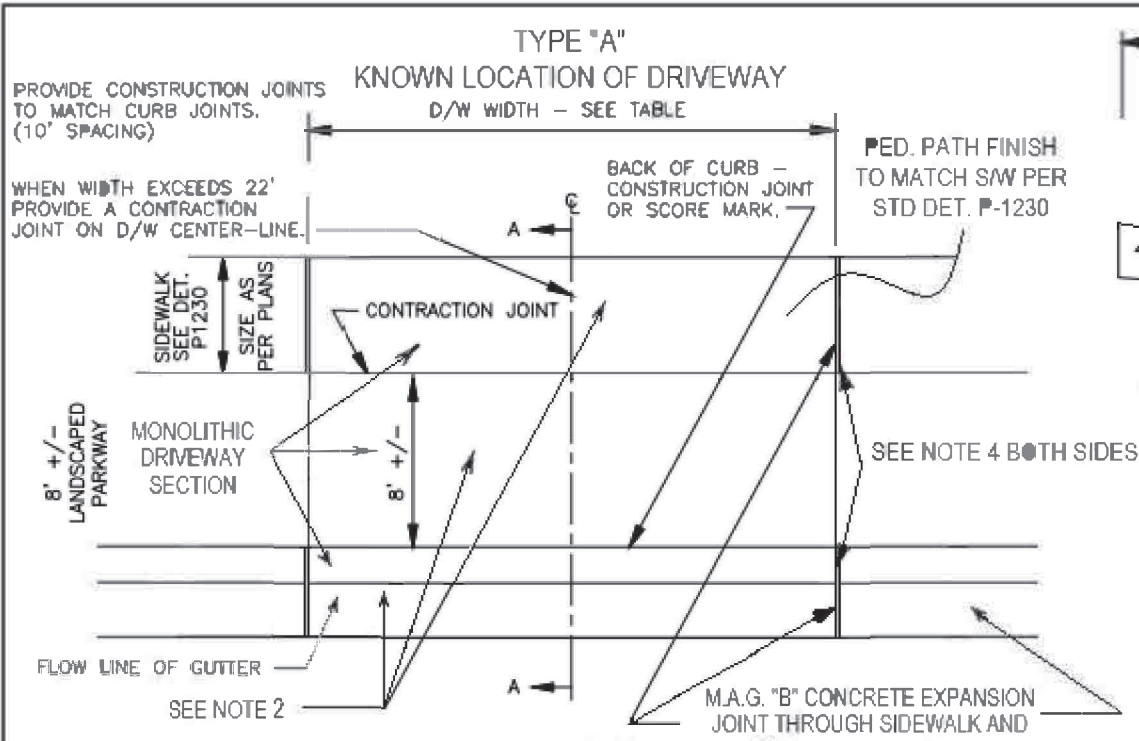

- #### NOTES
1. ALL DETACHED SIDEWALK THAT FRONTS ROLL CURB SHALL BE 6" M.A.G. "A" CONCRETE 8" CLASS "A" CONCRETE FOR COMMERCIAL AND INDUSTRIAL DRIVEWAYS AND 6" CLASS "A" CONCRETE FOR RESIDENTIAL DRIVEWAYS, AS PER SECT. 725.
  2. PAYMENT FOR DRIVEWAY SHALL BE ON A SQUARE FOOT BASIS.
  3. EXPANSION JOINT MATERIAL SHALL BE SECURED IN PLACE PRIOR TO POURING CONCRETE AND SHALL COMPLETELY SEPARATE THE DRIVEWAY SLAB FROM THE SIDEWALK, EXTENDING FROM THE SURFACE TO THE SUBGRADE.

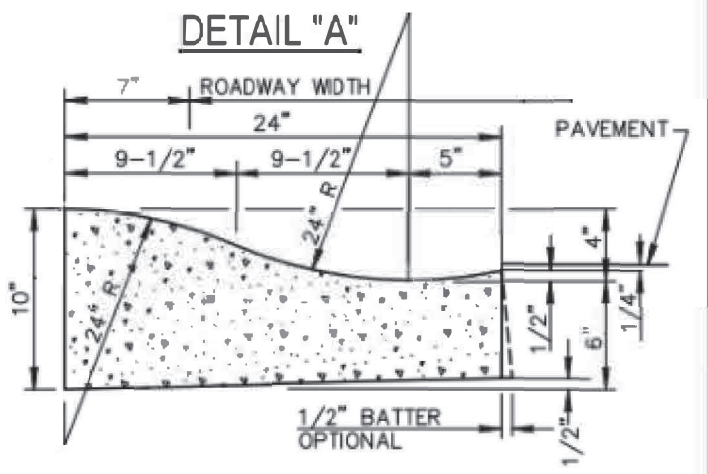
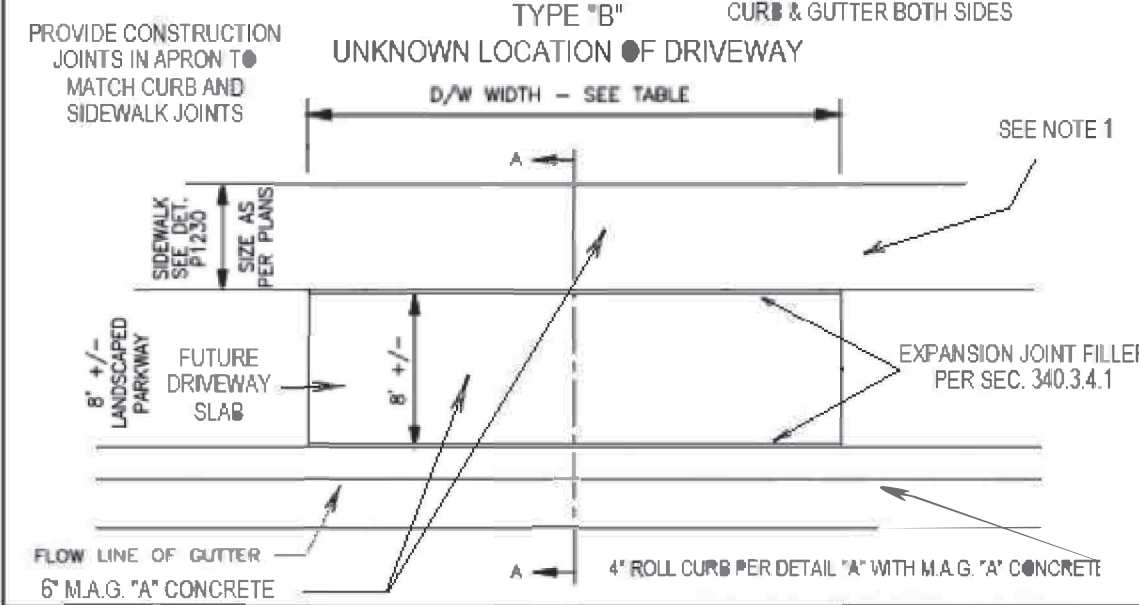

DIRECTION OF TRAVEL

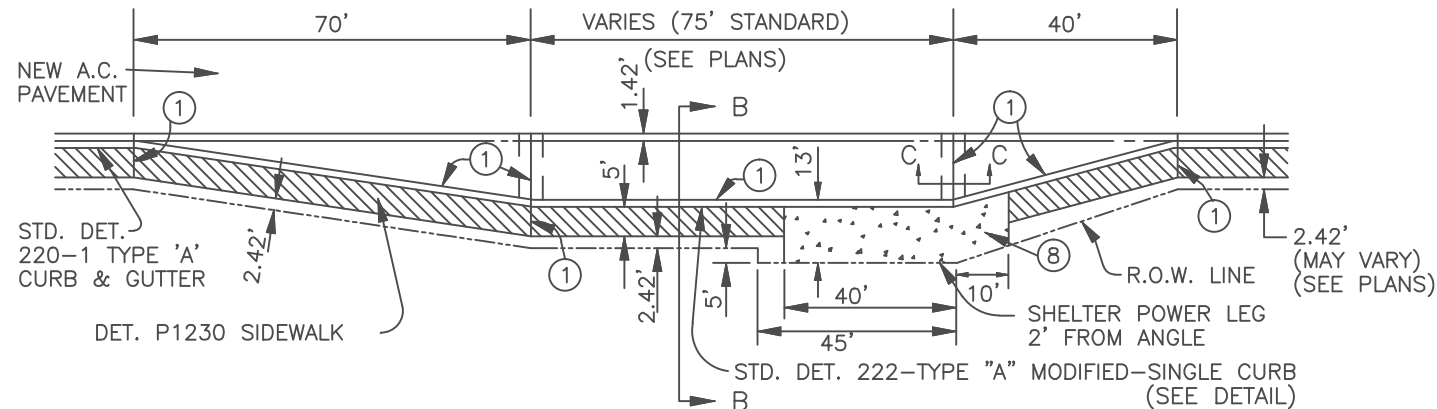

PLAN VIEW

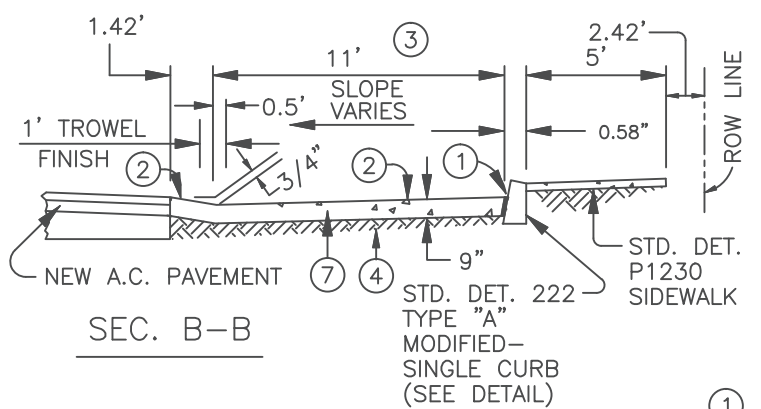

SEC. B-B

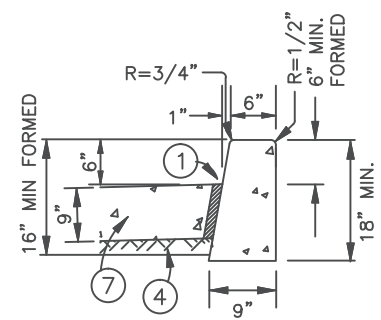

STD. DET. 222-TYPE "A"  
MOD. SINGLE CURB

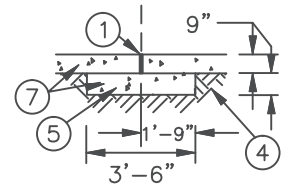

SEC. C-C

NOTES:

- ① 1/2" BITUMINOUS PREFORMED EXPANSION JOINT FILLER, A.S.T.M. D-1751
- ② CONCRETE BUS BAY PAVEMENT SHALL BE BROOM FINISHED, EXCEPT WHERE OTHERWISE NOTED.
- ③ MAY BE REDUCED TO 10' MINIMUM IF APPROVED BY CITY.
- ④ SUBGRADE PREPARATION PER SPECIFICATIONS.
- ⑤ CONCRETE PAD TO BE POURED SEPARATELY FROM CONCRETE BUS BAY PAVEMENT. (SEE SECTION C-C)
- ⑥ CONTRACTION JOINTS IN THE BUS BAY PAVEMENT SHALL MATCH THOSE IN THE CURB.
- ⑦ CONCRETE SHALL BE CLASS "A" PER M.A.G. SPECS. OR CLASS "S", F'C = 3000 PSI PER A.D.O.T. SPECS.
- ⑧ BUS SHELTER PAD, SEE DETAIL P1261
- ⑨ DRIVEWAYS SHALL NOT BE LOCATED WITHIN THE SHELTER PAD AREA.
- ⑩ CAN BE USED AT INTERSECTIONS WITH TOTAL ROADWAY WIDTHS OF 74' OR LARGER.

DIRECTION OF TRAVEL

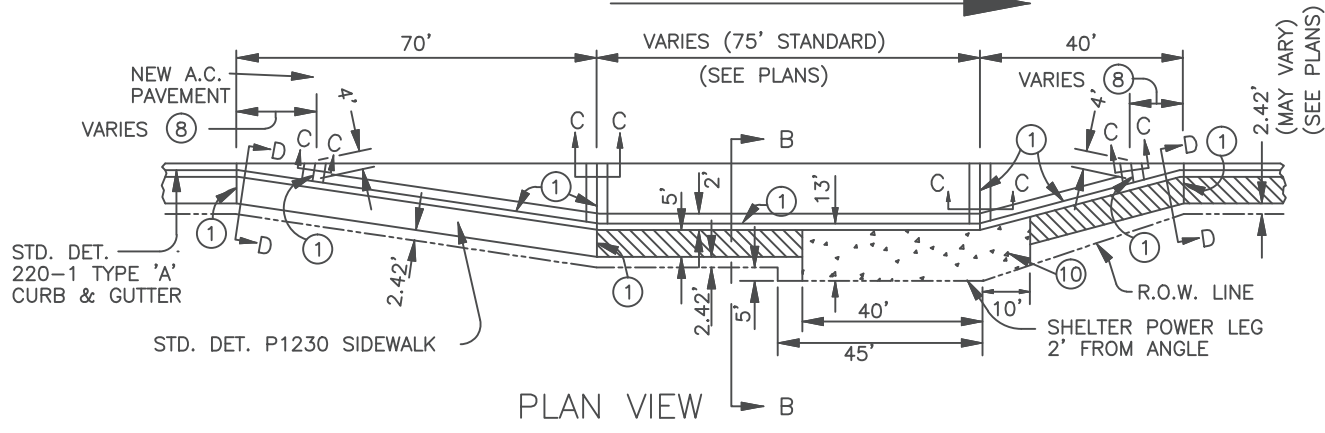

PLAN VIEW

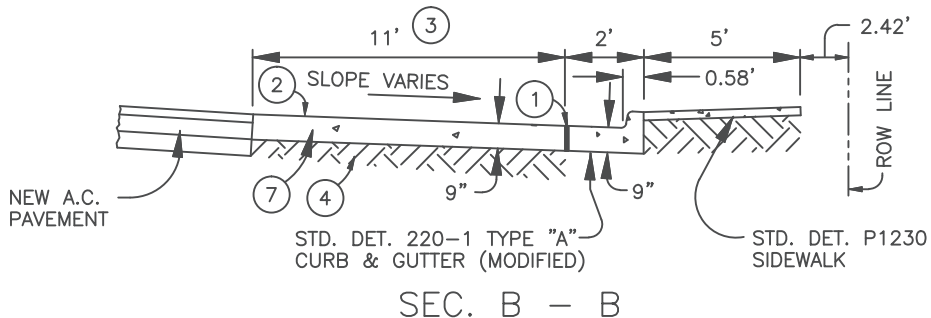

SEC. B - B

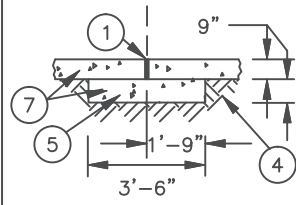

SEC. C - C

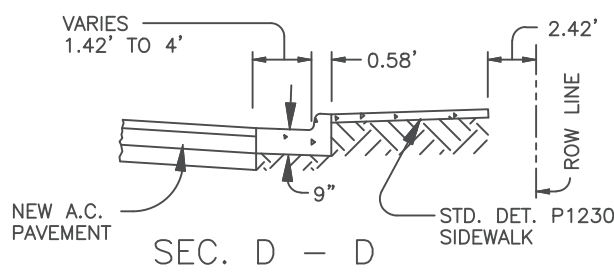

SEC. D - D

NOTES:

- ① 1/2" BITUMINOUS PREFORMED EXPANSION JOINT FILLER, A.S.T.M. D-1751
- ② CONCRETE BUS BAY PAVEMENT SHALL BE BROOM FINISHED.
- ③ MAY BE REDUCED TO 10' MINIMUM IF APPROVED BY CITY.
- ④ SUBGRADE PREPARATION PER SPECIFICATIONS.
- ⑤ CONCRETE PAD TO BE POURED SEPARATELY FROM CONCRETE BUS BAY PAVEMENT. (SEE SECTION C-C)
- ⑥ CONTRACTION JOINTS IN THE BUS BAY PAVEMENT SHALL MATCH THOSE IN THE CURB.
- ⑦ CONCRETE SHALL BE CLASS "A" PER M.A.G. SPECS. OR CLASS "S", F'C = 3000 PSI PER A.D.O.T. SPECS.
- ⑧ CURB & GUTTER-TO-BUS BAY PAVEMENT-TRANSITION (LENGTH VARIES)
- ⑨ DRIVEWAYS SHALL NOT BE LOCATED WITHIN THE SHELTER PAD AREA.
- ⑩ BUS SHELTER PAD, SEE DETAIL P1261
- ⑪ CAN BE USED AT INTERSECTIONS WITH TOTAL ROADWAY WIDTHS OF 74' OR LARGER.

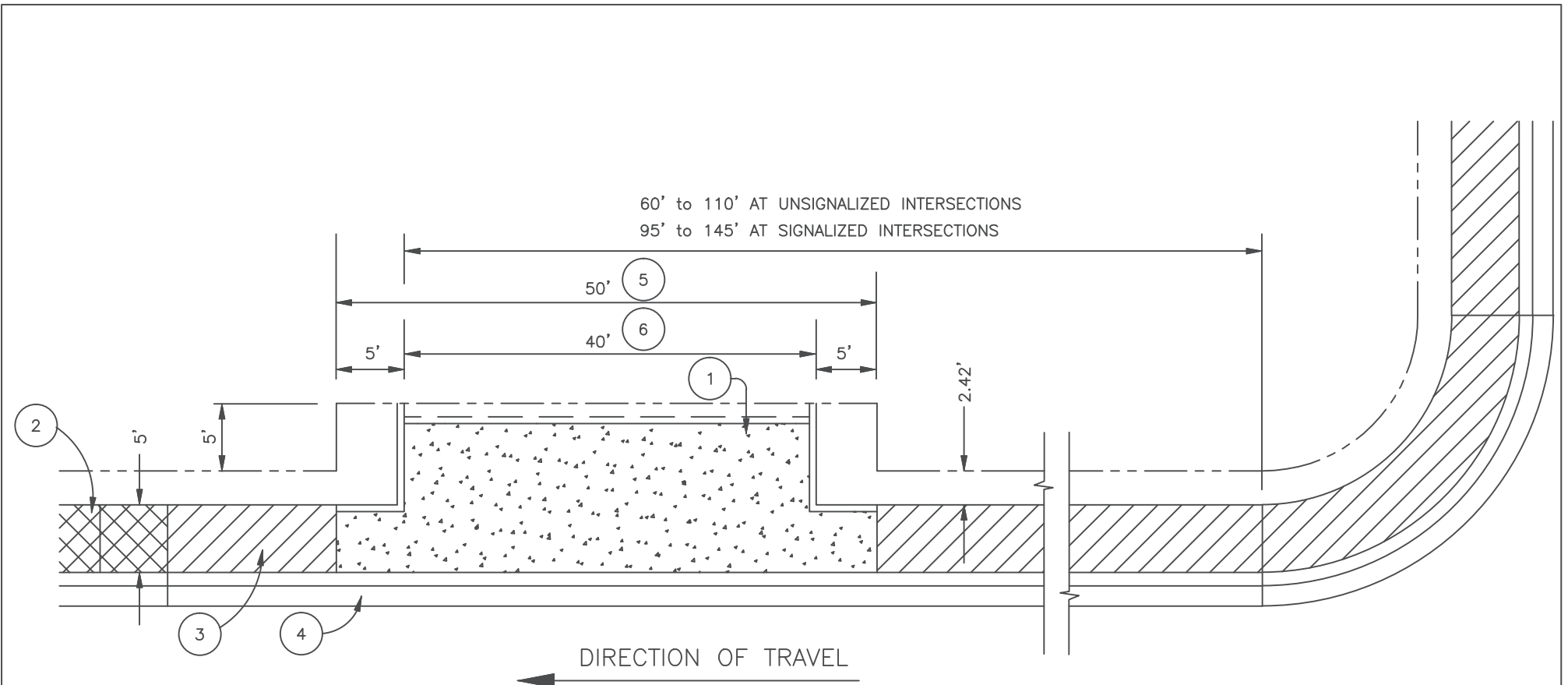

- (1) BUS SHELTER PAD.  
SEE DETAIL P1260 OR P1262
- (2) DRIVEWAYS SHALL NOT BE  
LOCATED WITHIN THE SHELTER  
PAD AREA.
- (3) SIDEWALK DETAIL P1230

- (4) CURB & GUTTER DETAIL 220-1  
TYPE "A".
- (5) REDUCE TO 30' IN  
SINGLE FAMILY RESIDENTIAL  
AREAS.
- (6) REDUCE TO 20' IN  
SINGLE-FAMILY RESIDENTIAL  
AREAS.

INSTALL 3/4" CONDUIT FROM JUNCTION BOX TO JUNCTION BOX PRIOR TO PLACEMENT OF CONCRETE.

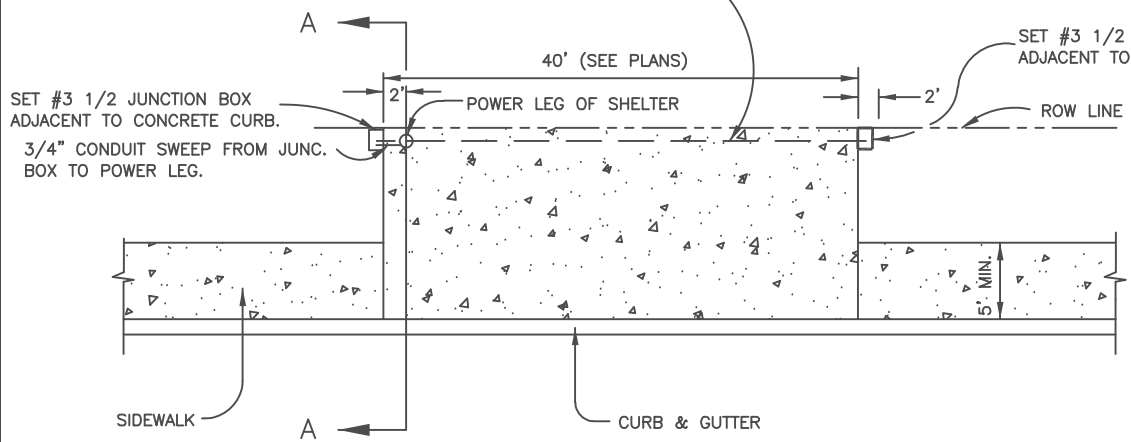

PLAN VIEW

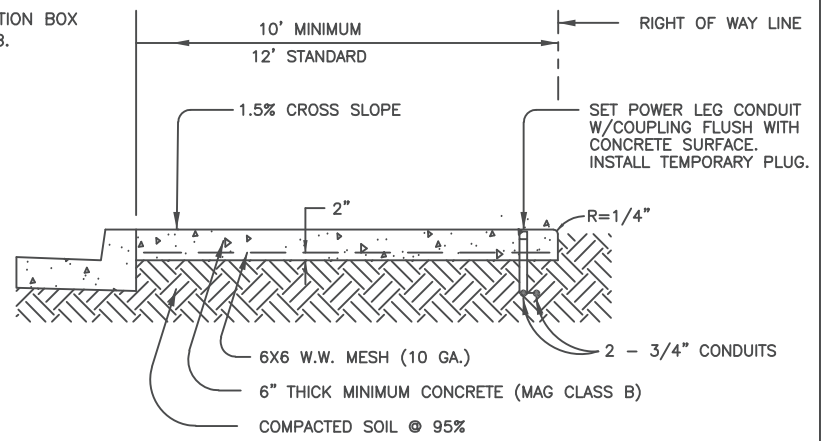

SECTION A - A

**NOTES:**

1. ACTUAL PLAN LAYOUT MAY VARY. ALL OTHER DETAIL INFORMATION REMAINS THE SAME. SEE PLANS FOR SPECIFIC LOCATIONS AND DIMENSIONS OF BUS SHELTER PAD.
2. ANY SHELTER OR BUS STOP FURNITURE PLACEMENT SHALL BE LOCATED TO PROVIDE A MIN. 5 ft. WIDE CLEAR SIDEWALK.
3. DECORATIVE PAVEMENT OPTIONS MAY INCLUDE EXPOSED AGGREGATE 1/4" (NO LARGER) WITH DESIGN STRENGTH OF 4000 PSI MINIMUM. OTHER OPTIONS INCLUDING COLOR (TO MATCH SURROUNDINGS) AND STAMPING WILL BE CONSIDERED. CONCRETE MIX DESIGN THROUGH THE CITY OF PHOENIX MATERIALS LAB. DECORATIVE OPTIONS TO BE APPROVED BY THE CITY OF PHOENIX. PAVERS ARE NOT TO BE USED.
4. ELECTRICAL CONDUITS AND JUNCTION BOXES SHALL NOT BE REQUIRED UNLESS REQUESTED PER CITY OF PHOENIX.
5. ALL CONDUIT SHALL BE P.V.C. SCHEDULE 40, U.L. LISTED.
6. ALL COSTS ASSOCIATED WITH ELECTRICAL AND RELATED ITEMS SHOWN ON THESE DETAILS (CONDUITS, JUNCTION BOXES, GROUND ROD, ETC.) SHALL BE CONSIDERED INCLUDED IN THE COST OF THE PAY ITEM FOR CONCRETE BUS SHELTER PAD.
7. BUS BAY PAVEMENT, CONCRETE PAD, CONCRETE CURB, SINGLE CURB, CURB & GUTTER, SIDEWALKS, & DRIVEWAYS ARE SEPARATE PAY ITEMS.
8. SHELTER PADS AND DRIVEWAYS SHALL BE LOCATED TO PROVIDE MINIMUM INTERSECTION SIGHT DISTANCE IN ACCORDANCE WITH CURRENT AASHTO STANDARDS (CASE IIIA).
9. MAG CLASS A CONCRETE MAY BE SUBSTITUTED FOR MAG CLASS B CONCRETE WITH 6X6 MESH

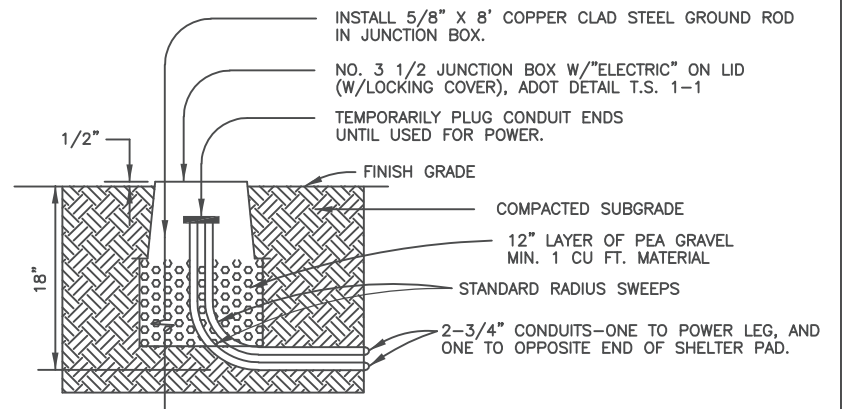

SLEEVE SWEEP & JUNCTION BOX DETAIL

REINFORCED CONCRETE PAD  
SEE DETAILS

POWER LEG OF SHELTER

3/4" CONDUIT SWEEP FROM  
JUNCTION BOX TO POWER LEG

SET JUNCTION BOX  
ADJACENT TO PAD

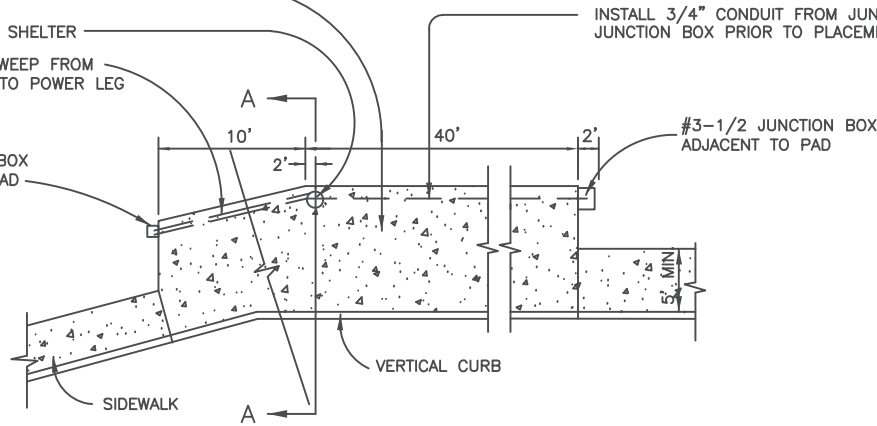

PLAN VIEW

INSTALL 3/4" CONDUIT FROM JUNCTION BOX TO  
JUNCTION BOX PRIOR TO PLACEMENT OF CONCRETE

#3-1/2 JUNCTION BOX  
ADJACENT TO PAD

VERTICAL CURB

SIDEWALK

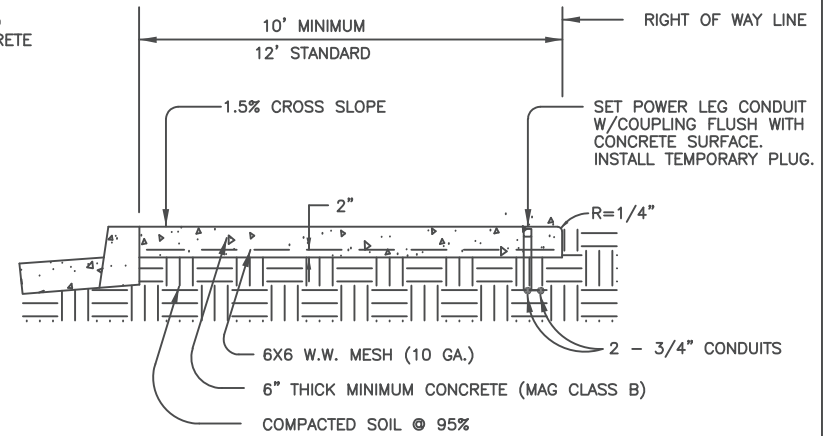

SECTION A - A

NOTES:

1. ACTUAL PLAN LAYOUT MAY VARY. ALL OTHER DETAIL INFORMATION REMAINS THE SAME. SEE PLANS FOR SPECIFIC LOCATIONS AND DIMENSIONS OF BUS SHELTER PAD.
2. ANY SHELTER OR BUS STOP FURNITURE PLACEMENT SHALL BE LOCATED TO PROVIDE A MIN. 5 FT. WIDE CLEAR SIDEWALK.
3. DECORATIVE PAVEMENT OPTIONS MAY INCLUDE EXPOSED AGGREGATE 1/4" (NO LARGER) WITH DESIGN STRENGTH OF 4000 PSI MINIMUM. OTHER OPTIONS INCLUDING COLOR (TO MATCH SURROUNDINGS) AND STAMPING WILL BE CONSIDERED. CONCRETE MIX DESIGN THROUGH THE CITY OF PHOENIX MATERIALS LAB. DECORATIVE OPTIONS TO BE APPROVED BY THE CITY OF PHOENIX. PAVERS ARE NOT TO BE USED.
4. ELECTRICAL CONDUITS AND JUNCTION BOXES SHALL NOT BE REQUIRED UNLESS REQUESTED PER CITY OF PHOENIX.
5. ALL CONDUIT SHALL BE P.V.C. SCHEDULE 40, U.L. LISTED.
6. ALL COSTS ASSOCIATED WITH ELECTRICAL AND RELATED ITEMS SHOWN ON THESE DETAILS (CONDUITS, JUNCTION BOXES, GROUND ROD, ETC.) SHALL BE CONSIDERED INCLUDED IN THE COST OF THE PAY ITEM FOR CONCRETE BUS SHELTER PAD.
7. BUS BAY PAVEMENT, CONCRETE PAD, CONCRETE CURB, SINGLE CURB, CURB & GUTTER, SIDEWALKS, & DRIVEWAYS ARE SEPARATE PAY ITEMS.
8. SHELTER PADS AND DRIVEWAYS SHALL BE LOCATED TO PROVIDE MINIMUM INTERSECTION SIGHT DISTANCE IN ACCORDANCE WITH CURRENT AASHTO STANDARDS (CASE IIIA).
9. MAG CLASS A CONCRETE MAY BE SUBSTITUTED FOR MAG CLASS B CONCRETE WITH 6X6 MESH

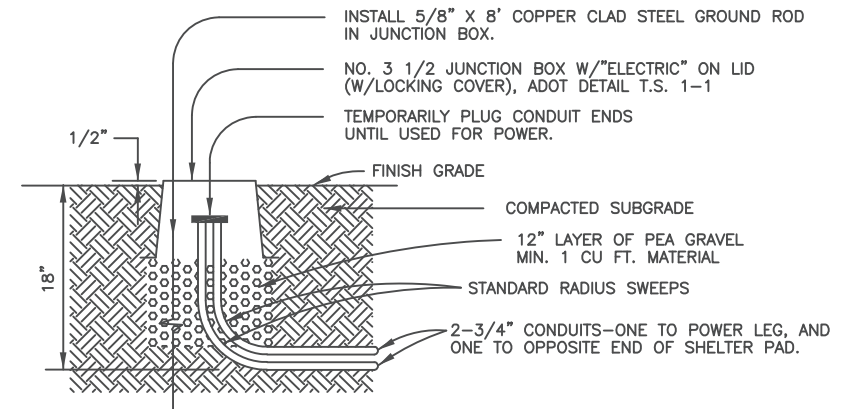

SLEEVE SWEEP & JUNCTION BOX DETAIL

DETAIL NO.  
P1261



**City of Phoenix**  
**STANDARD DETAIL**

BUS SHELTER/ACCESSORY PAD  
BUS BAY

APPROVED

*Eve Adams*  
CITY ENGINEER

04/01/2022  
DATE

DETAIL NO.  
P1261

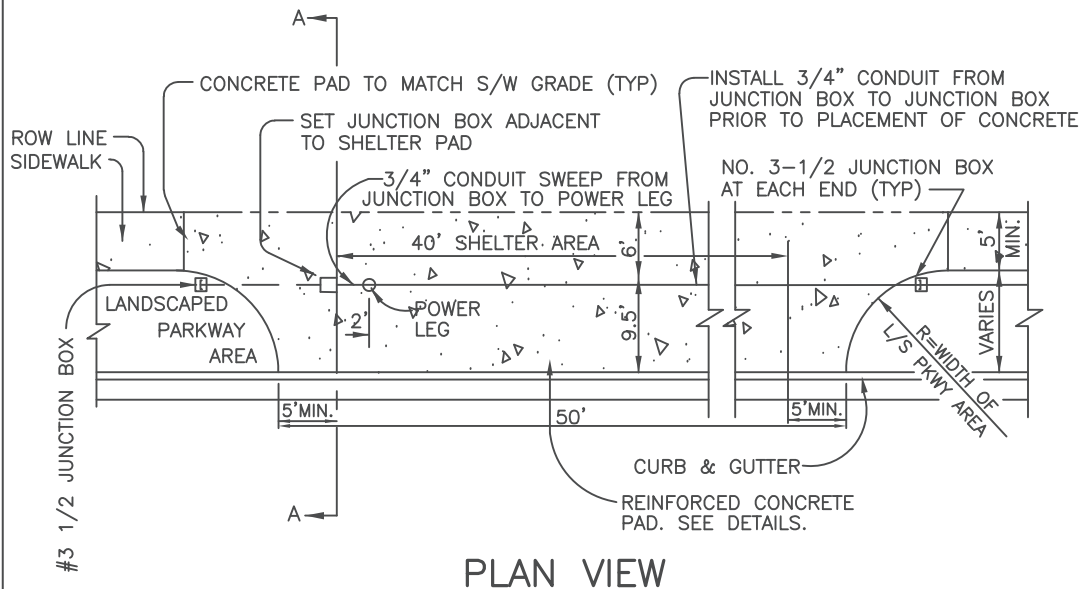

PLAN VIEW

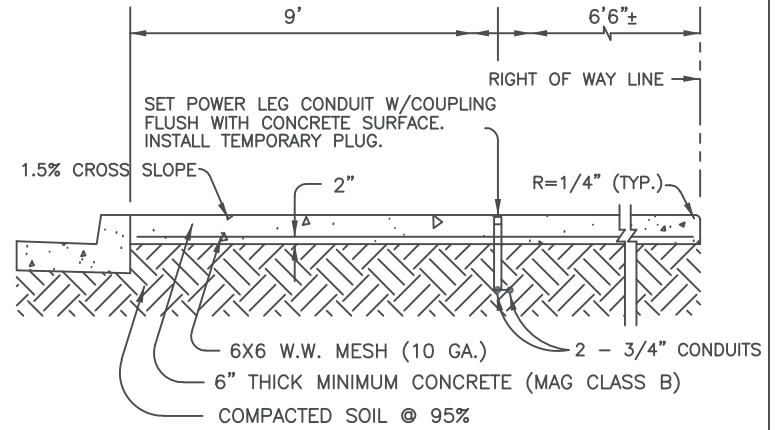

SECTION A - A

NOTES:

1. ACTUAL PLAN LAYOUT MAY VARY. ALL OTHER DETAIL INFORMATION REMAINS THE SAME. SEE PLANS FOR SPECIFIC LOCATIONS AND DIMENSIONS OF BUS SHELTER PAD.
2. ANY SHELTER OR BUS STOP FURNITURE PLACEMENT SHALL BE LOCATED TO PROVIDE A MIN. 5 ft. WIDE CLEAR SIDEWALK.
3. DECORATIVE PAVEMENT OPTIONS MAY INCLUDE EXPOSED AGGREGATE 1/4" (NO LARGER) WITH DESIGN STRENGTH OF 4000 PSI MINIMUM. OTHER OPTIONS INCLUDING COLOR (TO MATCH SURROUNDINGS) AND STAMPING WILL BE CONSIDERED. CONCRETE MIX DESIGN THROUGH THE CITY OF PHOENIX MATERIALS LAB. DECORATIVE OPTIONS TO BE APPROVED BY THE CITY OF PHOENIX. PAVERS ARE NOT TO BE USED.
4. ELECTRICAL CONDUITS AND JUNCTION BOXES SHALL NOT BE REQUIRED UNLESS REQUESTED PER CITY OF PHOENIX.
5. ALL CONDUIT SHALL BE P.V.C. SCHEDULE 40, U.L. LISTED.
6. ALL COSTS ASSOCIATED WITH ELECTRICAL AND RELATED ITEMS SHOWN ON THESE DETAILS (CONDUITS, JUNCTION BOXES, GROUND ROD, ETC.) SHALL BE CONSIDERED INCLUDED IN THE COST OF THE PAY ITEM FOR CONCRETE BUS SHELTER PAD.
7. BUS BAY PAVEMENT, CONCRETE PAD, CONCRETE CURB, SINGLE CURB, CURB & GUTTER, SIDEWALKS, & DRIVEWAYS ARE SEPARATE PAY ITEMS.
8. SHELTER PADS AND DRIVEWAYS SHALL BE LOCATED TO PROVIDE MINIMUM INTERSECTION SIGHT DISTANCE IN ACCORDANCE WITH CURRENT AASHTO STANDARDS (CASE IIIA).
9. MAG CLASS A CONCRETE MAY BE SUBSTITUTED FOR MAG CLASS B CONCRETE WITH 6X6 MESH.

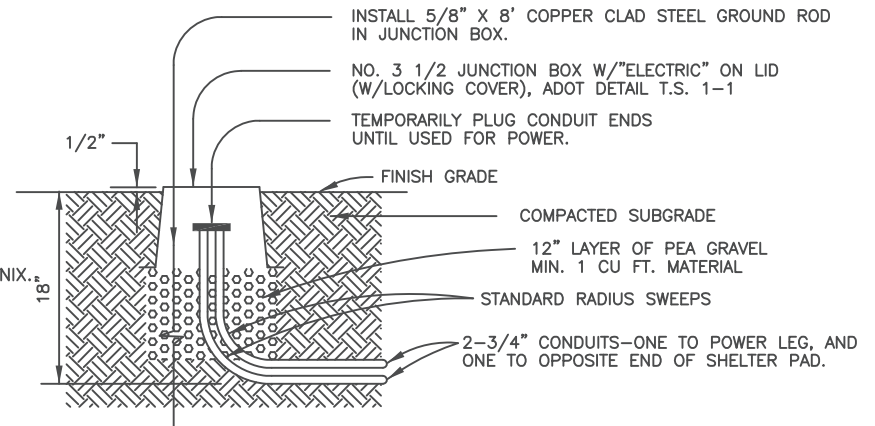

SLEEVE SWEEP & JUNCTION BOX DETAIL

DETAIL NO.  
P1262



PARKWAY BUS SHELTER/ACCESSORY PAD

APPROVED  
*Eve Hansen*  
CITY ENGINEER  
04/01/2022  
DATE

DETAIL NO.  
P1262

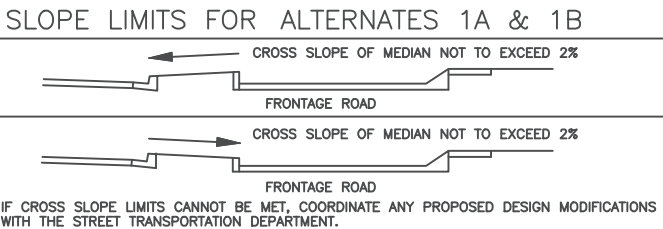
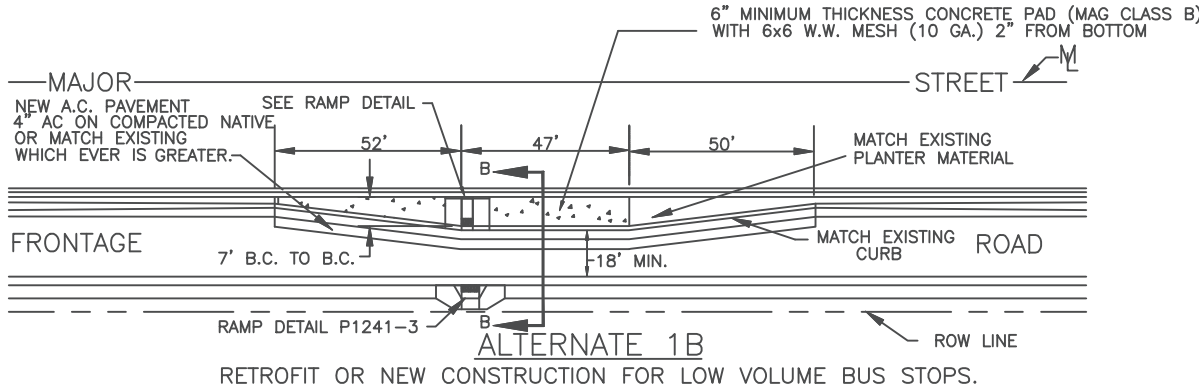
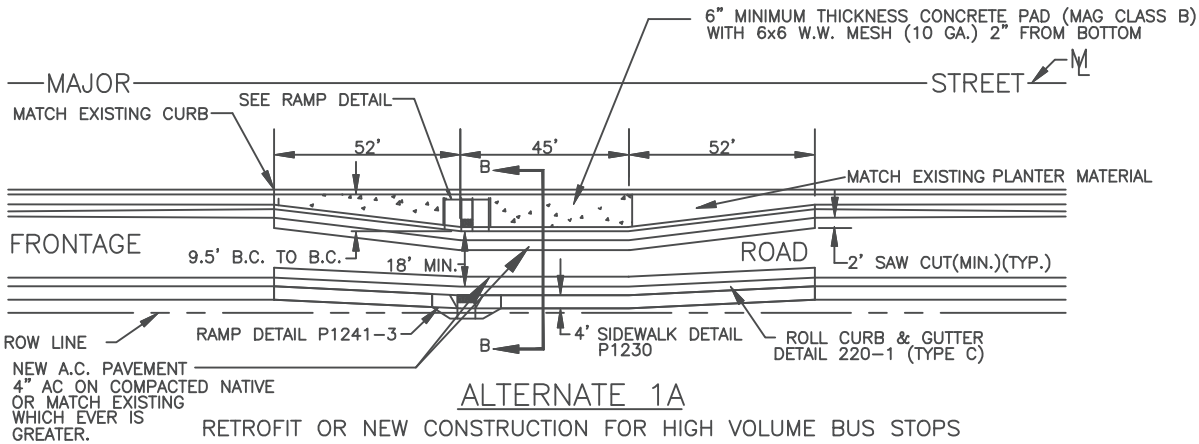

SECTION B-B

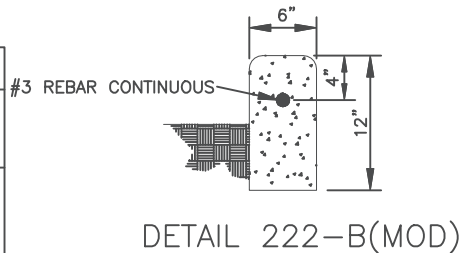

**NOTES:**

1. ALL DIMENSIONS ARE TO FACE OF CURB.
2. WHEEL CHAIR RAMP AND WING SLOPES SHALL NOT EXCEED 12:1.
3. COORDINATE REMOVAL OF LANDSCAPING WITH STREET TRANSPORTATION DEPARTMENT'S LANDSCAPE ARCHITECT.
4. EXISTING LANDSCAPE IRRIGATION LINES SHALL BE SLEEVED UNDER BUS SHELTER/ACCESSORY PAD & DECO PAVEMENT. SLEEVE SHALL EXTEND 12" BEYOND EACH SIDE OF PAVEMENT.
5. NOTIFY PARKS DEPARTMENT MAINTENANCE DISTRICT IF LANDSCAPE IRRIGATION SYSTEM WILL BE INTERRUPTED FOR MORE THAN 24 HOURS.
6. ALL CONCRETE AND ASPHALT REMOVALS SHALL BE SAW CUT. MIN. 2' ASPHALT REPLACEMENT ADJACENT TO NEW CURBS.
7. DECORATIVE PAVEMENT OPTIONS MAY INCLUDE EXPOSED AGGREGATE 1/4" (NO LARGER) WITH DESIGN STRENGTH 4000 PSI. OTHER OPTIONS INCLUDING COLOR (TO MATCH SURROUNDINGS) AND STAMPING WILL BE CONSIDERED. CONCRETE MIX DESIGN THROUGH THE CITY OF PHOENIX MATERIALS LAB. DECORATIVE OPTIONS TO BE APPROVED BY THE CITY OF PHOENIX. PAVERS ARE NOT TO BE USED.

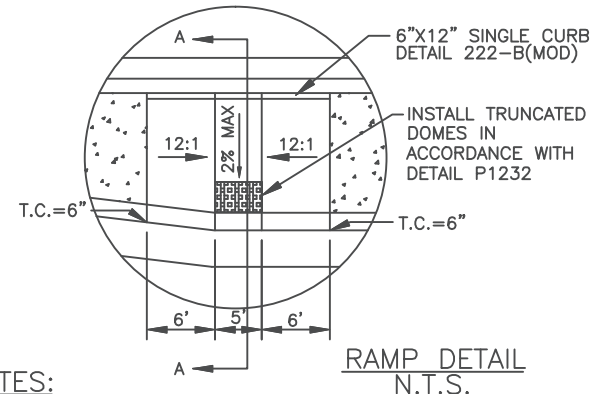

**NOTES:**

1. USE CLASS 'B' CONCRETE PER SECTION 725.
2. CONTROL ELEVATIONS SHOWN ARE IN RELATION TO THE GUTTER. GUTTER ELEVATION = 0.

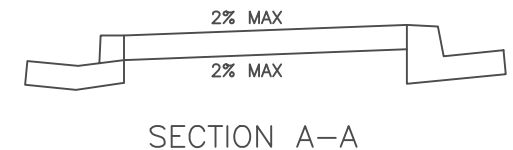



**NOTES:**

1. ALL DIMENSIONS ARE TO FACE OF CURB.
2. WHEEL CHAIR RAMP AND WING SLOPES SHALL NOT EXCEED 12:1.
3. COORDINATE REMOVAL OF LANDSCAPING WITH STREET TRANSPORTATION DEPARTMENT'S LANDSCAPE ARCHITECT.
4. EXISTING LANDSCAPE IRRIGATION LINES SHALL BE SLEEVED UNDER BUS SHELTER/ACCESSORY PAD. SLEEVE SHALL EXTEND 12" BEYOND EACH SIDE OF PAD.
5. NOTIFY PARKS DEPARTMENT MAINTENANCE DISTRICT IF LANDSCAPE IRRIGATION SYSTEM WILL BE INTERRUPTED FOR MORE THAN 24 HOURS.
6. ALL CONCRETE AND ASPHALT REMOVALS SHALL BE SAW CUT. MIN. 2' ASPHALT REPLACEMENT ADJACENT TO NEW CURBS.
7. SEE DETAIL P1263-1 FOR CROSS SLOPE LIMITS.
8. DECORATIVE PAVEMENT OPTIONS MAY INCLUDE EXPOSED AGGREGATE 1/4" (NO LARGER) WITH DESIGN STRENGTH OF 4000 PSI MINIMUM. OTHER OPTIONS INCLUDING COLOR (TO MATCH SURROUNDINGS) AND STAMPING WILL BE CONSIDERED. CONCRETE MIX DESIGN THROUGH THE CITY OF PHOENIX MATERIALS LAB. DECORATIVE OPTIONS TO BE APPROVED BY THE CITY OF PHOENIX. PAVERS ARE NOT TO BE USED.

6" MINIMUM THICKNESS CONCRETE PAD (MAG CLASS B) WITH 6x6 W.W. MESH (10 GA.) 2" FROM BOTTOM

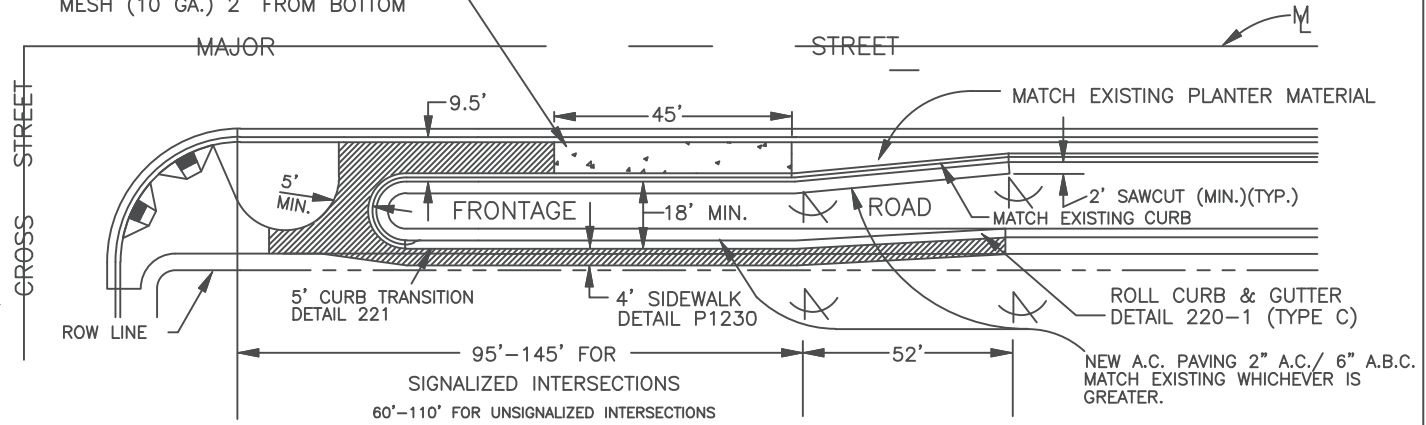

**ALTERNATE 2A**

NEW CONSTRUCTION FOR HIGH VOLUME BUS STOPS

6" MINIMUM THICKNESS CONCRETE PAD (MAG CLASS B) WITH 6x6 W.W. MESH (10 GA.) 2" FROM BOTTOM

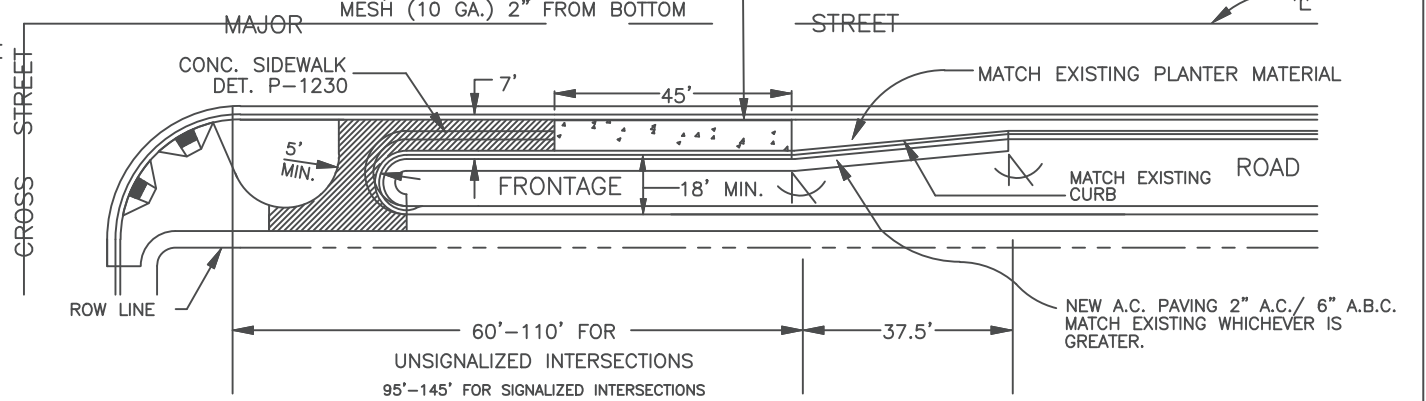

**ALTERNATE 2B**

RETROFIT OR NEW CONSTRUCTION FOR LOW VOLUME BUS STOPS.

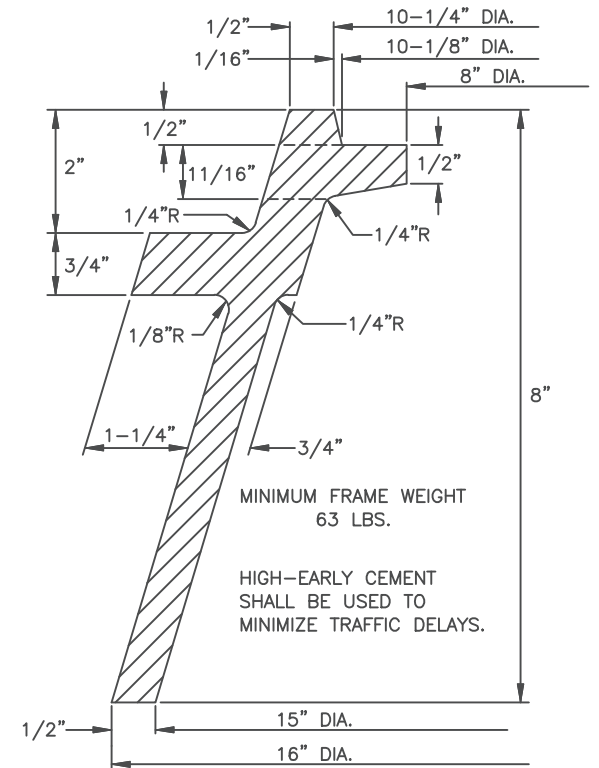
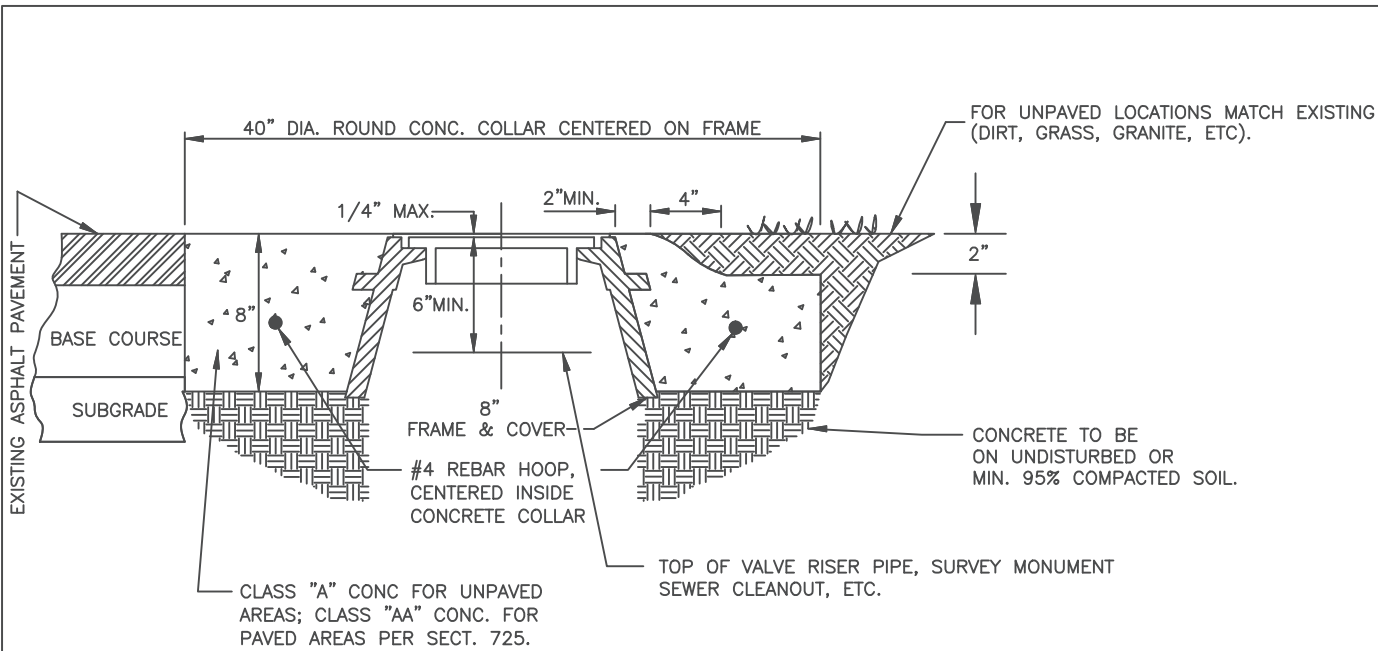

8" C.I. FRAME AND COVER

1) IN PAVED MAJOR ARTERIAL STREETS, CONCRETE COLLARS SHALL BE SCORED RADIALLY AT QUARTER-CIRCLE POINTS AND SCORES SHALL BE 1/4" WIDE BY 1/2" DEEP. CONCRETE SURFACE SHALL BE ROUGH BROOM FINISHED. NO TRAFFIC SHALL BE ALLOWED ON COLLARS UNTIL CONCRETE REACHES MINIMUM 2500 PSI ON ALL STREETS.

2) LETTERS ON COVER TO BE AS FOLLOWS: "SEWER", "WATER", OR "SURVEY" AS DIRECTED. TOTAL WIDTH OF WORD "SEWER" OR "WATER" 3-3/4". TOTAL WIDTH OF WORD "SURVEY" 4-1/2". LETTER SIZE 5/8" X 3/4", RAISED 1/16" ABOVE LEVEL OF COVER. TYPE OF LETTERS TO BE SUBMITTED FOR APPROVAL. CASTINGS TO CONFORM TO SECT. 787.

3) COMPACTION TO CONFORM TO SECT. 301 OR 601.

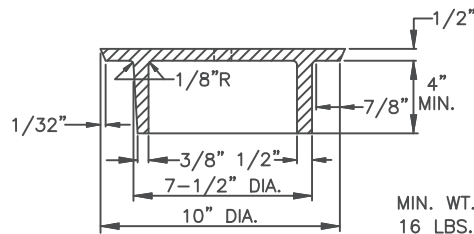

COVER SECTION A-A

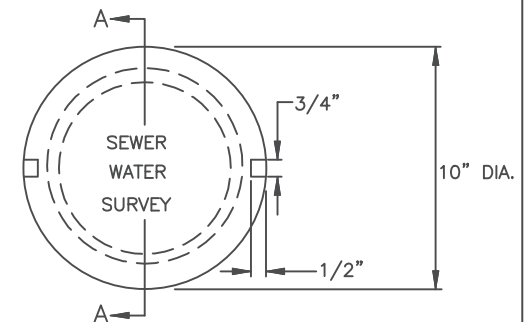

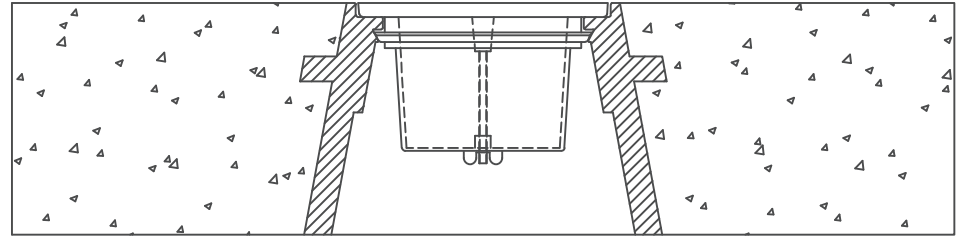
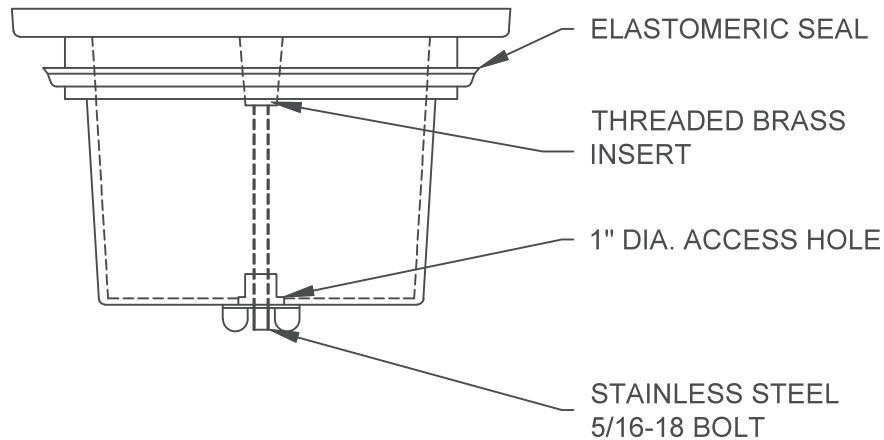

1. BODY OF THE SECURE VALVE BOX LID SHALL BE MOLDED USING AN ABS/POLYCARBONATE ALLOY, AND DISPLAY THE CITY OF PHOENIX LOGO, THE WORDS "CITY OF PHOENIX", AND "WATER".
2. WITH AN ELASTOMERIC SEAL WHICH WHEN PRESSED INTO PLACE BENEATH THE LID-SEAT, EXPANDS TO A DIAMETER GREATER THAN THE OPENING THROUGH WHICH IT WAS PASSED, BUT CAPABLE OF FOLDING BACK DURING LID EXTRACTION.
3. A HOLLOW ENCLOSURE MOLDED USING AN ABS/POLYCARBONATE ALLOY. CAPABLE OF BEING FILLED WITH A GRANULAR MATERIAL, FOR ADDITIONAL WEIGHT IF DESIRED, MUST BE AFFIXED BENEATH THE SURFACE PLATE OF LID, WITH SERIES 3400 STAINLESS STEEL 5/16"-18 BOLT INSERTED INTO THREADED BRASS INSERT MOLDED IN LID.
4. HOLLOW ENCLOSURE TO EXTEND A MINIMUM OF 4" BENEATH THE LID-SEAT, AND BE SECURED BY A STAINLESS STEEL BOLT EXTENDING THROUGH THE ENCLOSURE INTO THREADED BRASS INSERT IN LID.
5. HOLLOW ENCLOSURE MUST HAVE AN ACCESSIBLE OPENING OF AT LEAST 1" DIAMETER FOR FILLING, WHEN REQUIRED.
6. SECURE VALVE BOX LID TO BE AS MANUFACTURED BY SW SERVICES OR EQUAL.
7. SEE DETAIL P1391 FOR ADDITIONAL INFORMATION ON VALVE BOX INSTALLATIONS.

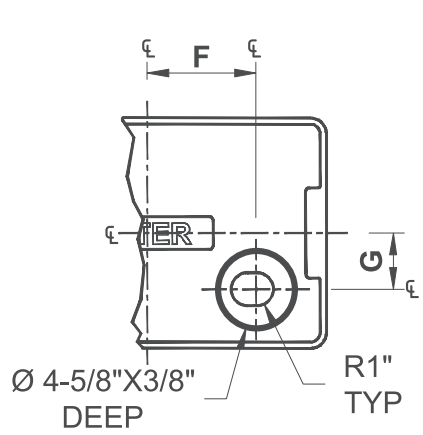
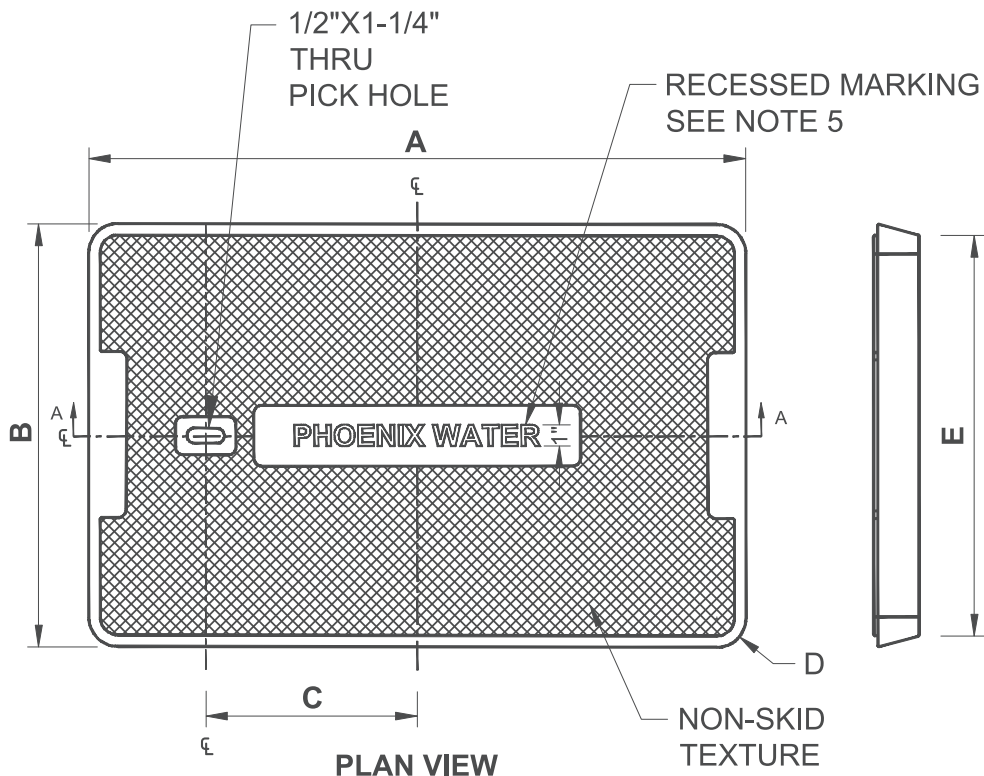

**NOTES:**

1. POTABLE WATER COVER TINTED GRAY AND RECLAIMED WATER COVER TINTED PANTONE PURPLE 512
2. DIMENSIONS SHOWN SHALL NOT VARY MORE THAN A 1/16 OF AN INCH
3. MUST BE CONSTRUCTED FROM ONE OF THE FOLLOWING MATERIALS: SHEET MOLDED COMPOUND (SMC), BULK MOLDED COMPOUND (BMC), OR POLYMER CONCRETE
4. SLOTTED AUTOMATIC METER READING (AMR) HOLE PER AGENCY OR STANDARD SPECIFICATION
5. LID SHALL BE STAMPED: PHOENIX WATER
6. REFER TO DETAIL P1320 FOR VERTICAL LOAD RATING

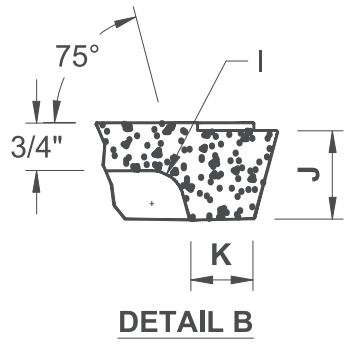
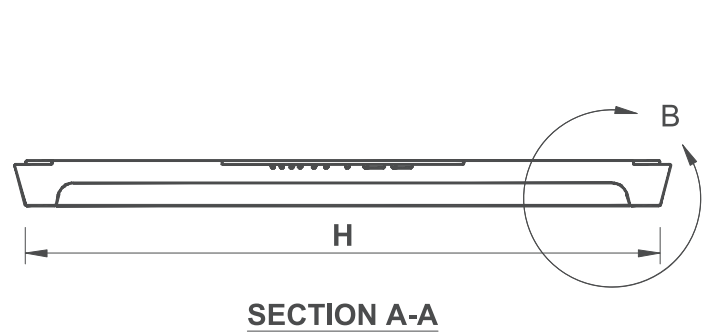

COVER DIMENSIONS		
DIMS	COVER NUMBER	
	2	4
A	21-7/8"	30-3/8"
B	14"	19-1/2"
C	7"	10"
D	1"	3/8"
E	13-1/4"	19"
F	6-5/8"	10-3/4"
G	3-3/8"	6-1/4"
H	21"	29-1/2"
I	1/2"	1/4"
J	1-1/2"	1-1/2"
K	1"	1"

DETAIL NO.  
P1315



**City of Phoenix**  
**STANDARD DETAIL**

WATER METER BOX COVER

APPROVED

*Eva...*  
CITY ENGINEER

12/13/2024  
DATE

DETAIL NO.  
P1315

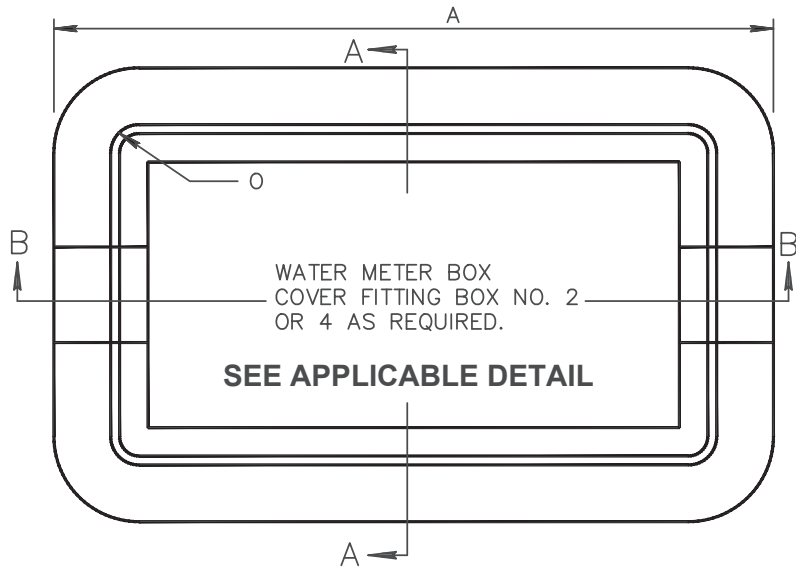

**PLAN VIEW**

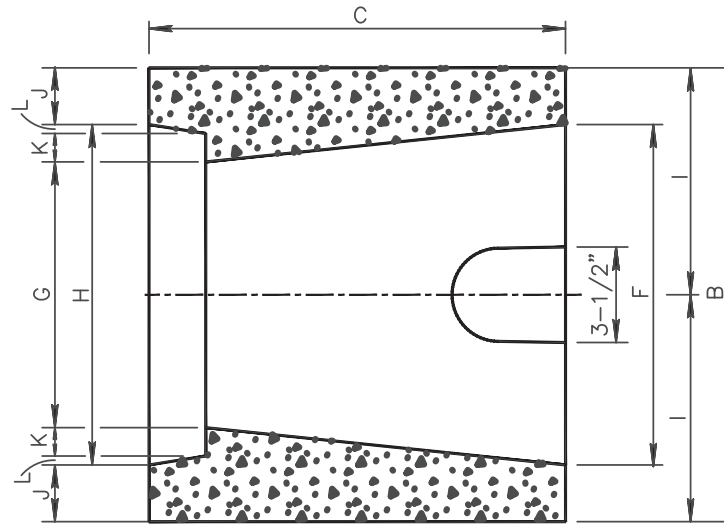

**SECTION A-A**

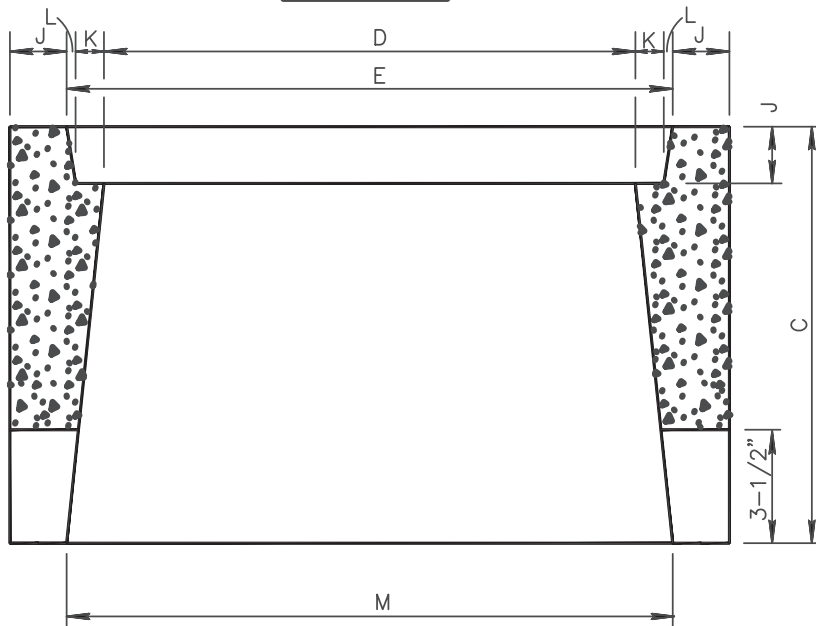

**SECTION B-B**

METER BOX DIMENSIONS		
DIMS	BOX NUMBER	
	2	4
A	25"	33-1/8"
B	17-1/4"	22-3/8"
C	12"	12"
D	20"	27-3/4"
E	22-1/8"	30-5/8"
F	14-1/2"	19-3/4"
G	12-1/2"	17"
H	14-1/4"	19-3/4"
I	8-5/8"	11-1/8"
J	1-1/2"	1-1/2"
K	1/2"	5/8"
L	1/2"	5/8"
M	21-7/8"	30-1/2"
O	1/2"	5/8"
	3/4" & 1" METERS	1-1/2" & 2" METERS

**NOTES:**

1. THE DIMENSIONS OF THE METER BOXES' LID SEATS (E & H) AS DEPICTED MAY NOT VARY MORE THAN 1/16 OF AN INCH
2. THE METER BOXES MUST BE CONSTRUCTED FROM ONE OF THE FOLLOWING MATERIALS: SHEET MOLDED COMPOUND (SMC), BULK MOLDED COMPOUND (BMC), OR POLYMER CONCRETE
3. MINIMUM VERTICAL LOAD RATING PER TIER 5 ANSI/SCTE77 TESTING STANDARD FOR GRADE LEVEL ENCLOSURES AND COVERS
4. FOR LOAD REQUIREMENTS ABOVE 5,000 POUNDS USE MAG DETAIL 319, TRAFFIC RATED BOX AND COVER
5. NUMBER 2 METER BOXES WILL BE USED FOR 3/4-INCH METERS AND 1-INCH METERS, AND NUMBER 4 BOXES WILL BE USED FOR 1-1/2-INCH METERS AND 2-INCH METERS



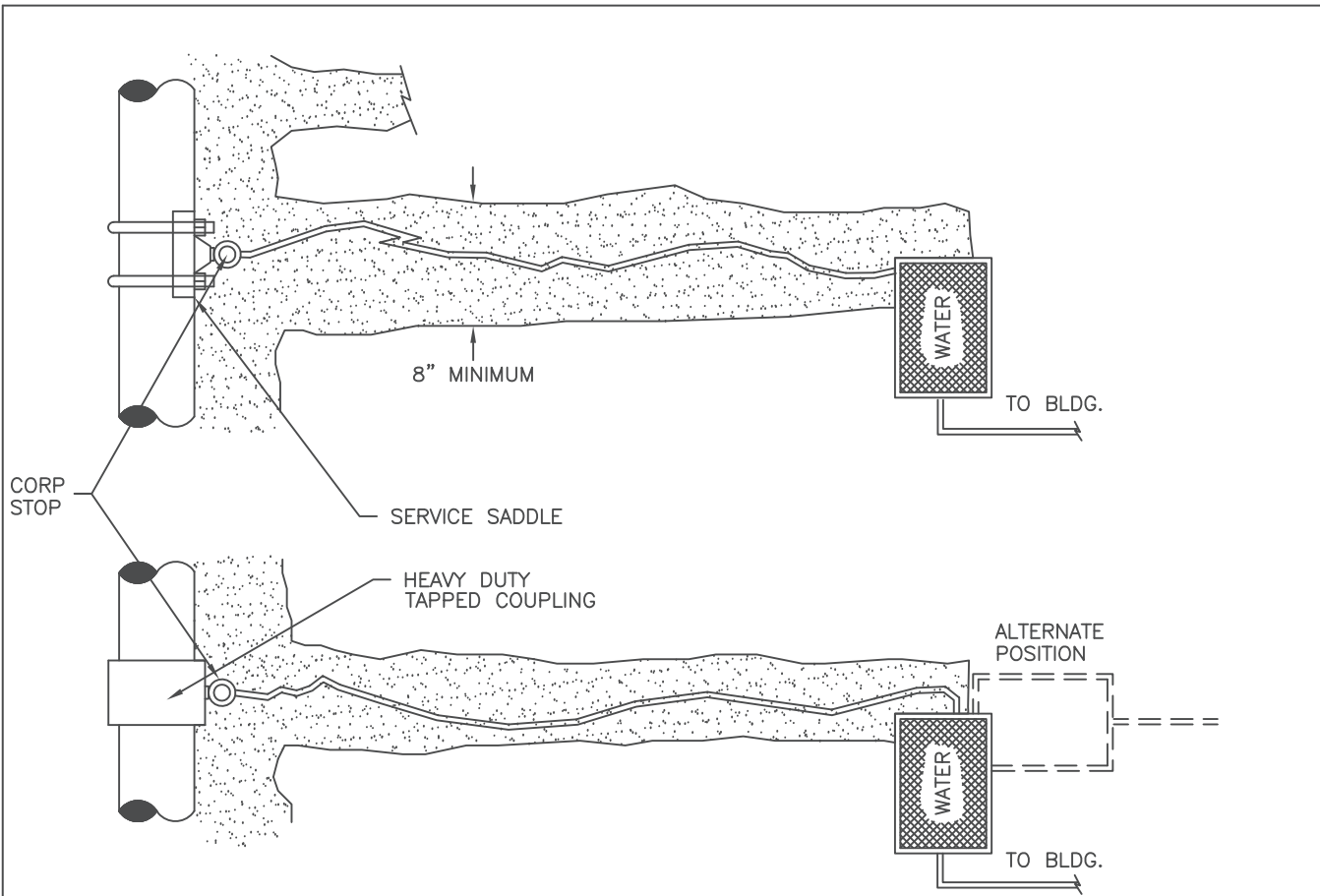

NOTES:

1. NEW WATER SERVICE TAPS SHALL BE INSTALLED USING AN ALL-BRONZE DOUBLE-STRAP TAPPING SADDLE OR A TAPPED COUPLING.
2. 30" MINIMUM COVER IS REQUIRED FOR SERVICE LINES.
3. WATER SERVICE INCLUDES THE CORP. STOP, SERVICE PIPE, APPURTENANT FITTINGS, CURB STOP, METER BOX & COVER. APPROVED WATER SERVICE COMPONENTS ARE LISTED IN CITY OF PHOENIX SUPPLEMENTS.
4. ONLY AUTHORIZED PERSONNEL OF THE WATER & WASTEWATER DEPT. SHALL INSTALL THE SERVICE CONNECTION FOR ANY EXISTING CITY WATER MAIN SERVING ALL OR PART OF A NEW SUBDIVISION.
5. WATER METER WILL BE INSTALLED BY CITY FORCES.
6. FOR 3/4" THROUGH 2" SERVICE USE COPPER PIPE.
7. FOR WATER METER LOCATION SEE CITY OF PHOENIX DETAIL P1363.
8. BALL VALVE SHALL BE: STRAIGHT THROUGH/FULL PORT DESIGN, MEET OR EXCEED 300PSIG PRESSURE RATING, NSF 61 & NSF 372 CERTIFIED, COMPLY WITH AWWA C-800

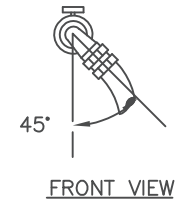
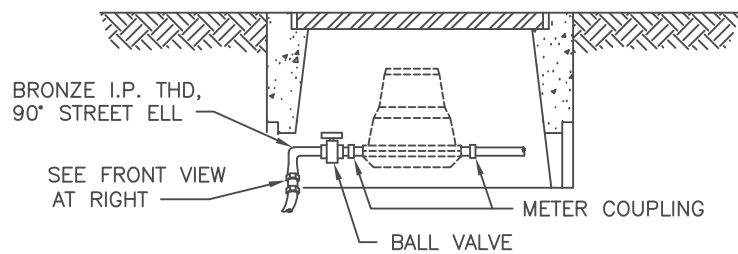
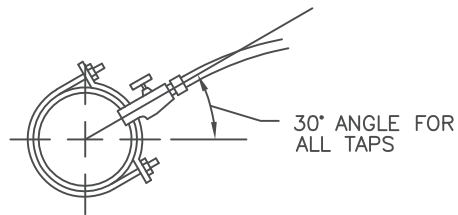

DETAIL NO.  
P1342



**City of Phoenix**  
**STANDARD DETAIL**

WATER SERVICE CONNECTIONS

APPROVED

*Eva...*  
CITY ENGINEER

04/01/2022  
DATE

DETAIL NO.  
P1342

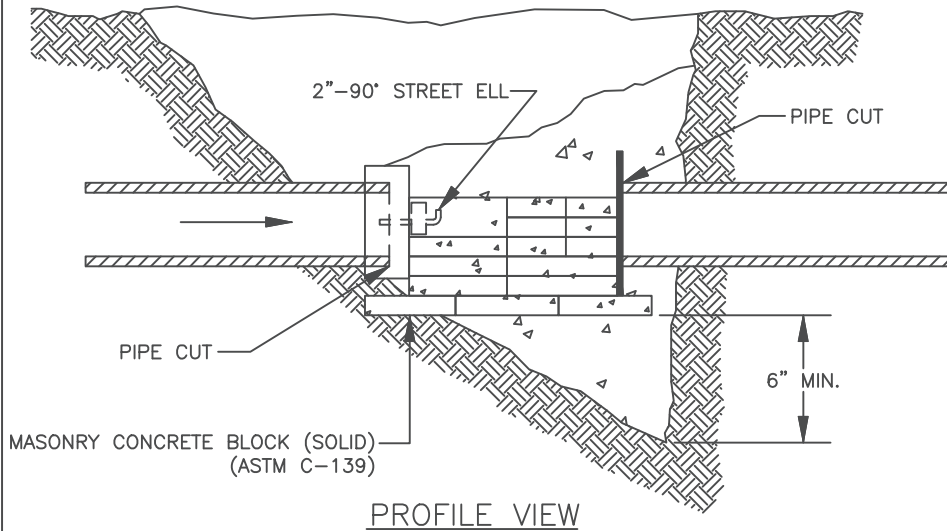
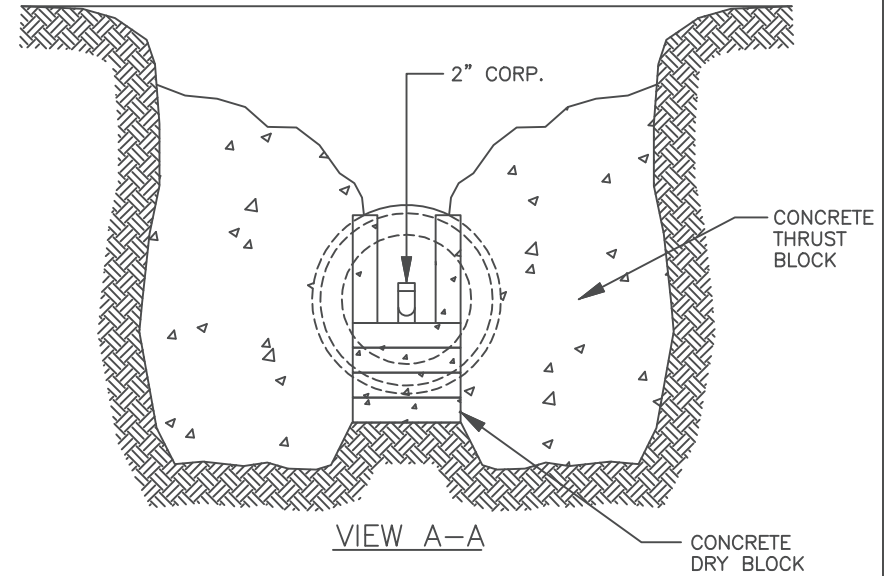
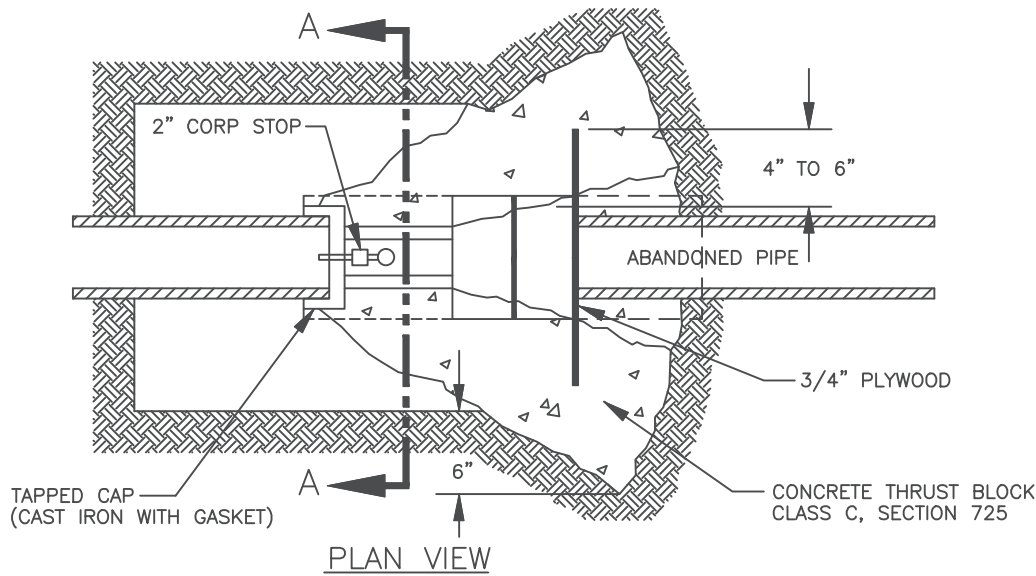

#### NOTES:

1. CUT AND PLUGS MUST BE ADEQUATELY "DRY BLOCKED".
2. DRY BLOCKS SHALL BE STANDARD SIZE SOLID MASONRY CONCRETE BLOCKS. (ASTM C-139)
3. THE QUANTITY AND ARRANGEMENT OF THE BLOCKING MUST WITHSTAND LINE PRESSURE BY HOLDING THE CAP OR PLUG IN POSITION.
4. DRY BLOCKING SHALL BE PROPERLY SHIMMED TIGHT AND SECURE AGAINST THE CAP BEFORE LINE PRESSURE IS RESTORED.
5. CONCRETE THRUST BLOCKS SHALL NOT BE POURED UNTIL LINE PRESSURE IS RESTORED AND THE CAP OR PLUG IS INSPECTED FOR LEAKAGE.
6. CONCRETE SHALL NOT BE POURED OVER ANY PORTION OF THE ABANDONED PIPE.
7. MINIMUM THRUST BLOCK AREA PER M.A.G. DETAIL 380.
8. WHERE A 4" OR LARGER LINE IS SPECIFIED TO BE ABANDONED, THE CUT AND PLUG SHOULD OCCUR AT THE SUPPLY MAIN TO AVOID CREATING AN UNUSED DEAD END LINE.

DETAIL NO.  
P1343



**City of Phoenix**  
**STANDARD DETAIL**

WATERLINE - CUT AND PLUG  
FOR 12" DIA. MAIN AND SMALLER

APPROVED

*Kenny Whelan*  
CITY ENGINEER

5/31/94  
DATE

DETAIL NO.  
P1343

**NOTES:**

1. REPLACEMENT PIPE MATERIAL SHALL BE IN KIND OR DUCTILE IRON.
2. WHERE POSSIBLE, ONE END OF THE REPLACEMENT PIPE SECTION SHALL CONNECT TO AN EXISTING BELL OR SPIGOT.
3. FLEXIBLE COUPLING SHALL BE THE CAST IRON TYPE AND SPECIFICALLY DESIGNED FOR USE ON THE PIPE SIZE AND MATERIAL(S) BEING CONNECTED. USE OF FULL CIRCLE REPAIR CLAMPS IS PROHIBITED.
4. THE NEW REPLACEMENT PIPE SECTION SHALL BE ADEQUATELY DRY BLOCKED PRIOR TO BACKFILLING.
5. BACKFILLING SHALL NOT BEGIN UNTIL LINE PRESSURE IS RESTORED AND CONNECTIONS INSPECTED FOR LEAKAGE BY WATER DEPARTMENT PERSONNEL.
6. DRY BLOCKS SHALL BE STANDARD SIZE SOLID MASONRY CONCRETE BLOCKS. (ASTM C-139)
7. REPLACEMENT PIPE SHALL BE CLEANED IN ACCORDANCE WITH SECTION 611.1.

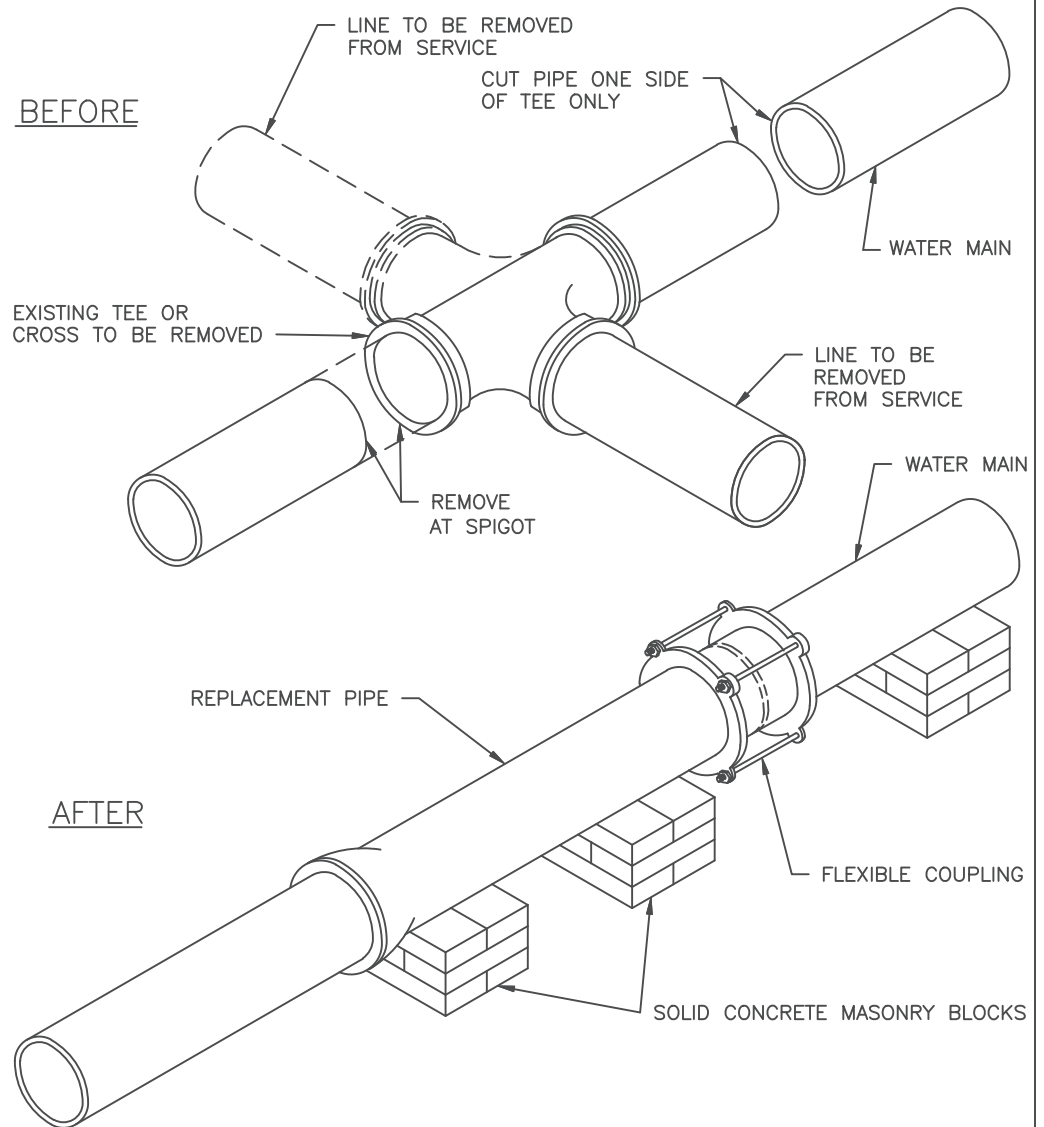

DETAIL NO.  
P1344



**City of Phoenix**  
**STANDARD DETAIL**

WATERLINE CUT OUT (TEES & CROSSES)  
FOR 12" DIA. MAIN AND SMALLER

APPROVED

*Kenny Whelan*  
CITY ENGINEER

7/9/92  
DATE

DETAIL NO.  
P1344



ASSEMBLY SIZE	APPROX. DIMENSION "A"
3"	14"
4"	16"-(22" OS&Y)
6"	20"-(30" OS&Y)
8"	25"-(40" OS&Y)
10"	29"-(48" OS&Y)
12"	32"-(56" OS&Y)

ASSEMBLY SIZE	APPROX DIM "B"
3"	10"
4"	11"
6"	12"
8"	22"
10"	23"
12"	24"

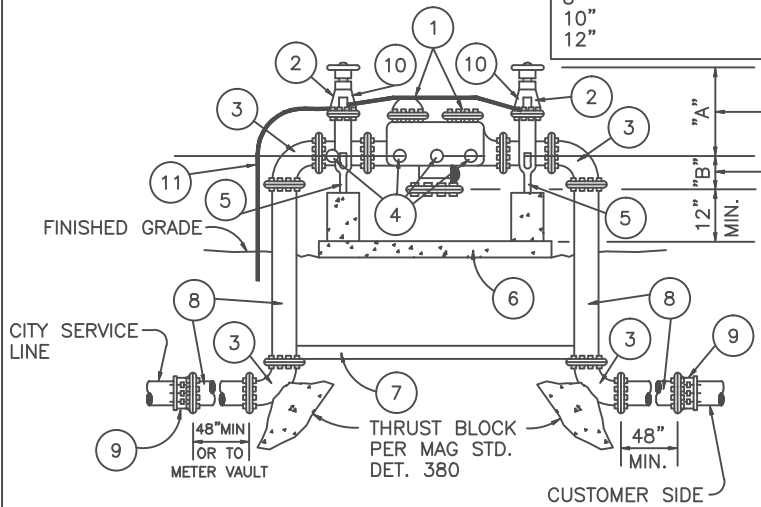

REDUCED PRESSURE PRINCIPLE DEVICE

GENERAL NOTES

- ASSEMBLY SHALL BE APPROVED BY U.S.C. FOUNDATION FOR CROSS CONNECTION AND HYDRAULIC RESEARCH.
- CONTACT CITY OF PHOENIX DEVELOPMENT SERVICES DEPARTMENT, CROSS-CONNECTION CONTROL FOR A LIST OF APPROVED BACKFLOW PREVENTION ASSEMBLIES.
- FOUR (4) TEST COCKS TO BE INSTALLED PER U.S.C.
- COPPER FITTINGS SHALL BE CONNECTED WITH LEAD-FREE SOLDER JOINTS.
- FINISHED GRADE BELOW BACKFLOW PREVENTER SHALL BE 95% COMPACTION.
- ASSEMBLY MAY BE PAINTED TO BLEND WITH LANDSCAPE SURFACE TREATMENT OR ON-SITE STRUCTURES.
- THE ASSEMBLY MAY ALSO BE SCREENED WITH SHRUBBERY OR BE ENCLOSED WITHIN A WALL TYPE STRUCTURE. ADEQUATE DRAINAGE FOR SURFACE WATER IS REQUIRED.
- ANY SCREENING/ENCLOSURE MUST PROVIDE A MINIMUM 18" ACCESS OPENING (UNSECURED GATES ARE ACCEPTABLE) AND SIDE WALLS OR SHRUBBERY MUST BE A MINIMUM OF 24" FROM THE OUTSIDE FACE OF ANY PORTION OF THE BACKFLOW PREVENTION DEVICE.
- ASSEMBLY MAY BE PROTECTED BY GUARD POSTS (MODIFY P-1359, HYDRANT GUARDS, PHOENIX SUPPLEMENT TO MAG).

LIST OF MATERIALS

- |   |  |
|---|--|
| <ul style="list-style-type: none"> <li>① APPROVED REDUCED PRESSURE PRINCIPLE BACKFLOW PREVENTION DEVICE.</li> <li>② GATE VALVE, RESILIENT SEATED (NON-RISING STEM)(O.S.&amp;Y. REQUIRED ON FIRELINES).</li> <li>③ 90° ELL (FLANGED D.I.P. 3" THROUGH 12").</li> <li>④ TEST COCK, RESILIENT SEATED (4 REQUIRED) FIT WITH BRASS PLUG.</li> <li>⑤ ADJUSTABLE PIPE SUPPORT PERMANENTLY ATTACHED TO BASE (4" AND LARGER ASSEMBLY ONLY).</li> <li>⑥ CONCRETE SUPPORT PAD 4" THICK BY 18" WIDE MINIMUM BENEATH 4" AND LARGER ASSEMBLIES. (CLASS "A" CONCRETE)</li> </ul> | <ul style="list-style-type: none"> <li>⑦ 3"x3"x1/4" STEEL ANGLE. BOLT TO FLANGE, EACH END WITH ONE BOLT. COAT WITH COAL TAR EPOXY (16 MILS) REQUIRED ON 4" AND LARGER ASSEMBLIES.</li> <li>⑧ PIPE SPOOL (FLANGED D.I.P. 3" THRU 12").</li> <li>⑨ FLANGED ADAPTER (WHEN REQUIRED).</li> <li>⑩ TAMPER SWITCH (ON FIRELINE ONLY, OPTIONAL).</li> <li>⑪ ELECTRICAL CONDUIT FOR TAMPER SWITCH.</li> </ul> |
|---|--|

DETAIL NO.  
P1351



**City of Phoenix**  
**STANDARD DETAIL**

REDUCED PRESSURE PRINCIPLE BACKFLOW PREVENTION  
ASSEMBLY INSTALLATION - 3" AND OVER

APPROVED

*Maria S. Demando*  
CITY ENGINEER

6/27/01  
DATE

DETAIL NO.  
P1351

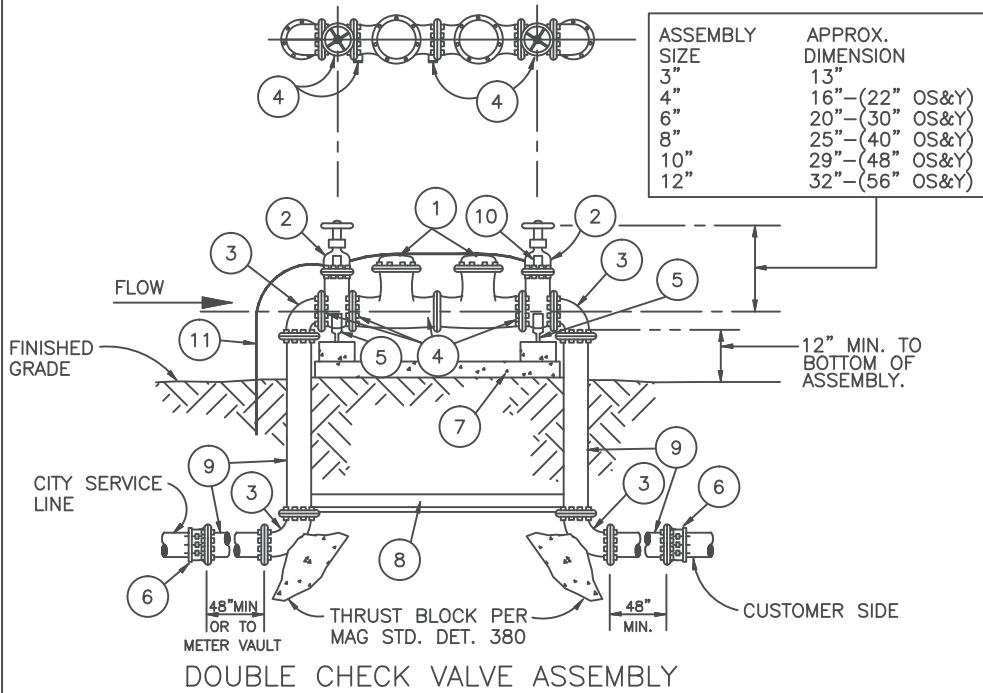

ASSEMBLY SIZE	APPROX. DIMENSION
3"	13"
4"	16"-(22" OS&Y)
6"	20"-(30" OS&Y)
8"	25"-(40" OS&Y)
10"	29"-(48" OS&Y)
12"	32"-(56" OS&Y)

GENERAL NOTES

1. ASSEMBLY SHALL BE APPROVED BY U.S.C. FOUNDATION FOR CROSS CONNECTION AND HYDRAULIC RESEARCH.
2. CONTACT CITY OF PHOENIX DEVELOPMENT SERVICES DEPARTMENT, CROSS-CONNECTION CONTROL FOR A LIST OF APPROVED BACKFLOW PREVENTION ASSEMBLIES.
3. FOUR (4) TEST COCKS TO BE INSTALLED PER U.S.C.
4. COPPER FITTINGS SHALL BE CONNECTED WITH LEAD-FREE SOLDER JOINTS.
5. FINISHED GRADE BELOW BACKFLOW PREVENTER SHALL BE 95% COMPACTION.
6. ASSEMBLY MAY BE PAINTED TO BLEND WITH LANDSCAPE SURFACE TREATMENT OR ON-SITE STRUCTURES.
7. THE ASSEMBLY MAY ALSO BE SCREENED WITH SHRUBBERY OR BE ENCLOSED WITHIN A WALL TYPE STRUCTURE. ADEQUATE DRAINAGE FOR SURFACE WATER IS REQUIRED.
8. ANY SCREENING/ENCLOSURE MUST PROVIDE A MINIMUM 18" ACCESS OPENING (UNSECURED GATES ARE ACCEPTABLE) AND SIDE WALLS OR SHRUBBERY MUST BE A MINIMUM OF 24" FROM THE OUTSIDE FACE OF ANY PORTION OF THE BACKFLOW PREVENTION DEVICE.
9. ASSEMBLY MAY BE PROTECTED BY GUARD POSTS (MODIFY P-1359, HYDRANT GUARDS, PHOENIX SUPPLEMENT TO MAG).

LIST OF MATERIALS

- |   |   |
|---|---|
| <ul style="list-style-type: none"> <li>① APPROVED DOUBLE CHECK VALVE ASSEMBLY.</li> <li>② GATE VALVE, RESILIENT SEATED (NON-RISING STEM)(O.S.&amp;Y. REQUIRED ON FIRELINE).</li> <li>③ 90° ELL (FLANGED D.I.P. 3" THROUGH 12").</li> <li>④ TEST COCK, RESILIENT SEATED (4 REQUIRED) FIT WITH BRASS PLUG.</li> <li>⑤ ADJUSTABLE PIPE SUPPORT PERMANENTLY ATTACHED TO BASE (4" AND LARGER ASSEMBLY ONLY).</li> <li>⑥ FLANGE ADAPTER (WHEN REQUIRED).</li> </ul> | <ul style="list-style-type: none"> <li>⑦ CONCRETE SUPPORT PAD 4" THICK BY 18" WIDE MINIMUM BENEATH 4" AND LARGER ASSEMBLIES. (CLASS "A" CONC).</li> <li>⑧ 3"x3"x1/4" STEEL ANGLE. BOLT TO FLANGE, EACH END WITH ONE BOLT. COAT WITH COAL TAR EPOXY (16 MILS) REQUIRED ON 4" AND LARGER ASSEMBLIES.</li> <li>⑨ PIPE SPOOL (FLANGED D.I.P. 3" THRU 12").</li> <li>⑩ TAMPER SWITCH (ON FIRELINE ONLY, OPTIONAL).</li> <li>⑪ ELECTRICAL CONDUIT FOR TAMPER SWITCH.</li> </ul> |
|---|---|

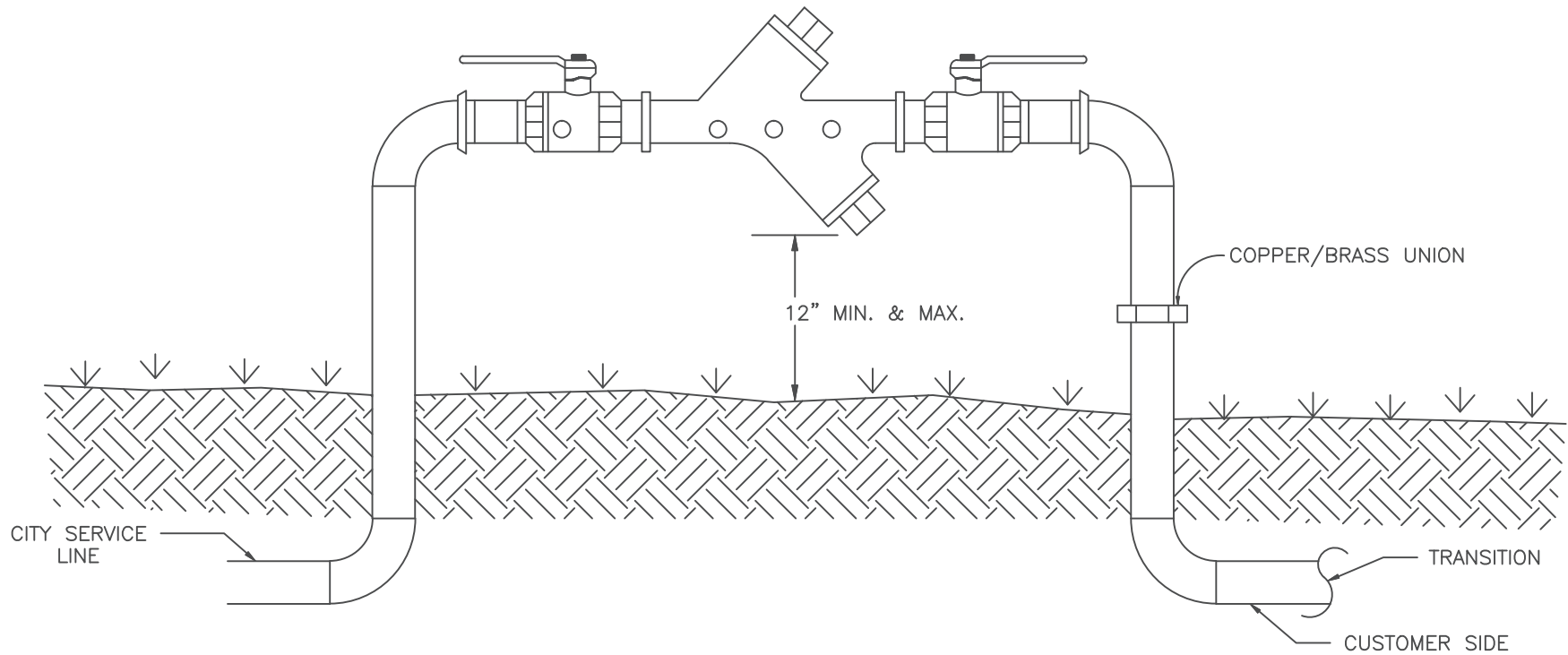

NOTES:

1. ALL PIPE/FITTINGS TO BE TYPE "K" COPPER.
2. CONTACT CITY OF PHOENIX DEVELOPMENT SERVICES DEPARTMENT, CROSS-CONNECTION CONTROL FOR A LIST OF APPROVED BACKFLOW PREVENTION ASSEMBLIES.
3. BACKFLOW PREVENTION ASSEMBLY MUST BE LEVEL AND INSTALLED A MINIMUM AND A MAXIMUM OF 12 INCHES FROM ASSEMBLY BODY TO FINAL GRADE.
4. TEST COCKS, (4) SHALL BE FITTED WITH BRASS PLUGS INSTALLED WITH TEFLON TAPE.
5. SHUTOFF VALVES TO BE RESILIENT BALL TYPE WITH REMOVABLE HANDLES.
6. COMPRESSION TYPE FITTINGS ARE NOT ALLOWED.
7. INSTALL THE BACKFLOW PREVENTION ASSEMBLY IMMEDIATELY DOWNSTREAM OF THE CITY WATER METER.
8. A COPPER/BRASS UNION MUST BE INSTALLED IN THE MIDDLE OF THE DOWNSTREAM RISER.
9. ASSEMBLY SHALL BE APPROVED BY U.S.C. FOUNDATION FOR CROSS-CONNECTION CONTROL AND HYDRAULIC RESEARCH.
10. COPPER FITTINGS SHALL BE CONNECTED WITH LEAD-FREE SOLDER JOINTS.
11. TRANSITION FROM "K" COPPER TO OTHER APPROVED PIPING MATERIALS SHALL BE IN THE HORIZONTAL PIPING A MINIMUM OF 12" BELOW GRADE.

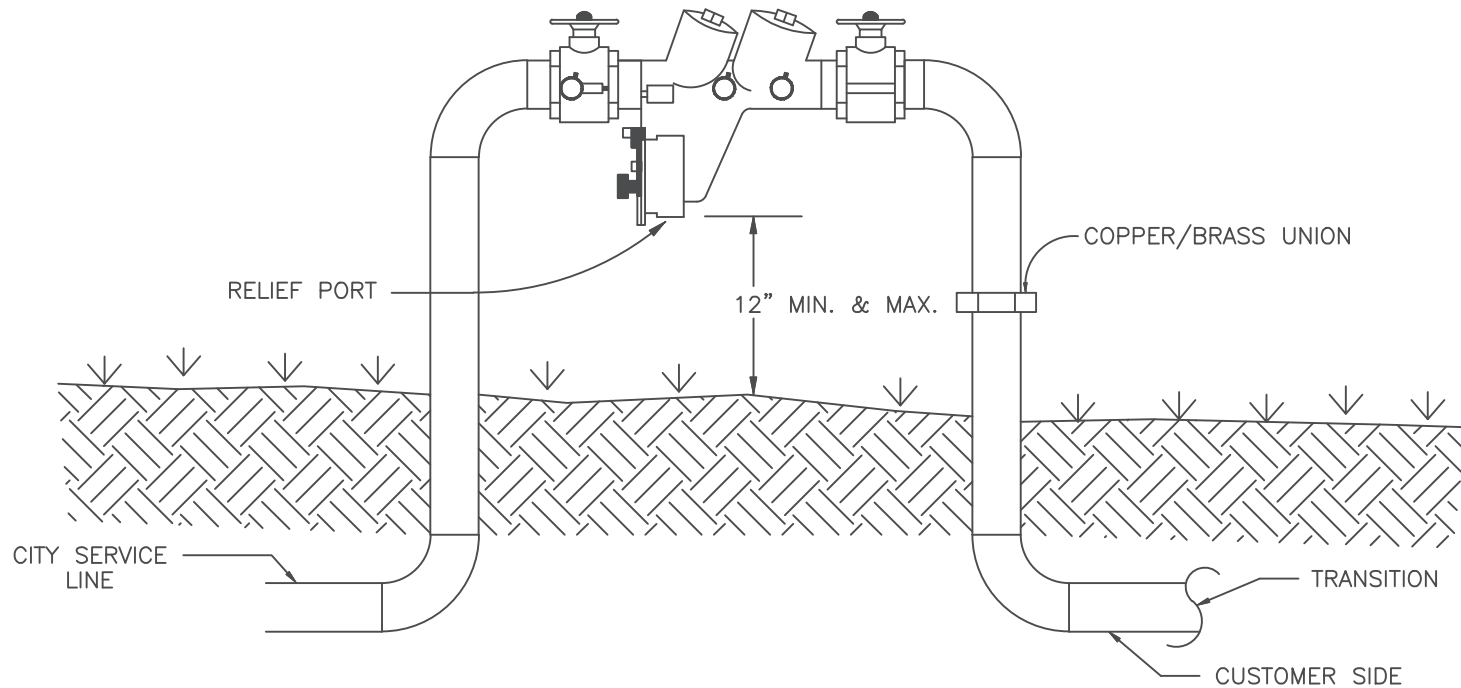

NOTES:

1. ALL PIPE/FITTINGS TO BE TYPE "K" COPPER.
2. ASSEMBLY SHALL BE APPROVED BY U.S.C. FOUNDATION FOR CROSS-CONNECTION CONTROL AND HYDRAULIC RESEARCH.
3. INSTALL BACKFLOW PREVENTION ASSEMBLY WITH RELIEF PORT FACING TOWARD THE GROUND.
4. BACKFLOW PREVENTION ASSEMBLY MUST BE LEVEL AND INSTALLED A MINIMUM AND A MAXIMUM OF 12 INCHES FROM RELIEF PORT TO FINAL GRADE.
5. PAVER CONCRETE BLOCK UNDER RELIEF PORT, SET AT FINAL GRADE.
6. TEST COCKS, (4) SHALL BE FITTED WITH BRASS PLUGS AND INSTALLED WITH TEFLON TAPE.
7. SHUTOFF VALVES TO BE RESILIENT BALL TYPE WITH REMOVABLE HANDLES.
8. COMPRESSION TYPE FITTINGS ARE NOT ALLOWED.
9. INSTALL THE BACKFLOW PREVENTION ASSEMBLY IMMEDIATELY DOWNSTREAM OF THE CITY WATER METER.
10. A COPPER/BRASS UNION MUST BE INSTALLED IN THE MIDDLE OF THE DOWNSTREAM RISER.
11. CONTACT CITY OF PHOENIX DEVELOPMENT SERVICES DEPARTMENT, CROSS-CONNECTION CONTROL FOR A LIST OF APPROVED BACKFLOW PREVENTION ASSEMBLIES.
12. COPPER FITTINGS SHALL BE CONNECTED WITH LEAD-FREE SOLDER JOINT.
13. TRANSITION FROM "K" COPPER TO OTHER APPROVED PIPING MATERIAL SHALL BE IN THE HORIZONTAL PIPING A MINIMUM OF 12" BELOW GRADE.

DETAIL NO.  
P1354



**City of Phoenix**  
**STANDARD DETAIL**

REDUCED PRESSURE PRINCIPLE BACKFLOW PREVENTION  
ASSEMBLY INSTALLATION - 2 1/2" AND UNDER

APPROVED

*Maria S. Demando*  
CITY ENGINEER

6/27/01  
DATE

DETAIL NO.  
P1354

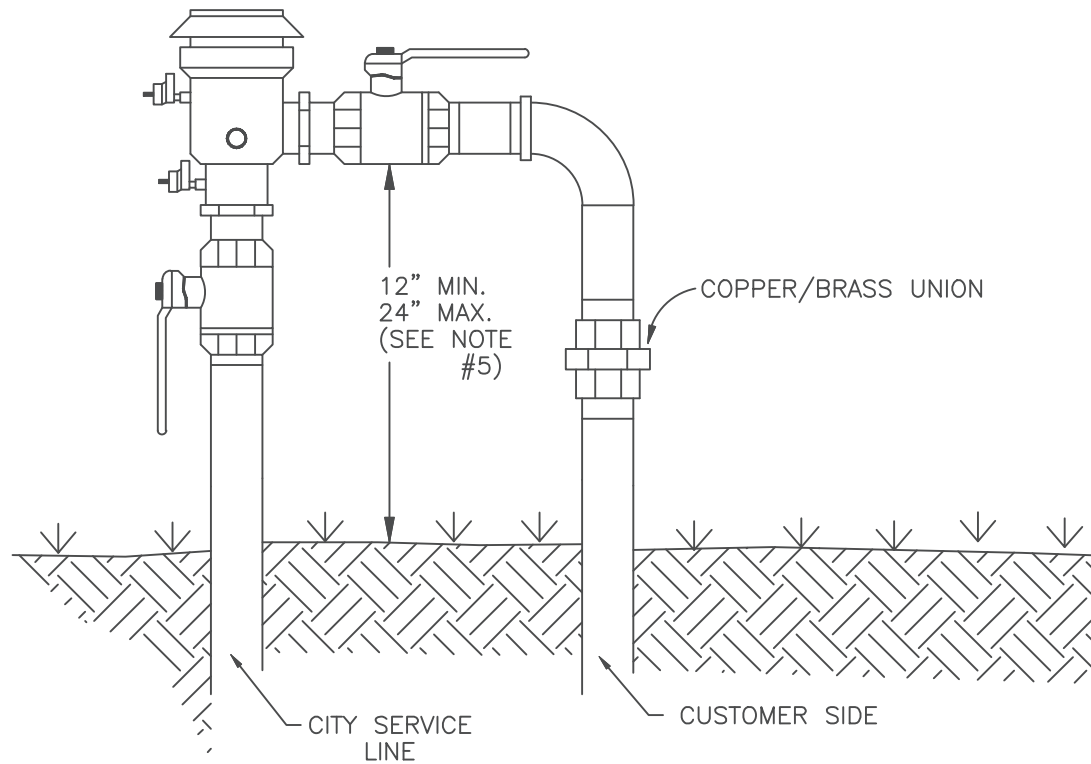

NOTES:

1. CONTACT CITY OF PHOENIX DEVELOPMENT SERVICES DEPARTMENT, CROSS-CONNECTION CONTROL FOR A LIST OF APPROVED PRESSURE VACUUM BREAKER ASSEMBLIES.
2. ASSEMBLY SHALL BE APPROVED BY U.S.C. FOUNDATION FOR CROSS-CONNECTION CONTROL AND HYDRAULIC RESEARCH.
3. TWO (2) TEST COCKS SHALL BE FITTED WITH BRASS PLUGS INSTALLED WITH TEFLON TAPE.
4. SHUTOFF BALL VALVES MUST BE RESILIENT SEATED VALVES AS PER U.S.C..
5. ASSEMBLY MUST BE INSTALLED 12 INCHES ABOVE THE HIGHEST OUTLET ON THE SYSTEM. IF THE DISTANCE EXCEEDS 24 INCHES A REDUCED PRESSURE BACKFLOW PREVENTION ASSEMBLY MUST BE USED.
6. ALL PIPE/FITTINGS TO BE TYPE "K" COPPER.
7. A COPPER/BRASS UNION MUST BE INSTALLED IN THE MIDDLE OF THE DOWNSTREAM RISER.
8. INSTALL THE BACKFLOW PREVENTION ASSEMBLY IMMEDIATELY DOWNSTREAM OF THE CITY WATER METER.
9. COPPER FITTINGS TO BE CONNECTED WITH LEAD-FREE SOLDER JOINTS.
10. TRANSITION FROM "K" COPPER TO OTHER APPROVED PIPING MATERIALS SHALL BE IN THE HORIZONTAL PIPING A MINIMUM OF 12" BELOW GRADE.

DETAIL NO.  
P1355



**City of Phoenix**  
**STANDARD DETAIL**

PRESSURE VACUUM BREAKER ASSEMBLY  
INSTALLATION - 2" AND UNDER

APPROVED

*Maria S. Demando*  
CITY ENGINEER

6/27/01  
DATE

DETAIL NO.  
P1355

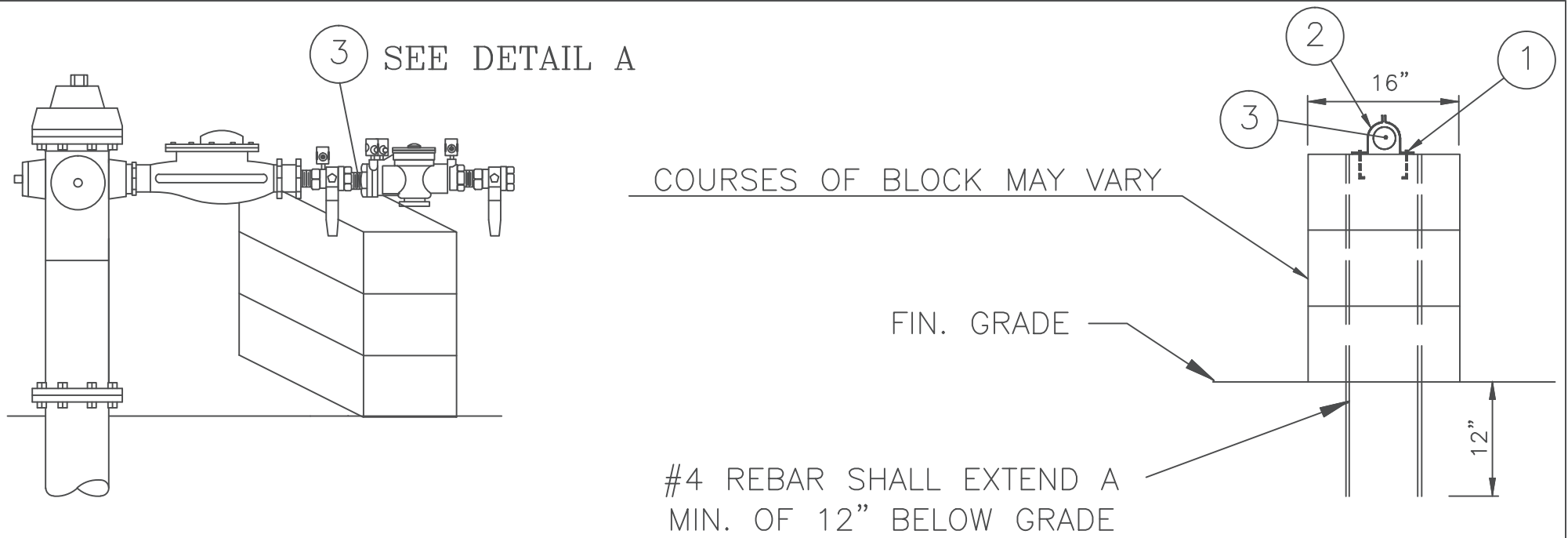

# Detail A

## NOTES:

1. SECURE BACKFLOW ASSEMBLY WITH APPROVED ANCHORS TO 8"X8"X16" TYPE "B" CONCRETE FILLED BLOCK WITH 2 #4 REBARS. ASSEMBLY SHALL BE TESTED BY CERTIFIED BACKFLOW TESTER.
2. 2-PIECE CLAMP WITH APPROVED ANCHORS.
3. BACKFLOW ASSEMBLY FOR USE WITH DETAIL P1354.
4. CONTACT CITY OF PHOENIX DEVELOPMENT SERVICES DEPARTMENT, CROSS-CONNECTION CONTROL FOR A LIST OF APPROVED BACKFLOW PREVENTION ASSEMBLIES.

DETAIL NO. P1356	 <b>City of Phoenix</b> STANDARD DETAIL	TEMPORARY SUPPORT FOR FIRE HYDRANT BACKFLOW ASSEMBLY	APPROVED  CITY ENGINEER	DETAIL NO. P1356 6/27/01 DATE
---------------------	---	---	--	--

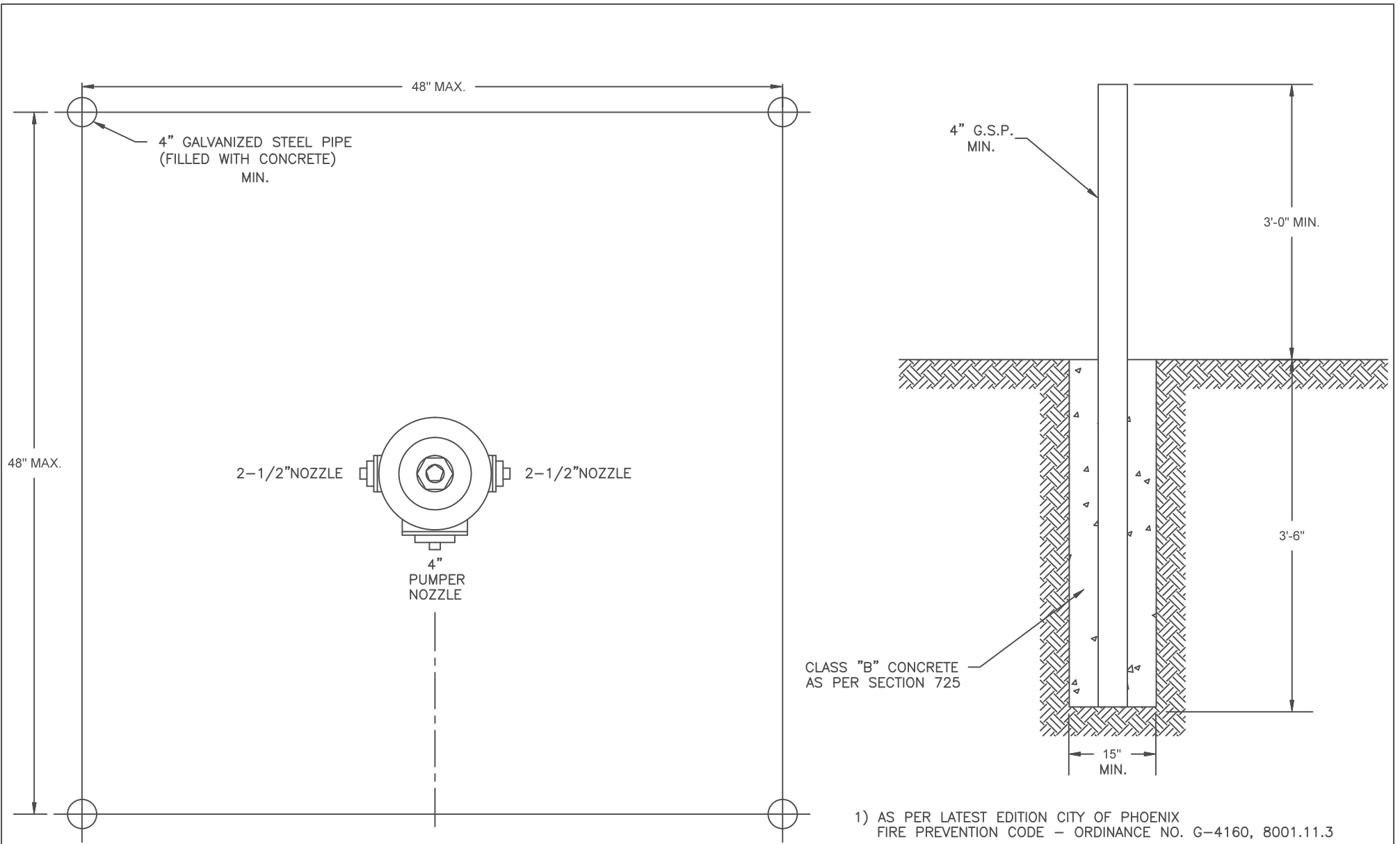

DETAIL NO.  
P1359



**City of Phoenix**  
STANDARD DETAIL

HYDRANT GUARDS

APPROVED

*Maria S. Demando*  
CITY ENGINEER

6/27/01  
DATE

DETAIL NO.  
P1359

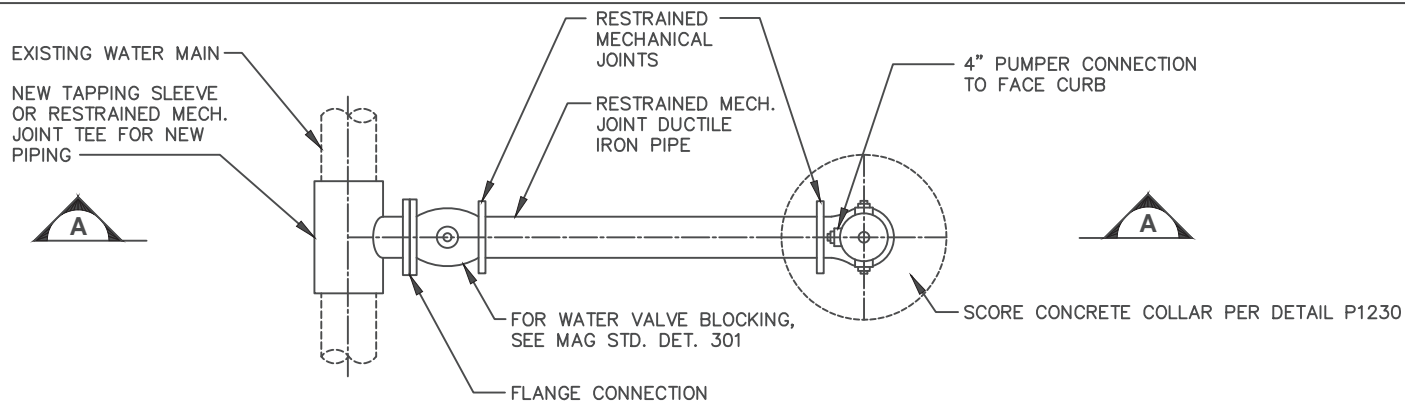

PLAN VIEW

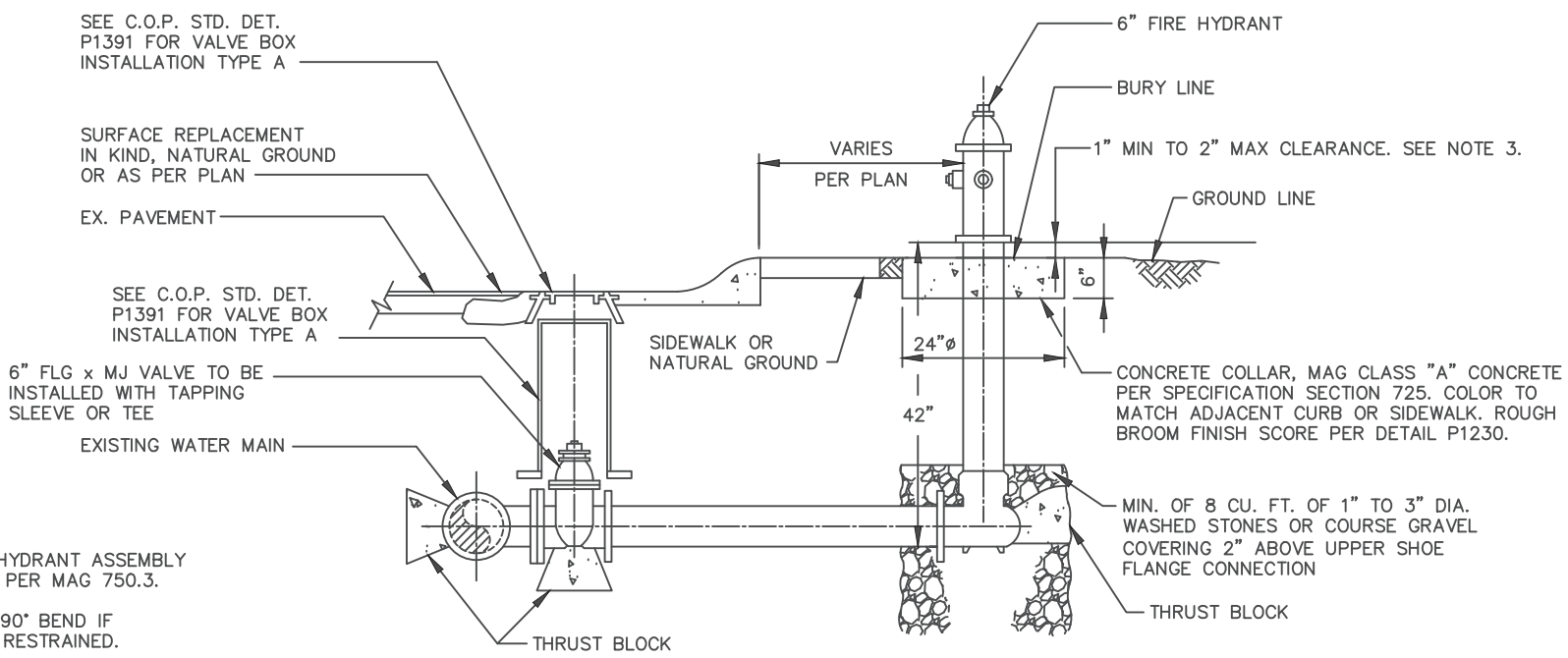

SECTION 'A-A'

NOTES:

1. ALL JOINTS IN FIRE HYDRANT ASSEMBLY TO BE RESTRAINED JOINT PER MAG 750.3.
2. REVERSE TAPS AND 90° BEND IF NEEDED SHALL BE FULLY RESTRAINED.
3. FINISHED GRADE IS DEFINED BY ADJACENT NATURAL GROUND, SIDEWALK, PAVEMENT OR CURB. FINISHED GRADE OR NEARBY OBSTRUCTIONS SHALL NOT DENY WRENCH ACCESS TO THE BOTTOM FLANGE BOLTS.
4. THRUST BLOCKS ARE REQUIRED IN ADDITION TO RESTRAINED JOINTS AS SHOWN.



2-1/2" HYDRANT NOZZLE

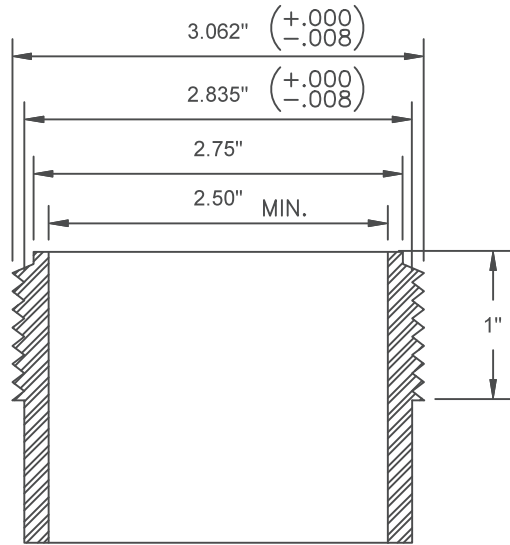

4" HYDRANT NOZZLE

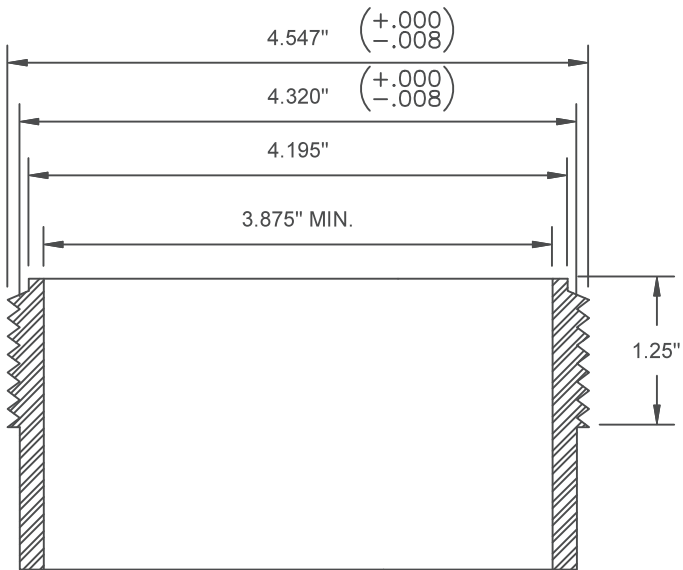

2-1/2" CAP

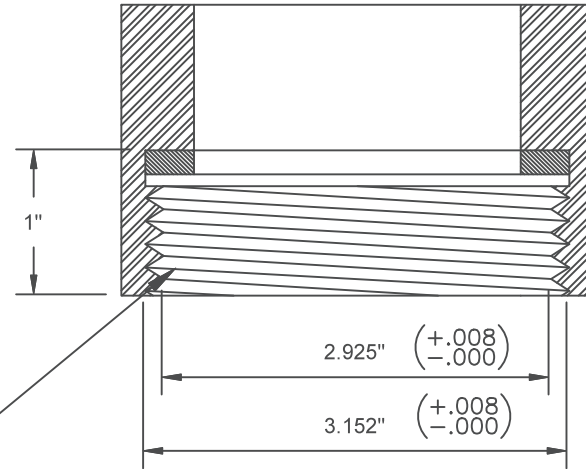

4" CAP

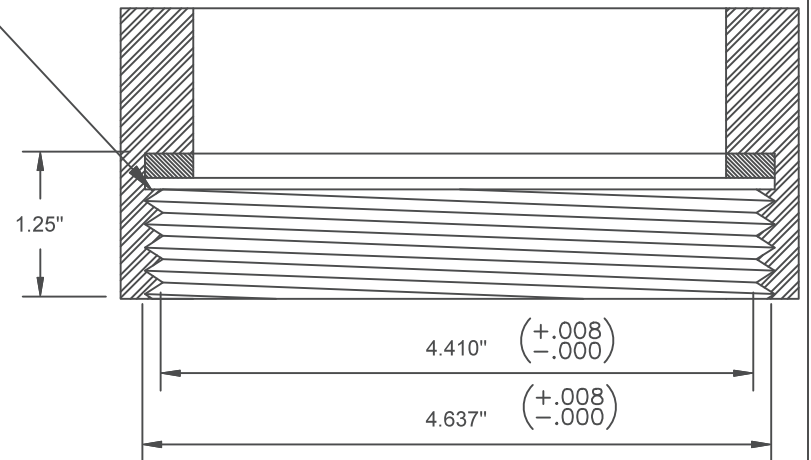

6 THREADS PER INCH

DETAIL NO.  
P1361



**City of Phoenix**  
**STANDARD DETAIL**

FIRE HYDRANT THREADS  
2 1/2" & 4"

APPROVED

*Kenny Whelan*  
CITY ENGINEER

7/9/92  
DATE

DETAIL NO.  
P1361

**NOTES:**

1. OBSTRUCTIONS SUCH AS UTILITY POLES, STREET SIGNS, IRRIGATION BOXES, FENCES, ETC., MUST NOT BE PLACED BETWEEN CURB AND HYDRANT.
2. DIMENSIONS SHOWN ON CONSTRUCTION DRAWINGS SUPERSEDE LOCATIONS SHOWN HERE.
3. ON LOCATIONS IN MIDBLOCK, THE FIRE HYDRANT WILL BE ALIGNED WITH A PROPERTY LINE.

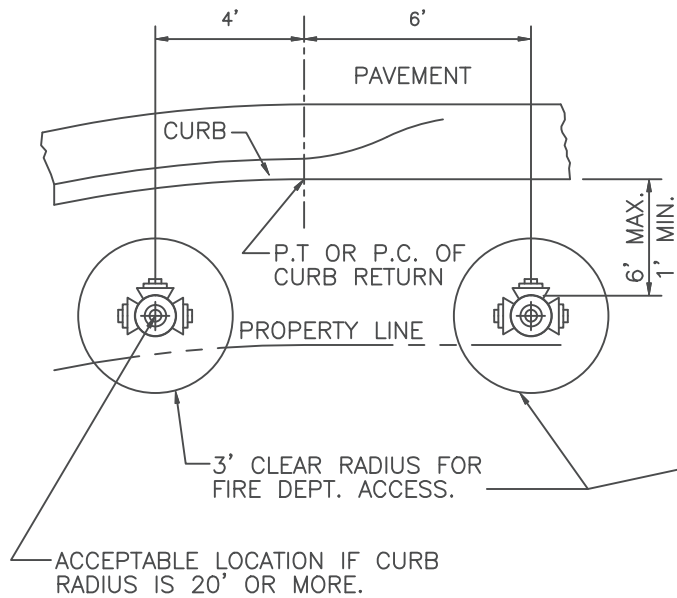

LANDSCAPE AREA WITH PARKWAY  
OR NO SIDEWALK ADJACENT TO CURB

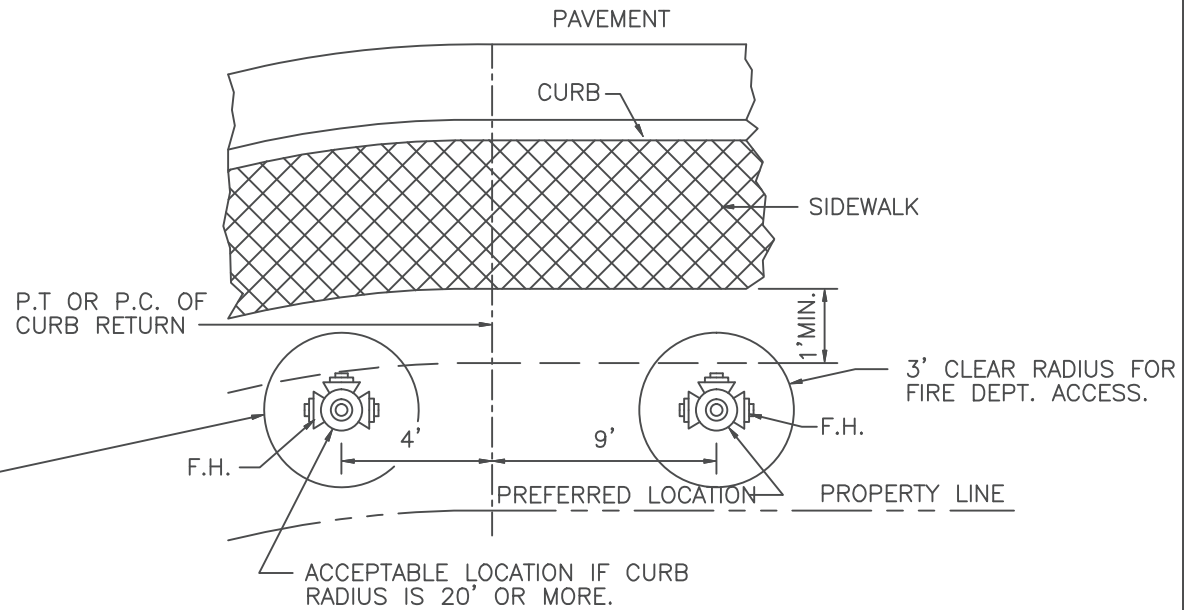

AREA WITH SIDEWALK ADJACENT TO CURB

DETAIL NO.  
P1362



FIRE HYDRANT LOCATION

APPROVED

*Maria S. Demando*  
CITY ENGINEER

7/19/04  
DATE

DETAIL NO.  
P1362

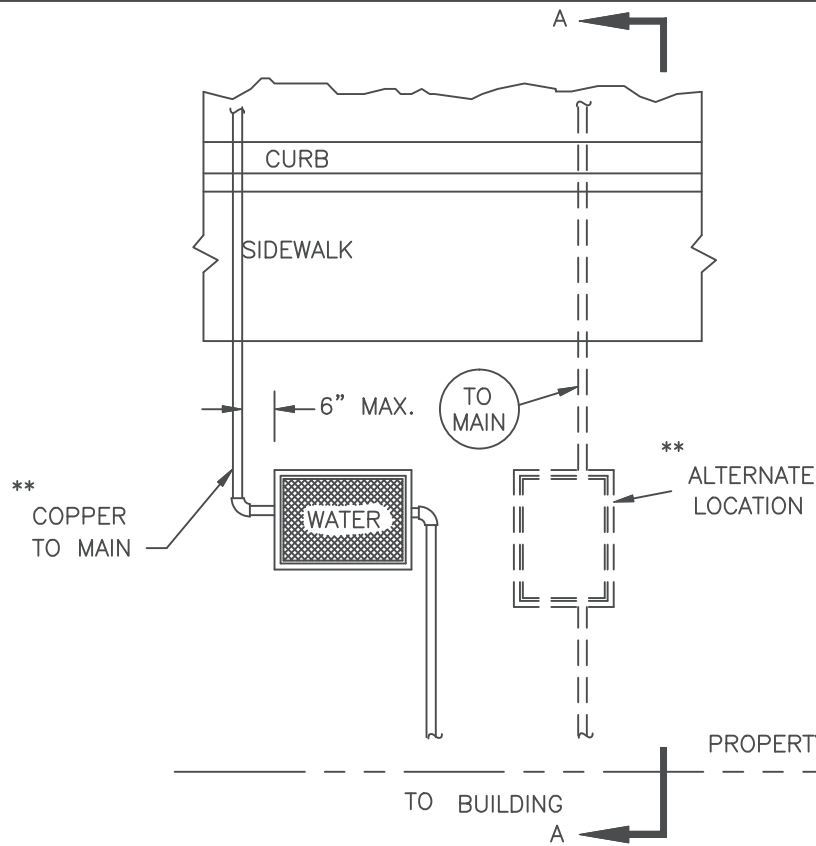

PLAN VIEW WITH SIDEWALK  
ADJACENT TO CURB

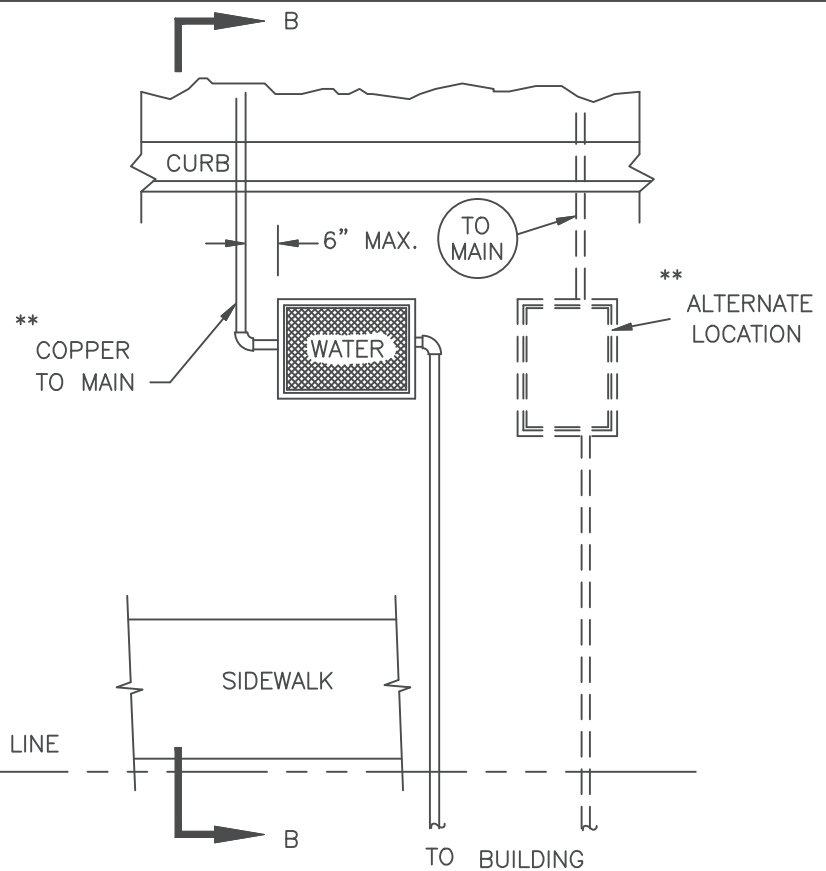

PLAN VIEW WITH PARKWAY  
OR NO SIDEWALK

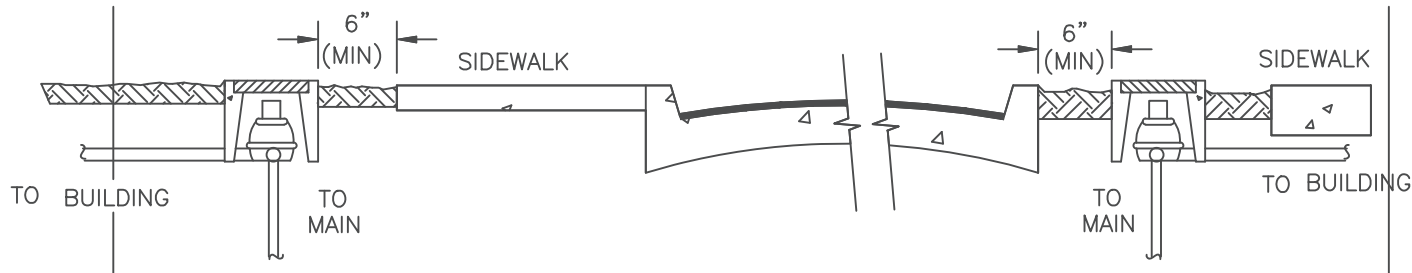

SECTION A-A

SECTION B-B

DETAIL NO.  
P1363



**City of Phoenix**  
**STANDARD DETAIL**

WATER METER LOCATION

APPROVED

*Maria Saldamando*  
CITY ENGINEER

7/3/00  
DATE

DETAIL NO.  
P1363

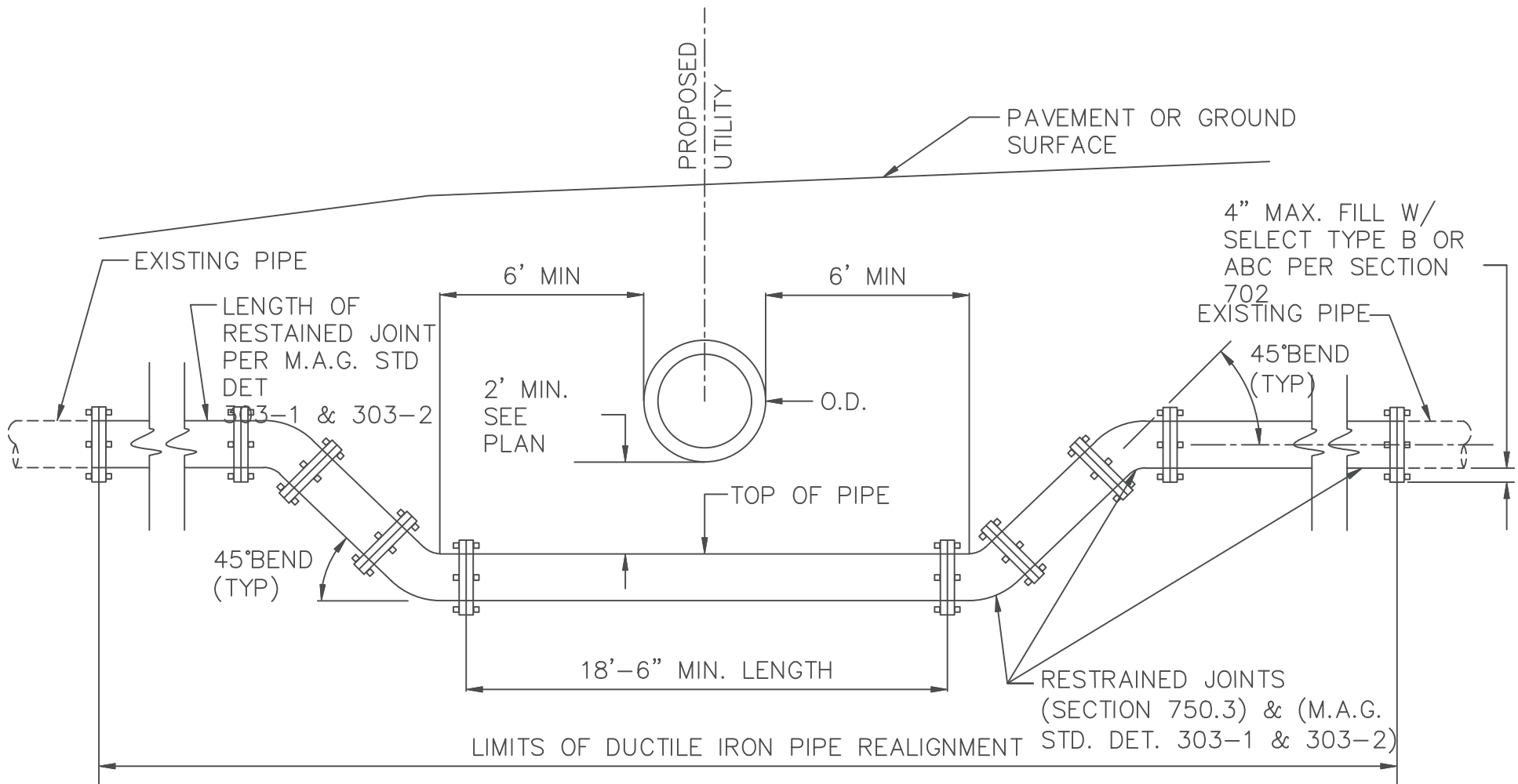

DETAIL NO.  
P1370



**City of Phoenix**  
**STANDARD DETAIL**

VERTICAL REALIGNMENT  
OF WATERLINE

APPROVED

*[Signature]*  
CITY ENGINEER

12/10/2012  
DATE

DETAIL NO.  
P1370

**NOTES:**

1. VALVE OPERATION NUT EXTENSION: SEE DETAIL P1391-1  
EXTENSION TO VALVE STEMS REQUIRED ON ALL VALVES WHERE OPERATING  
NUT IS OVER 5' BELOW SURFACE. LENGTH TO FIT EACH INSTALLATION.
2. IF TWO OR MORE JOINTS OF C900 PVC "WATER" PIPE RISER ARE NEEDED, THEY SHALL BE  
COUPLED AND GLUED WITH APPROPRIATE PVC GLUE TO FORM A DEBRIS-TIGHT JOINT.
3. VALVE BOX SHALL BE ADJUSTED TO THE FINISH GRADE AFTER PLACING  
THE ASPHALTIC CONCRETE SURFACE.
4. USE PARKSON TYLER, APCO, OR EQUAL DEEP SKIRTED COVER LID (4" DEEP OR MORE)  
C.I. MIN. T.S. 30,000 P.S.I. USE SECURE POLYMER VALVE BOX LID WITH LID-RETENTION  
ELASTOMERIC SEAL PER DETAIL P1270-1 WHERE "SECURE" LIDS ARE SPECIFIED.
5. GROUND BELOW CONCRETE PAD TO BE COMPACTED TO MIN. 95% OF MAX DENSITY.
6. INSTALL DEBRIS CAP PER DETAIL P1165.

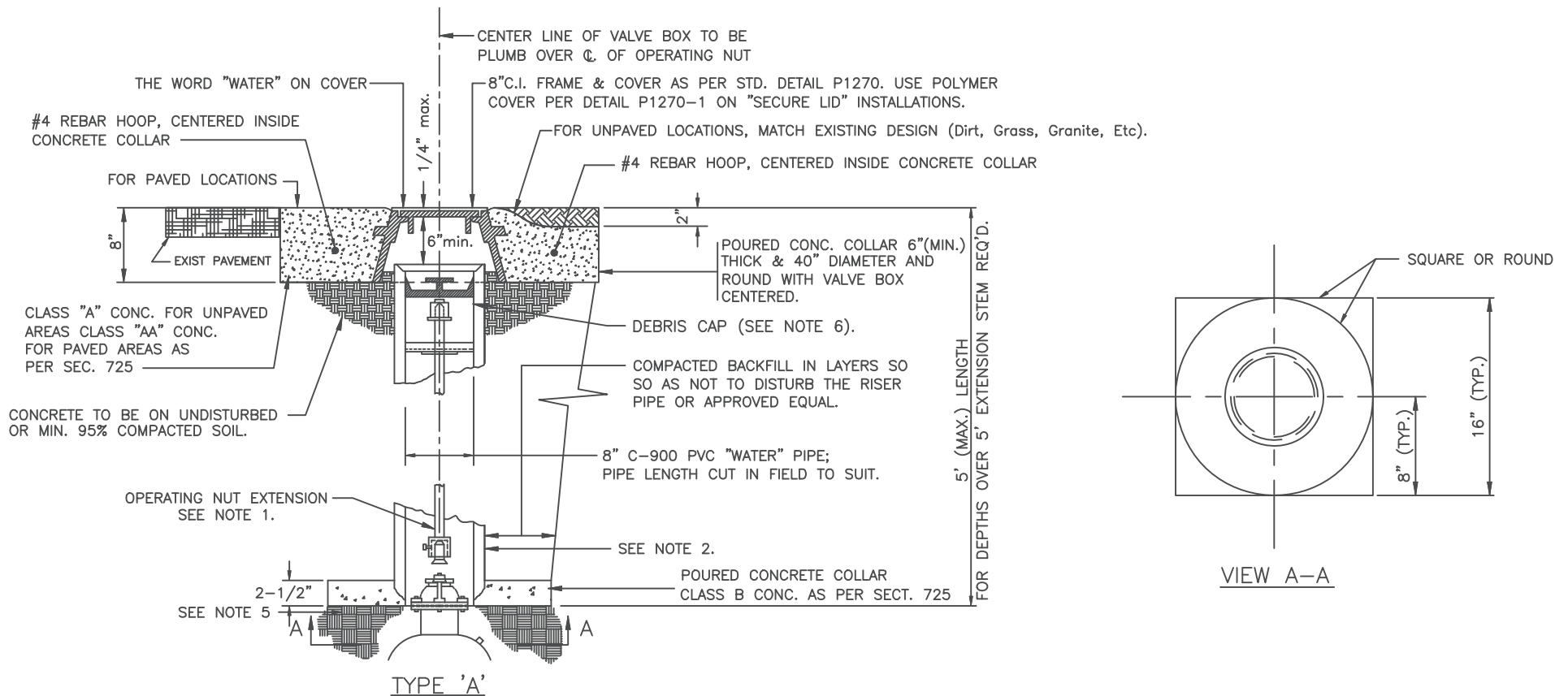

DETAIL NO.  
P1391



**City of Phoenix**  
**STANDARD DETAIL**

VALVE BOX INSTALLATION

APPROVED

*[Signature]*  
ACTING CITY ENGINEER

7/31/08  
DATE

DETAIL NO.  
P1391

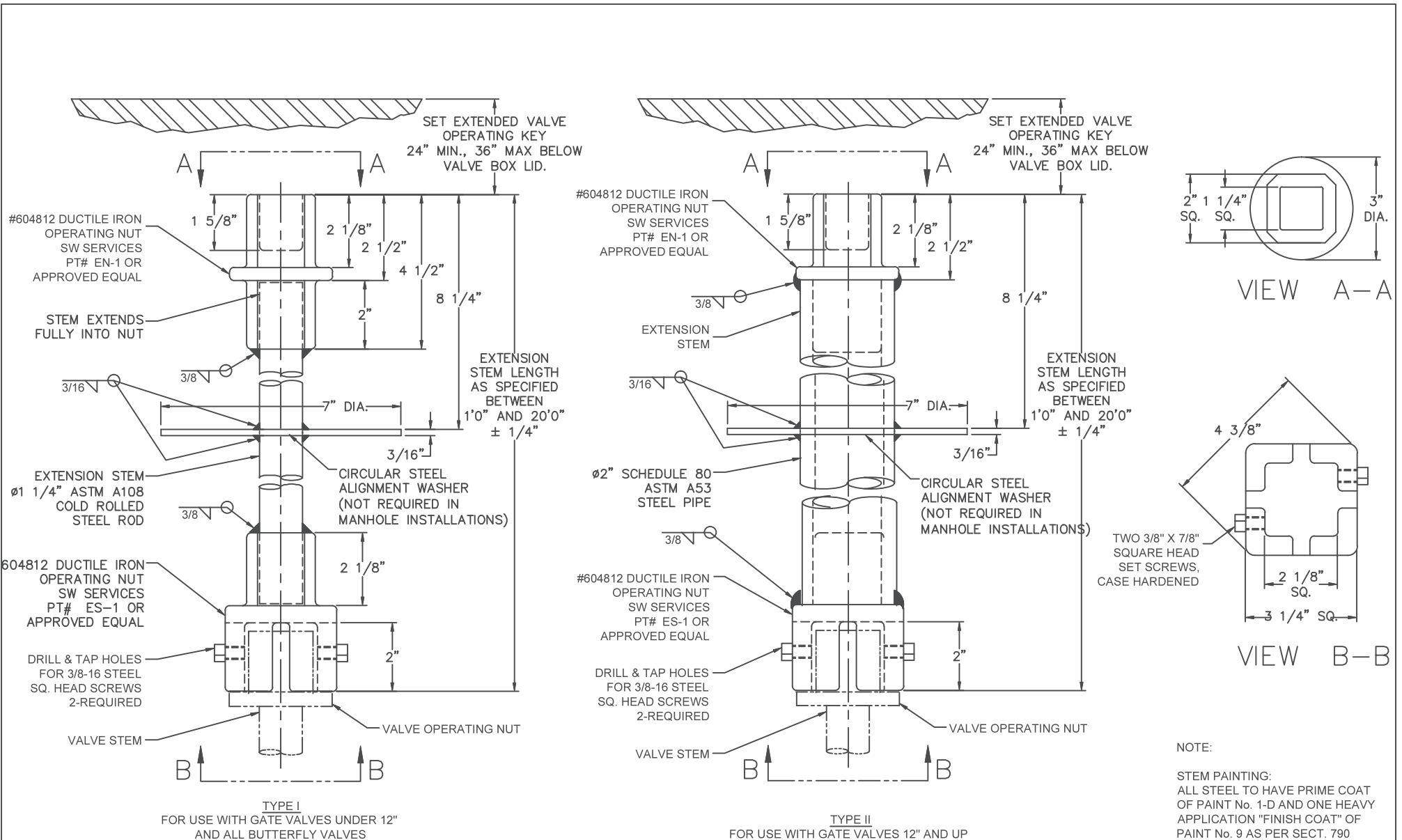

6/27/01  
DATE

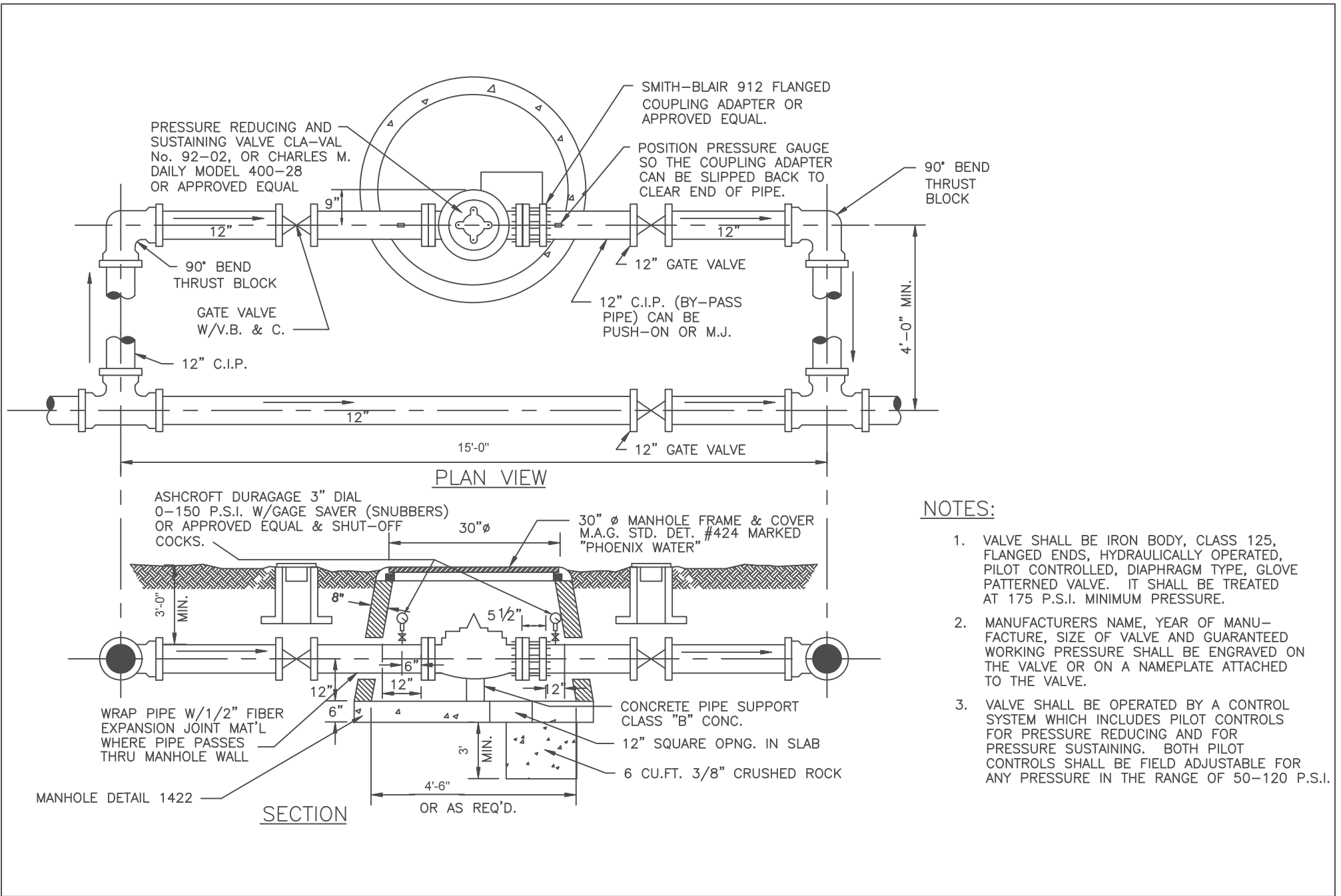

**NOTES:**

1. VALVE SHALL BE IRON BODY, CLASS 125, FLANGED ENDS, HYDRAULICALLY OPERATED, PILOT CONTROLLED, DIAPHRAGM TYPE, GLOVE PATTERNED VALVE. IT SHALL BE TREATED AT 175 P.S.I. MINIMUM PRESSURE.
2. MANUFACTURERS NAME, YEAR OF MANUFACTURE, SIZE OF VALVE AND GUARANTEED WORKING PRESSURE SHALL BE ENGRAVED ON THE VALVE OR ON A NAMEPLATE ATTACHED TO THE VALVE.
3. VALVE SHALL BE OPERATED BY A CONTROL SYSTEM WHICH INCLUDES PILOT CONTROLS FOR PRESSURE REDUCING AND FOR PRESSURE SUSTAINING. BOTH PILOT CONTROLS SHALL BE FIELD ADJUSTABLE FOR ANY PRESSURE IN THE RANGE OF 50-120 P.S.I.

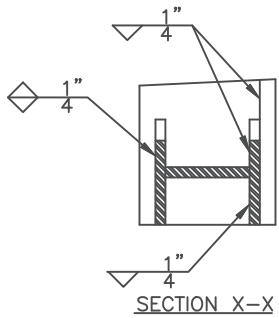

PIPE SIZE	A	B
8"	8"	15"
10"	9"	17"
12"	10"	19"

**NOTES:**

1. MINIMUM 2 SUPPORTS PER JOINT OF PIPE.
2. ALL NUTS SHALL BE STAINLESS STEEL SERIES 8-18.
3. ALL BOLTS SHALL HAVE A LOCK WASHER UNDER THE NUT.

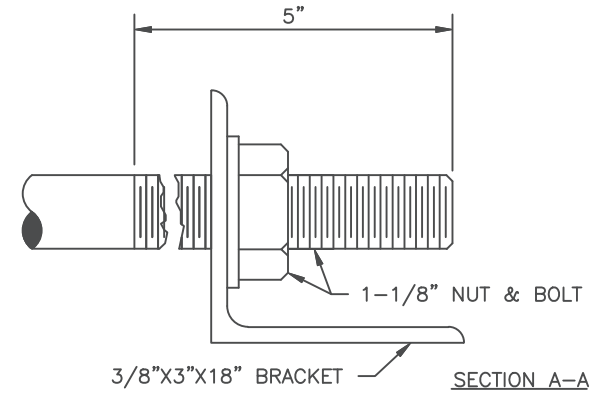
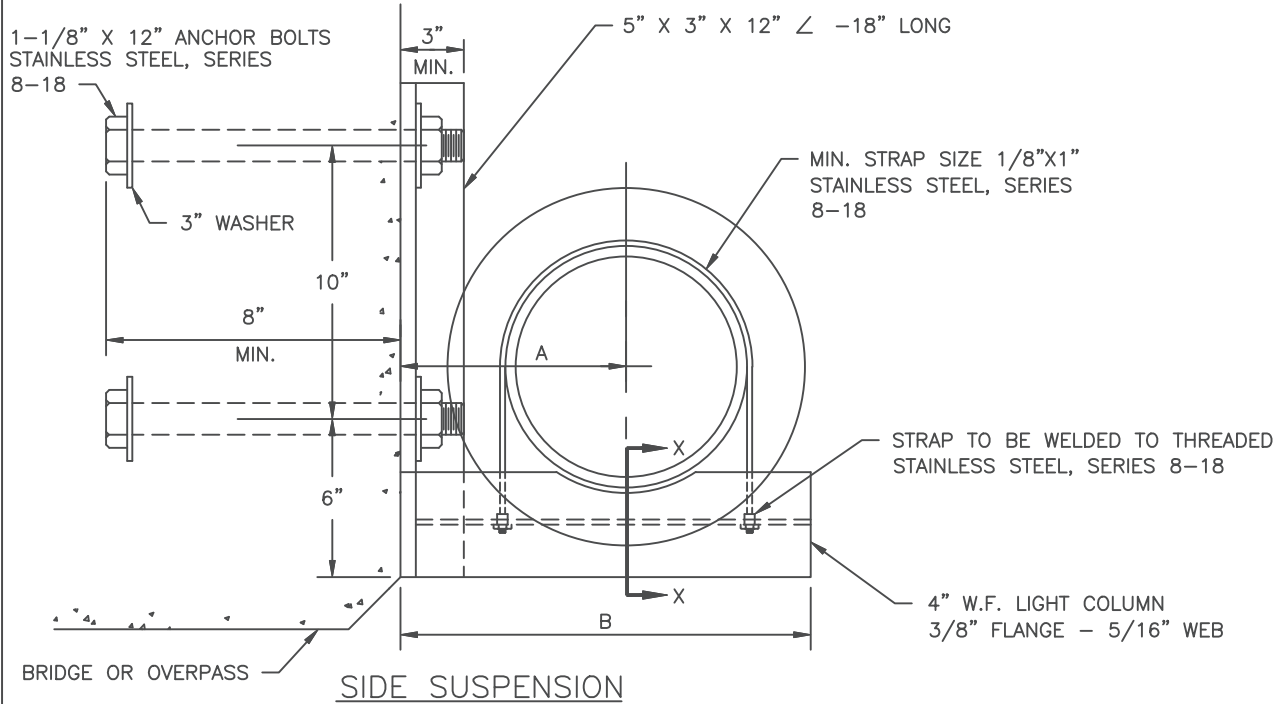
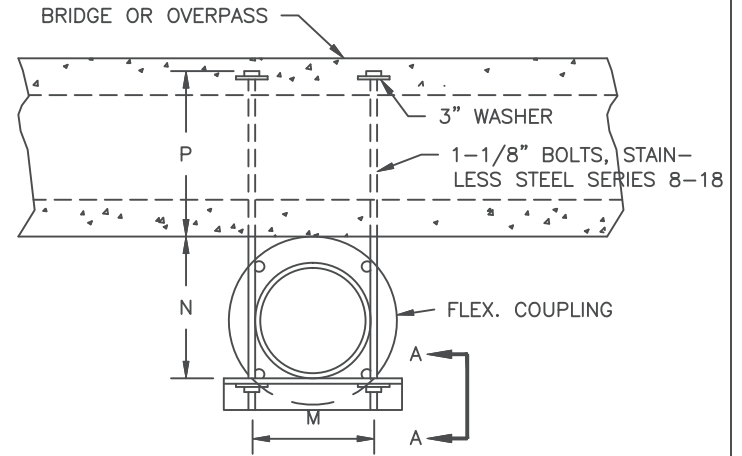

PIPE SIZE	M	N	P
8"	10.25"	12"	8"
10"	12.5"	14"	8"
12"	15"	16"	8"

**BOTTOM SUSPENSION**



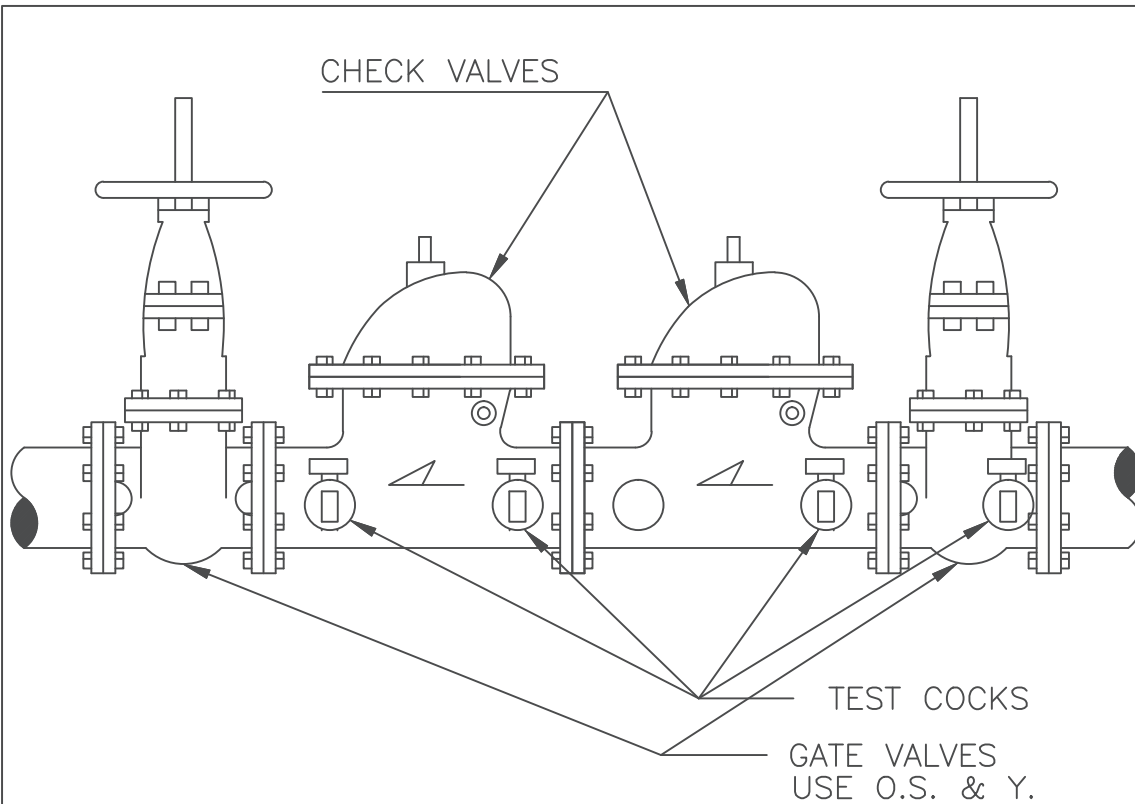

NOTES:

1. THE CHECK VALVE SHALL BE LOADED INTERNALLY SO THAT WHEN THE SUPPLY PRESSURE IS 1 P.S.I., AND THE OUTLET PRESSURE IS ATMOSPHERIC, EACH CHECK VALVE WILL BE DRIP-TIGHT IN THE NORMAL DIRECTION OF FLOW.
2. CLAPPER FACING RINGS SHALL BE MOLDED SYNTHETIC RUBBER (SHORE DUROMETER HARDNESS 35-45).
3. ASSEMBLY IS TO MEET A.W.W.A. STANDARD C 506, BACK FLOW PREVENTION DEVICES.
4. PLACEMENT & LOCATION OF DOUBLE CHECK VALVE ASSEMBLY SHALL BE APPROVED BY WATER & WASTEWATER DEPARTMENT.
5. TEST COCKS SHALL HAVE FEMALE ENDS (I.P. THREADS) ON DISCHARGE SIDE.

NOMINAL SIZE OF ASSEMBLY	MINIMUM SIZE TEST COCK
LESS THAN OR EQUAL TO 2"	1/4"
2 1/2" - 4"	1/2"
6" & OVER	3/4"

DETAIL NO.  
P1396



**City of Phoenix**  
**STANDARD DETAIL**

DOUBLE CHECK VALVE ASSEMBLY

APPROVED

*Kenny Whelan*  
CITY ENGINEER

7/9/92  
DATE

DETAIL NO.  
P1396



7/8" DIA. VENT HOLE  
1 OPEN PICKSLOT

OPEN PICKSLOT



7/8" DIA. VENT HOLE  
(2) CONCEALED PICKSLOTS

CONCEALED PICKSLOT

NOTES:

1. ALL LIDS AND FRAMES TO BE FURNISHED WITH MACHINED HORIZONTAL BEARING SURFACES.
2. MEET H-20 LOAD RATING REQUIREMENTS.
3. WATERTIGHT COVERS SHALL BE FURNISHED WITH T-GASKET IN FRAME OR COVER.
4. ADJUST WORDING TO "PHOENIX WATER," AS NECESSARY.



NO VENT HOLE  
(2) CONCEALED PICKSLOTS

WATERTIGHT



(4) 1/2" X 2" HEX-HEAD S.S. BOLTS & WASHERS  
NO VENT HOLE  
(2) CONCEALED PICKSLOTS

BOLTDOWN WATERTIGHT

5. SEE MAG DETAIL NUMBERS: 423 & 424 FOR ADDITIONAL REQUIREMENT.



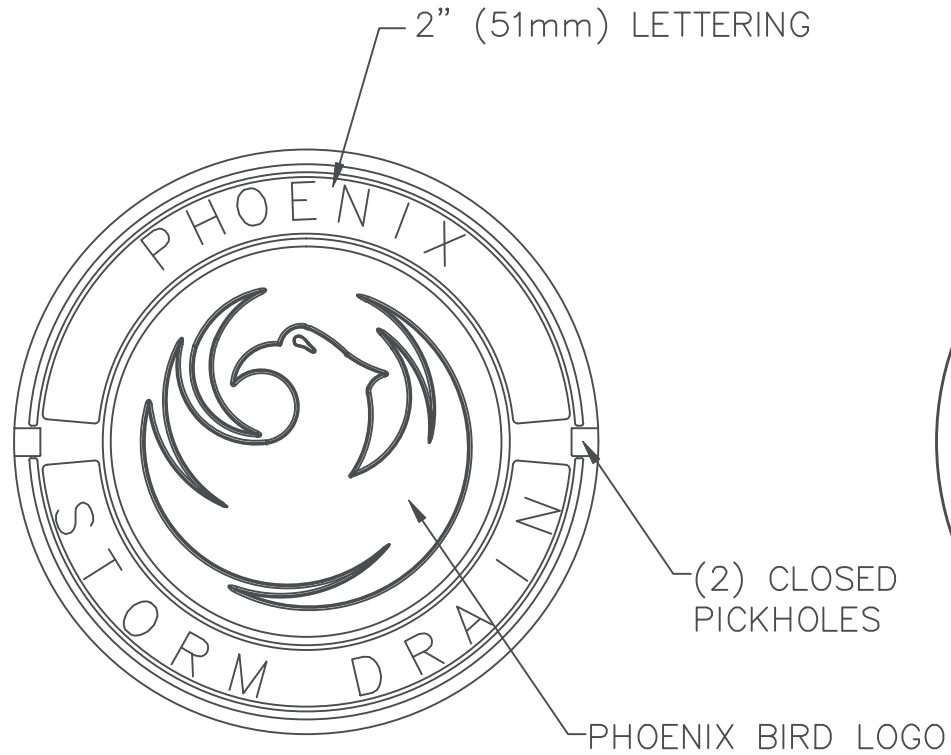

PLAN VIEW

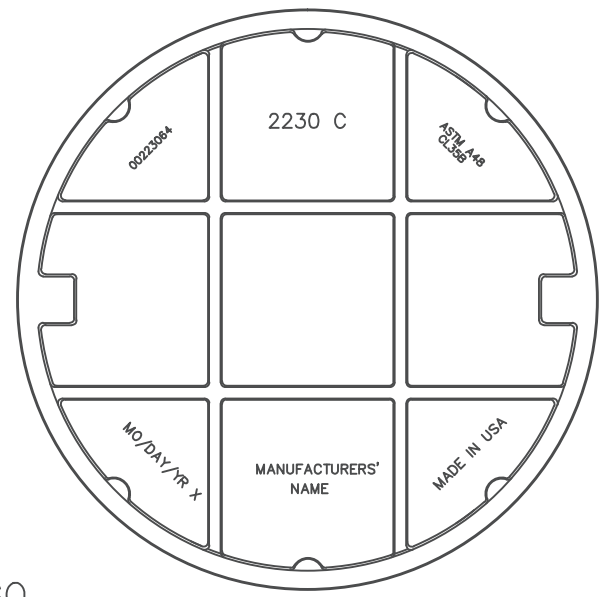

BOTTOM VIEW

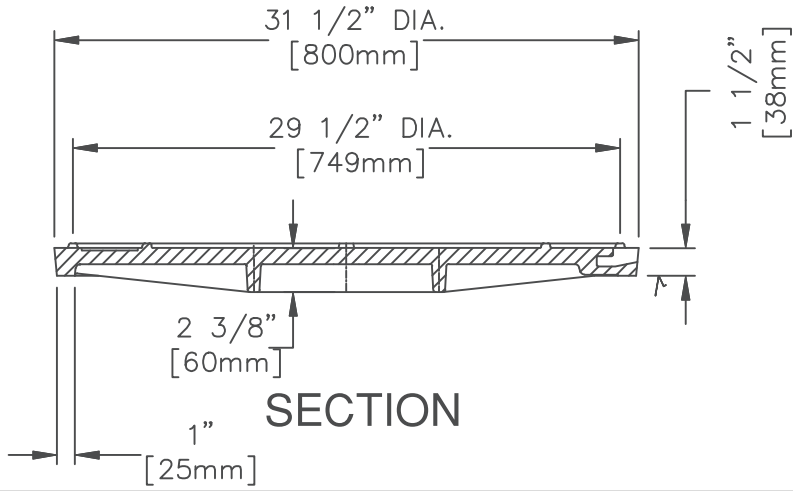

SECTION

NOTES:  
Surface of Manhole Cover to be machined.

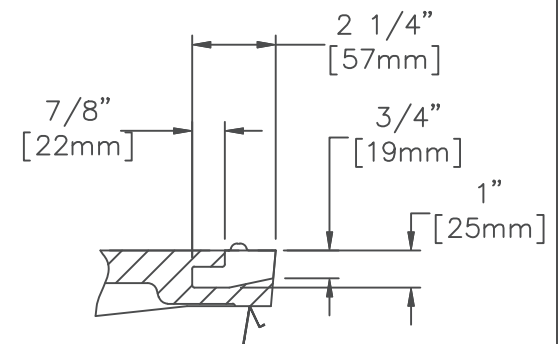

PICKHOLE DETAIL

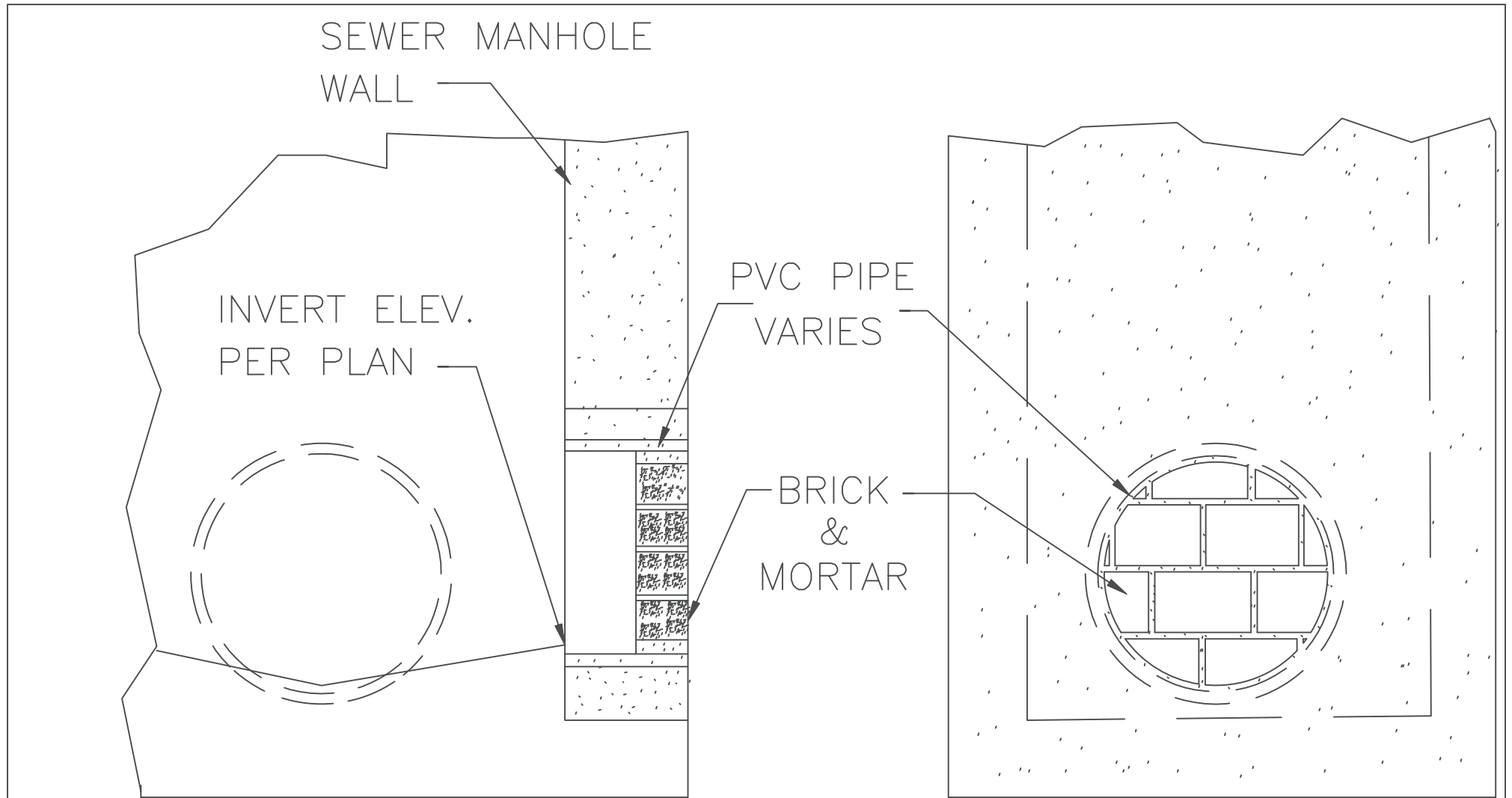

NOTE:

- 1) FOR FUTURE VCP or DUCTILE IRON PIPE INSTALLATION.
- 2) THE PVC DIAMETER SHALL BE THE NEXT SIZE LARGER (2" MINIMUM) THAN THE PROPOSED FUTURE PIPE CONNECTION.

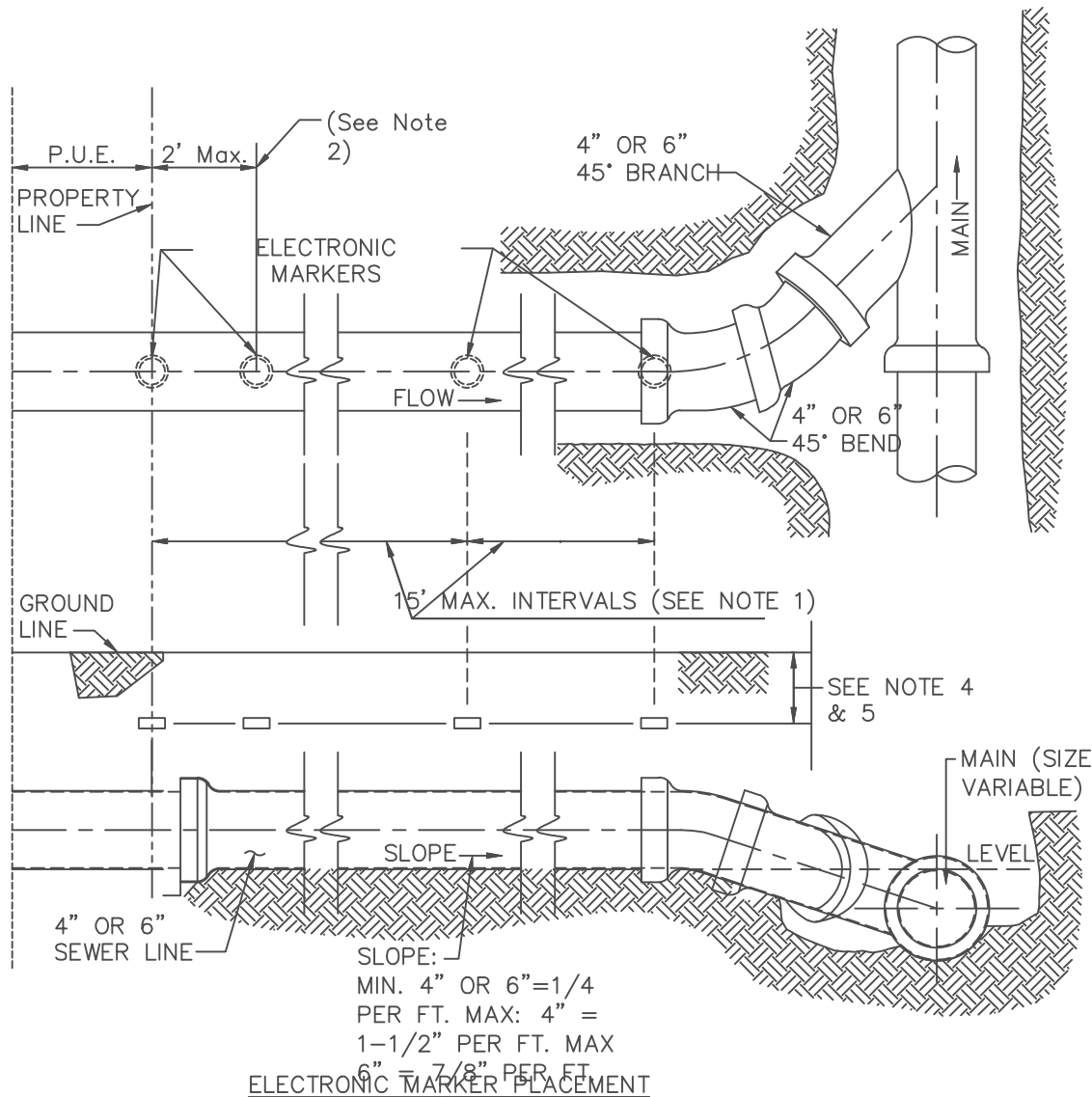

NOTES:

1. Electronic markers shall be installed at the tap, at the property line and at all changes in horizontal direction, if any, over all building connection sewers. Additional markers shall be installed as necessary so that maximum spacing between markers shall not exceed 15 feet.
2. Markers at property line may be installed at up to 2 feet from property line into right-of-way if a fence or other obstruction is anticipated to be constructed on property line.
3. Markers shall be 3M 1253 Full Range (potty seats) capable of detection at up to 8 feet of bury, or equal.
4. Markers shall be installed in a horizontal position centered over the sewer with a 6-inch cushion of soil between pipe and marker when building sewer is 8 feet or less in depth to finish grade.
5. If building connection sewer has over 8 feet of cover, marker shall be positioned over center of sewer and buried at 7 to 8 feet of depth from finish grade.
6. Backfill material within 6-inches of any marker shall sand or well graded material with a maximum aggregate size of 1-inch.
7. Construct building connection sewer at minimum slope if cover will be less than 5 feet at the property line.
8. Aside from wye connection at tap, vertical adjustments of the building connection are not allowed in the right-of-way.
9. All fittings shall be installed in accordance with ASTM D-2321. The Contractor may vary from the drawing to use the appropriate wyes and bends to ensure no misalignment of the pipe and fittings. Joints deflections shall not exceed more than one half of manufacturer's recommendations.
10. End of building connection sewer at property line shall be sealed and marked with 2 x 4" stake extending a minimum of 2 feet above finish grade. The top six inches of the stake shall be painted green.
11. A curb stamp shall be provided per MAG Detail 440-4.

DETAIL NO.  
P1440



**City of Phoenix**  
**STANDARD DETAIL**

SEWER BUILDING CONNECTION  
& ELECTRONIC MARKERS

APPROVED

*[Signature]*  
CITY ENGINEER

12/10/2012  
DATE

DETAIL NO.  
P1440

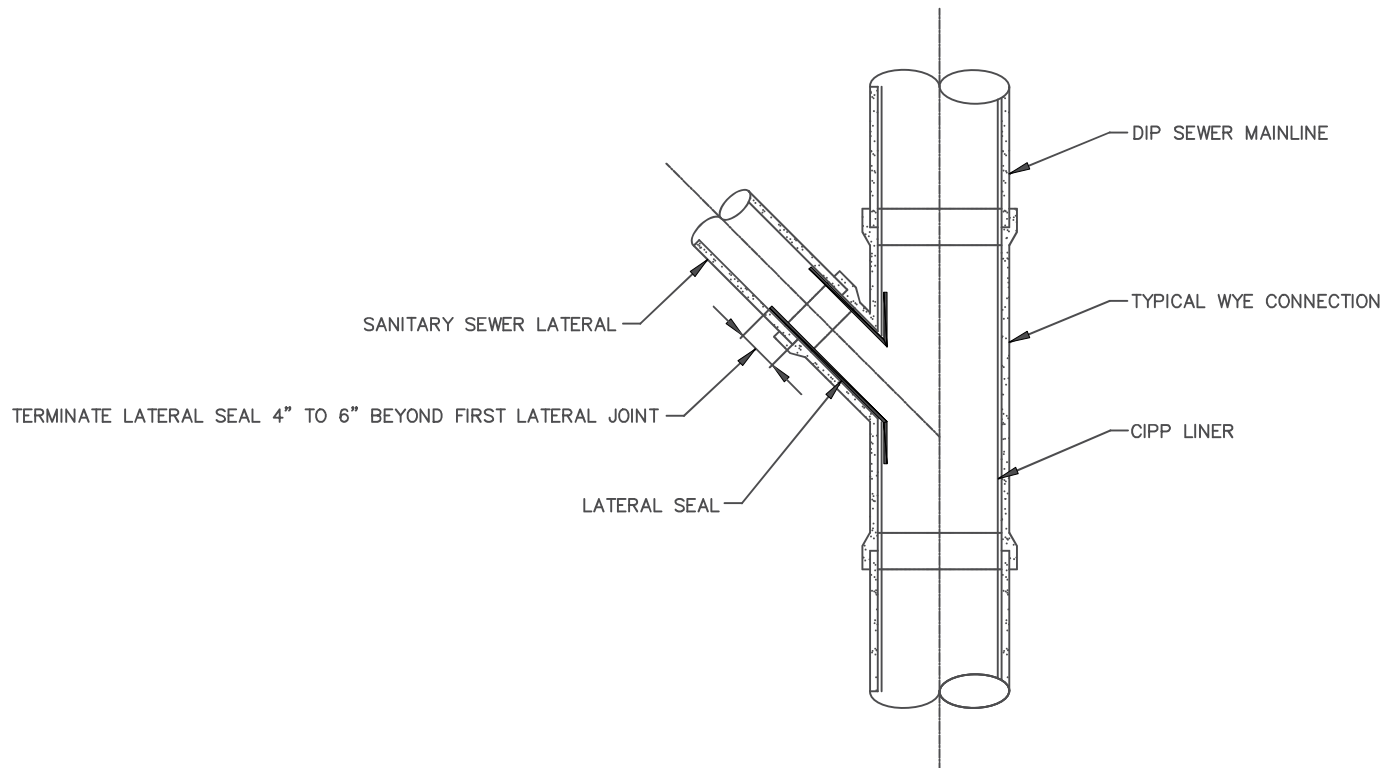

REFER TO CITY SUPPLEMENT TO MAG SPECIFICATIONS  
SECTION 751.6 FOR ADDITIONAL INFORMATION

DETAIL NO.  
P1440-1



**City of Phoenix**  
**STANDARD DETAIL**

SEWER SERVICE CONNECTION LATERAL SEAL

APPROVED

*Evo Huan*  
CITY ENGINEER

12/13/2024  
DATE

DETAIL NO.  
P1440-1

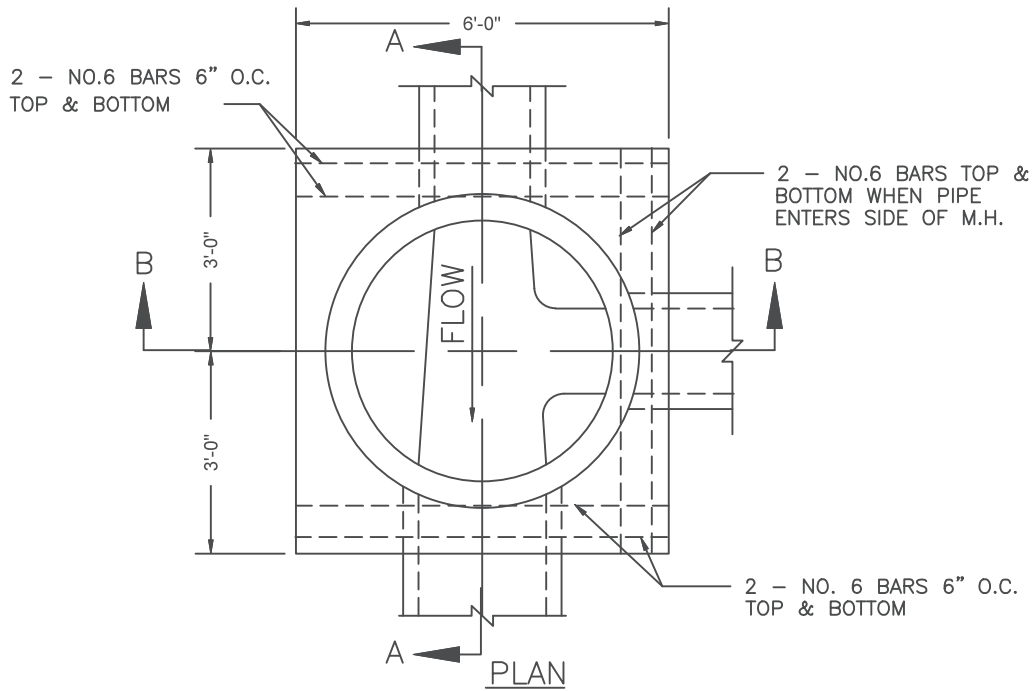

**NOTES**

1. ALL CONCRETE TO BE CLASS "A" PER SECTION 725.
2. MATCH SPRING LINES OF PIPES ENTERING M.H. UNLESS OTHERWISE NOTED.
3. CUT PIPED TO ALLOW SETTING OF 4' DIA. CYLINDRICAL FORM FROM 6" ABOVE MAIN LINE PIPE TO SPRING LINE. CUT PIPE 2" LARGER THAN FORM TO ALLOW 2" CONC. OVER ENDS OF ALL CUT PIPE.
4. INVERT AND BASE OF M.H. TO BE POURED AND INVERT TO BE SHAPED BY HAND TO MAKE SMOOTH TRANSITION FINISH WITH RUBBER FLOAT.
5. CENTER M.H. ON PIPE JOINT WHERE PIPE CHANGES SIZES.
6. BENCH M.H. BASE TO TOP OF LARGEST PIPE.

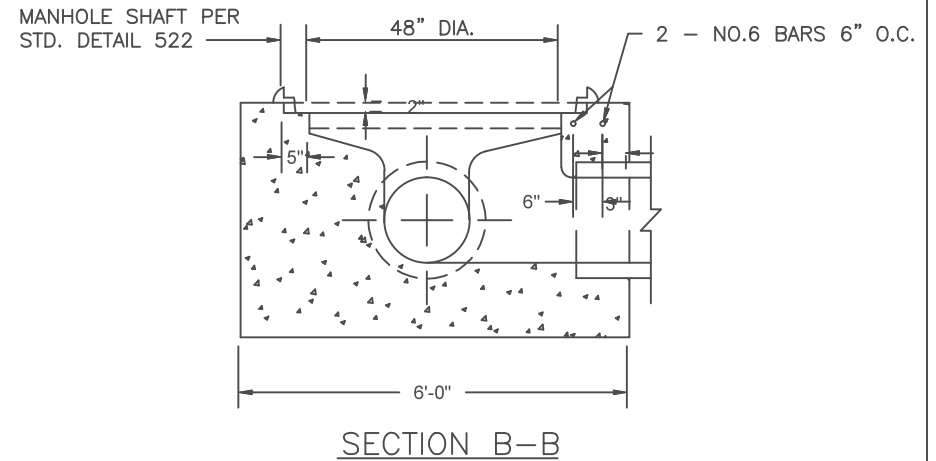
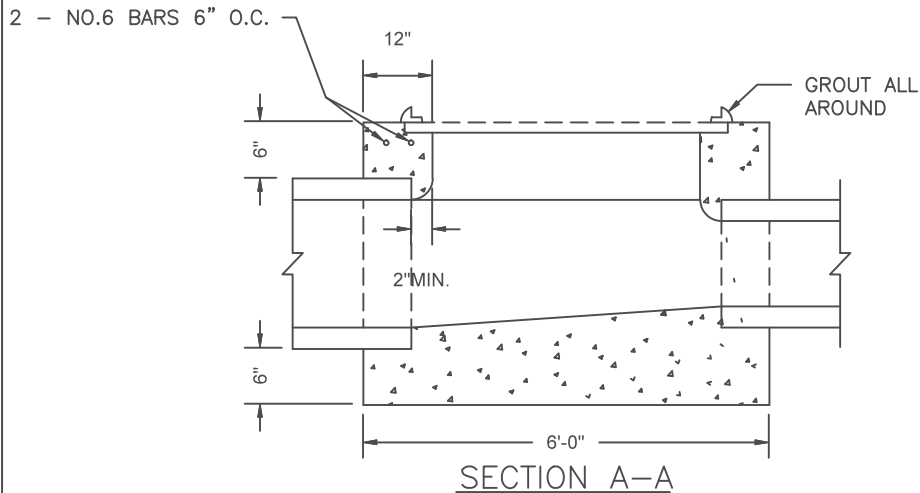

DETAIL NO.  
P1520



**City of Phoenix**  
**STANDARD DETAIL**

STORM DRAIN MANHOLE BASE  
48" & SMALLER

APPROVED

*Kenny Whelan*  
CITY ENGINEER

7/9/92  
DATE

DETAIL NO.  
P1520

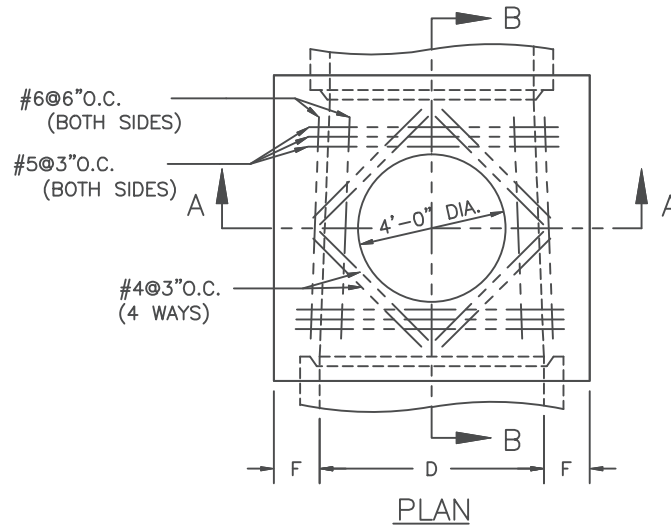

**NOTES:**

1. THICKNESS OF DECK SHALL VARY WHEN NECESSARY TO PROVIDE LEVEL PIPE SEAT BUT SHALL NOT BE LESS THAN 'F'.
2. FLOOR OF MANHOLE SHALL BE STEEL TROWELLED TO SPRING LINE.
3. BODY OF MANHOLE SHALL BE POURED IN ONE CONTINUOUS OPERATION, EXCEPT THAT A CONSTRUCTION JOINT WITH A LONGITUDINAL KEYWAY MAY BE PLACED AT THE SPRING LINE.
4. ALL REINFORCED STEEL SHALL CLEAR FACE OF CONCRETE BY 1-1/2" UNLESS SHOWN OTHERWISE.
5. CONCRETE SHALL BE CLASS 'A'.

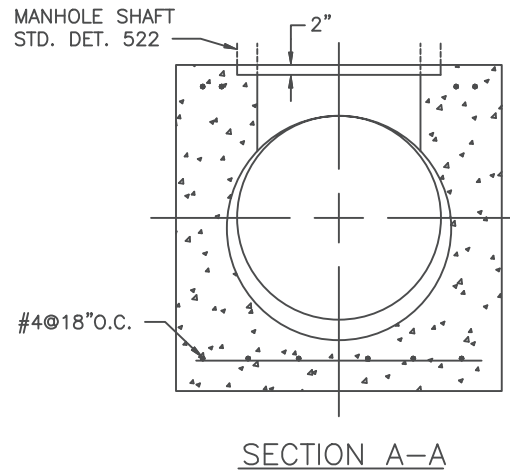
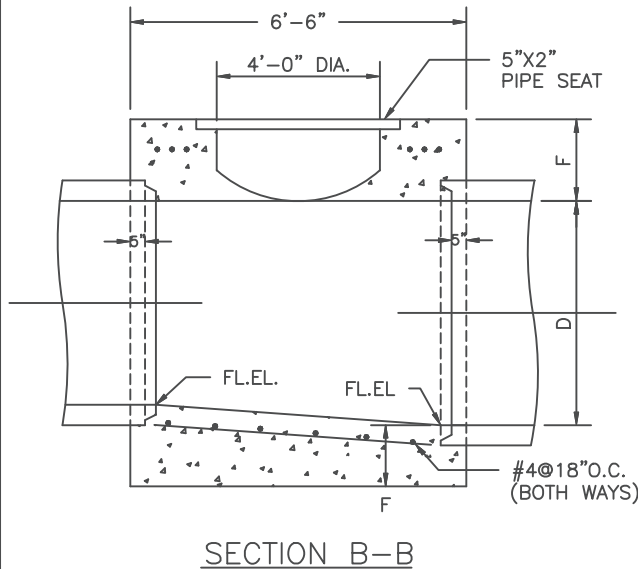

"F" DIMENSION TABLE

D	51"	54"	57"	60"	63"	66"
F	13-3/4"	14-1/2"	15"	15-1/2"	16-1/4"	16-3/4"
D	69"	72"	78"	84"	90"	96"
F	17-1/2"	18"	19-1/4"	20-1/2"	21-3/4"	23"

DETAIL NO.  
P1560



**City of Phoenix**  
**STANDARD DETAIL**

STORM DRAIN MANHOLE BASE TRANSITION  
51" & LARGER

APPROVED

*[Signature]*  
CITY ENGINEER

07/01/2015  
DATE

DETAIL NO.  
P1560



1" DIAMETER  
LIFTING HOLE

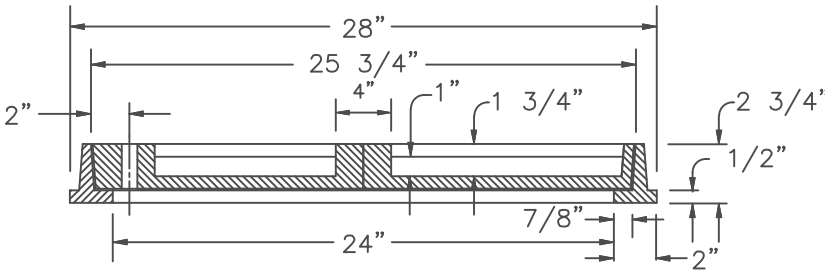
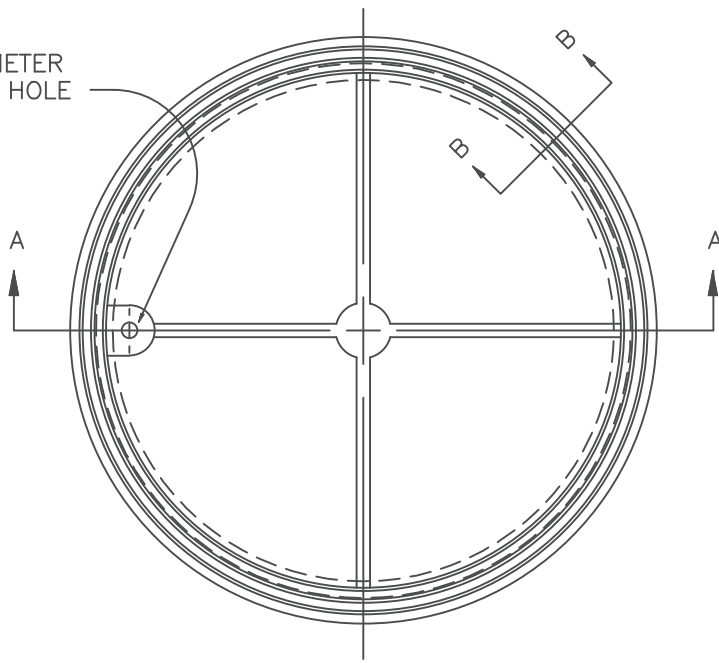

SECTION A - A

CONCRETE  
FILLER

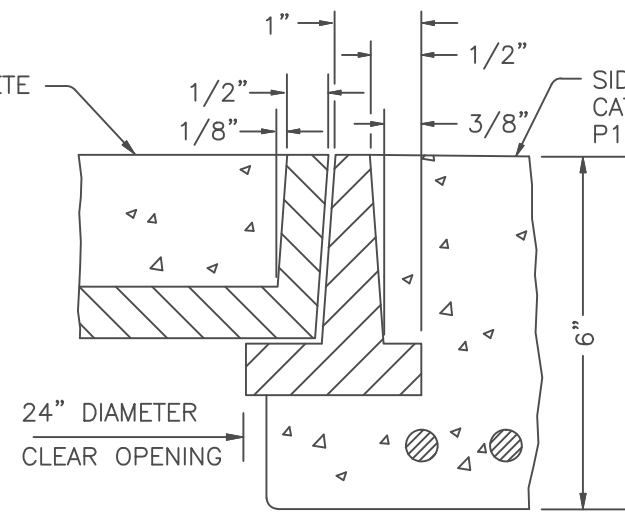

SIDEWALK SLAB FOR  
CATCH BASIN. SEE  
P1569-2 FOR  
MODIFICATION  
WHEN LOCATED  
IN LANDSCAPE  
PARKWAY  
SECTION.

SECTION B - B

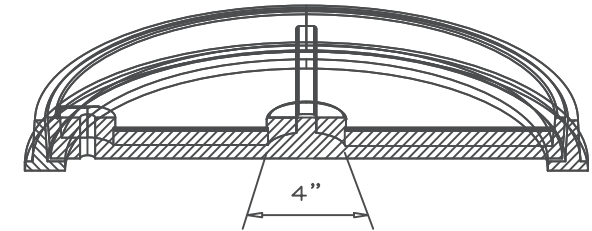

NOTES

1. COVER SHALL BE NON-LOCKING.
2. FRAME AND COVER SHALL BE CAST IRON OR STRUCTURAL STEEL.
3. CATCH BASIN ACCESS FRAME AND COVER IS FOR USE ON NON VEHICULAR TRAFFIC AREAS ONLY.
4. COVER SHALL BE FILLED WITH CONCRETE AND BROOM FINISHED.
5. SMALL VARIATIONS IN DIMENSIONS OR FEATURES OF A MINOR NATURE THAT ARE PART OF THE FOUNDRY'S STANDARD CASTING ARE PERMISSIBLE.

SIZE OF OUTFALL CONDUIT	FRAME ANGLES	SHEAR PIN CLIP ANGLES	SHEAR PINS	ANCHOR BOLTS	HINGE PINS	HINGE ANGLES	HINGE STD. PIPE	HINGE TO FRAME WELDS	ANGLE TO FRAME WELDS	BARRIER BARS PLAIN	NO. OF EQUAL BARRIER BAR SPACES (HORIZ.)	NO. OF EQUAL BARRIER BAR SPACES (VERT.)	H (OUT TO OUT FRAME ANGLES)	W (OUT TO OUT FRAME ANGLES)	A	B
15"	2X2X1/4	4X4X1/4	1-1/8 $\phi$	5/8 $\phi$	1/2" $\phi$	2X2X1/4	3/4"	1/8	1/8	1/2" $\phi$	3	5	34"	20"	SINGLE HINGE CENTERED	
18"	2X2X1/4	4X4X1/4	1-1/8 $\phi$	5/8 $\phi$	1/2" $\phi$	2X2X1/4	3/4"	1/8	1/8	1/2" $\phi$	3	5	34"	20"	SINGLE HINGE CENTERED	
24"	2X2X1/4	4X4X1/4	1-1/8 $\phi$	5/8 $\phi$	1/2" $\phi$	2X2X1/4	3/4"	1/8	1/8	1/2" $\phi$	3	5	34"	20"	SINGLE HINGE CENTERED	
30"	2X2X1/4	4X4X1/4	1-1/8 $\phi$	5/8 $\phi$	1/2" $\phi$	2X2X1/4	3/4"	1/8	1/8	1/2" $\phi$	3	5	34"	20"	SINGLE HINGE CENTERED	
36"	2X2X1/4	4X4X1/4	2-1/8 $\phi$	5/8 $\phi$	1/2" $\phi$	2X2X1/4	3/4"	1/8	1/8	1/2" $\phi$	5	5	42"	32"	SINGLE HINGE CENTERED	
42"	2X2X1/4	4X4X1/4	2-1/8 $\phi$	5/8 $\phi$	1/2" $\phi$	2X2X1/4	3/4"	1/8	1/8	1/2" $\phi$	5	6	42"	32"	2 HINGES 0 0	
48"	3X3X7/16	5X3X1/4	2-1/8 $\phi$	5/8 $\phi$	3/4" $\phi$	2-1/2X 2-2X1/4	1"	1/8	1/8	1/2" $\phi$	5	7	47"	38"	3"	1"
54"	3X3X7/16	5X3X1/4	2-1/8 $\phi$	5/8 $\phi$	3/4" $\phi$	2-1/2X 2-2X1/4	1"	1/8	1/8	1/2" $\phi$	6	8	54"	44"	5"	3"
60"	3X3X7/16	5X3X1/4	2-1/8 $\phi$	5/8 $\phi$	3/4" $\phi$	2-1/2X 2-2X1/4	1"	1/8	1/8	1/2" $\phi$	7	9	60"	50"	9"	4"
66"	3X3X7/16	5X3X1/4	2-1/8 $\phi$	5/8 $\phi$	3/4" $\phi$	2-1/2X 2-2X1/4	1"	1/8	1/8	1/2" $\phi$	8	10	66"	56"	11"	6"
72"	4X4X5/8	5X3X1/4	2-3/16 $\phi$	5/8 $\phi$	1" $\phi$	3X3X3/8	1-1/4"	1/8	1/8	1/2" $\phi$	9	11	73"	62"	15"	7"
78"	4X4X5/8	5X3X1/4	2-3/16 $\phi$	5/8 $\phi$	1" $\phi$	3X3X3/8	1-1/4"	1/8	1/8	1/2" $\phi$	10	11	79"	68"	17"	9"
84"	4X4X5/8	5X3X1/4	2-3/16 $\phi$	5/8 $\phi$	1" $\phi$	3X3X3/8	1-1/4"	1/8	1/8	1/2" $\phi$	11	13	86"	74"	21"	10"
90"	4X4X5/8	5X3X1/4	2-3/16 $\phi$	5/8 $\phi$	1" $\phi$	3X3X3/8	1-1/4"	1/8	1/8	1/2" $\phi$	12	13	92"	80"	23"	12"
96"	4X4X5/8	5X3X1/4	2-3/16 $\phi$	5/8 $\phi$	1" $\phi$	3X3X3/8	1-1/4"	1/8	1/8	1/2" $\phi$	12	14	98"	86"	29"	12"
108"																
120"																

DETAIL NO.  
P1562



**City of Phoenix**  
**STANDARD DETAIL**

BARRIER SPECIFICATION SCHEDULE

APPROVED

*Maria S. Demando*  
CITY ENGINEER

8/8/03  
DATE

DETAIL NO.  
P1562

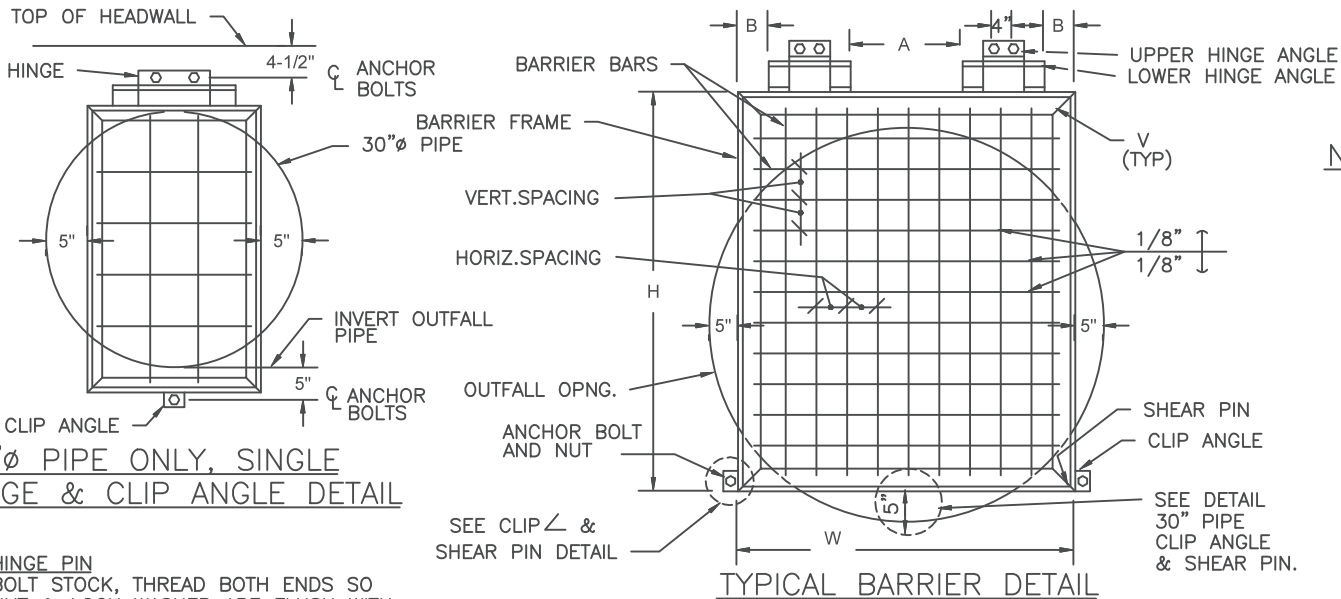

**NOTES:**

1. ALL SHEAR PIN ANGLES SHALL FIT SNUGLY AND TRULY FACE TO FACE. COVER WITH WATERPROOF GREASE PRIOR TO INSTALLATION OF PIN.
2. GALVANIZE ALL FERROUS PARTS AFTER FABRICATION.
3. THE SHEAR PIN HOLES IN THE ANGLE SHALL BE DRILLED FOR A TIGHT FIT OF THE SHEAR PINS.
4. FRAME AND HINGE ANGLES SHALL HAVE THE OUTSTANDING LEGS OUT FOR OUTLETS.
5. ALL ANCHOR BOLTS SHALL BE 5/8"Ø ANCHOR BOLTS EMBEDDED 4"(MIN.) INTO EPOXY GROUT.
6. ALL SHEAR PINS ARE TO BE PEENED BOTH ENDS AFTER INSTALLATION.
7. SHEAR PIN MATERIAL SHALL BE COMMERCIAL PURE ALUMINUM WIRE, ALLOY 1100, TEMPER O, FEDERAL SPEC. QQ-A-411.
8. SEE BARRIER SCHEDULE, DET. P1562 FOR VARIABLE DIMENSIONS.
9. COVER ALL MOVABLE CONTACT SURFACE WITH A COAT OF WATERPROOF GREASE PRIOR TO INSTALLATION.

**HINGE PIN**  
BOLT STOCK, THREAD BOTH ENDS SO NUT & LOCK WASHER ARE FLUSH WITH LOWER ∟, UPSET OR DAMAGE EXPOSED THREADS. COAT PIN WITH WATERPROOF GREASE BEFORE INSTALLATION.

FILL WITH EPOXY GROUT ALL AROUND.

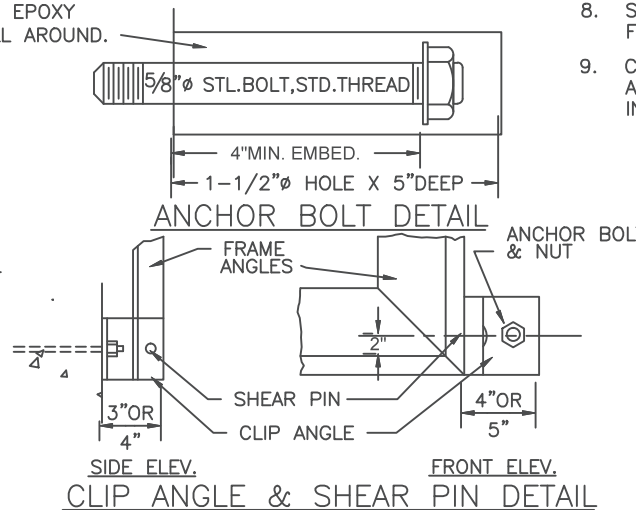
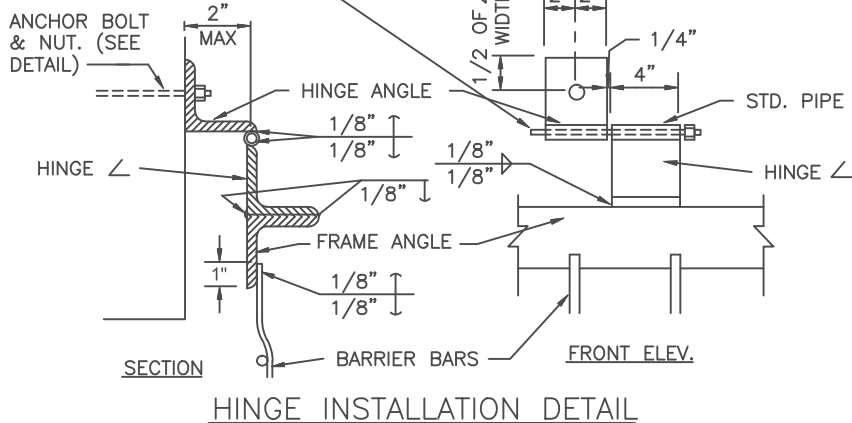

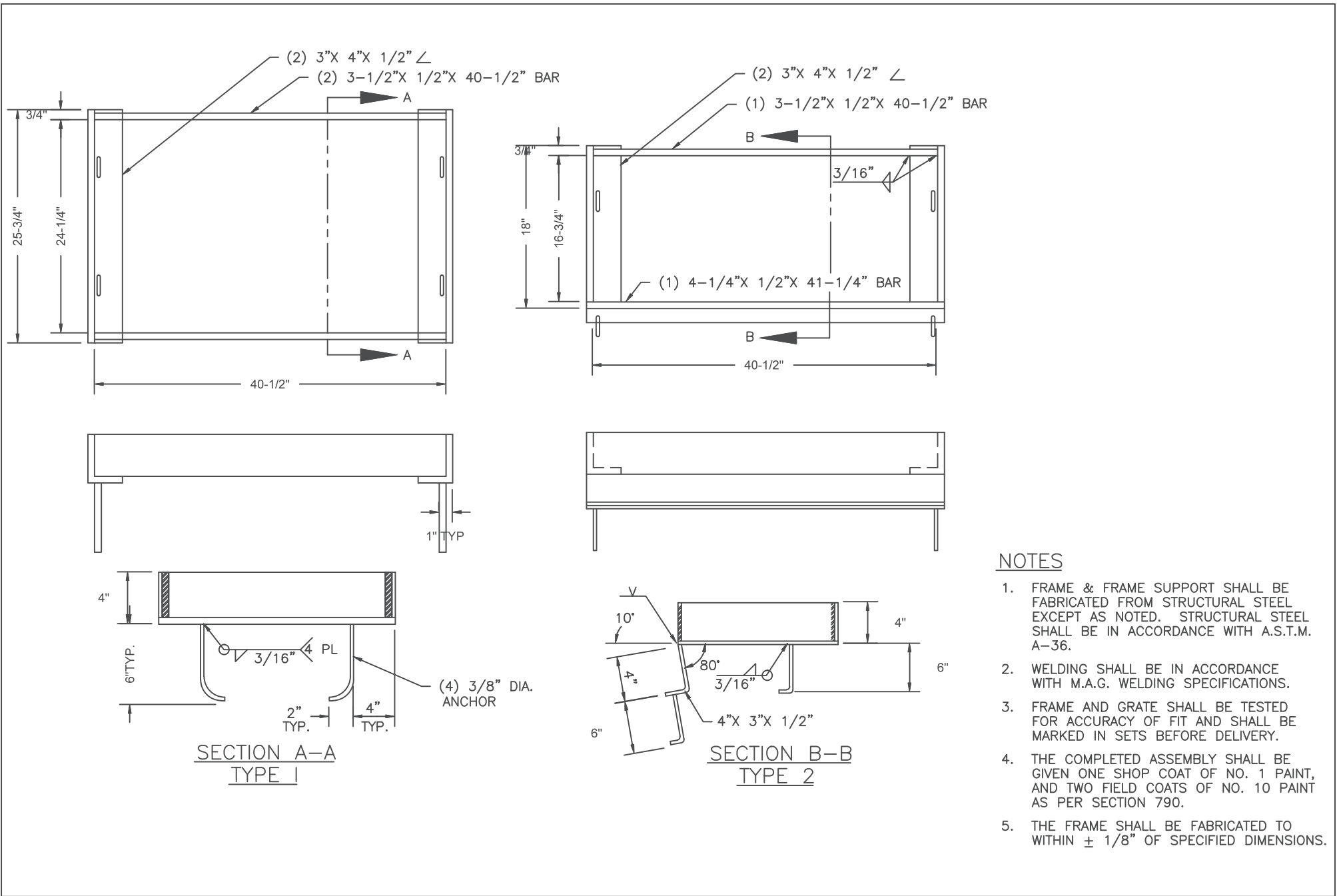

**NOTES**

1. FRAME & FRAME SUPPORT SHALL BE FABRICATED FROM STRUCTURAL STEEL EXCEPT AS NOTED. STRUCTURAL STEEL SHALL BE IN ACCORDANCE WITH A.S.T.M. A-36.
2. WELDING SHALL BE IN ACCORDANCE WITH M.A.G. WELDING SPECIFICATIONS.
3. FRAME AND GRATE SHALL BE TESTED FOR ACCURACY OF FIT AND SHALL BE MARKED IN SETS BEFORE DELIVERY.
4. THE COMPLETED ASSEMBLY SHALL BE GIVEN ONE SHOP COAT OF NO. 1 PAINT, AND TWO FIELD COATS OF NO. 10 PAINT AS PER SECTION 790.
5. THE FRAME SHALL BE FABRICATED TO WITHIN ± 1/8" OF SPECIFIED DIMENSIONS.

(7) 1/2" DIA. X 24", TRANSVERSE RODS, 5" ON CENTER,  
FLUSH WITH GRATE SURFACE.

(2) 2-1/2" X 1/4" X 24", END BARS

(14) 3-1/2" X 1/2" X 39-1/2" BEARING BAR  
APPROXIMATELY 1-7/8" ON CENTER.

3/16"  EACH BAR & ROD

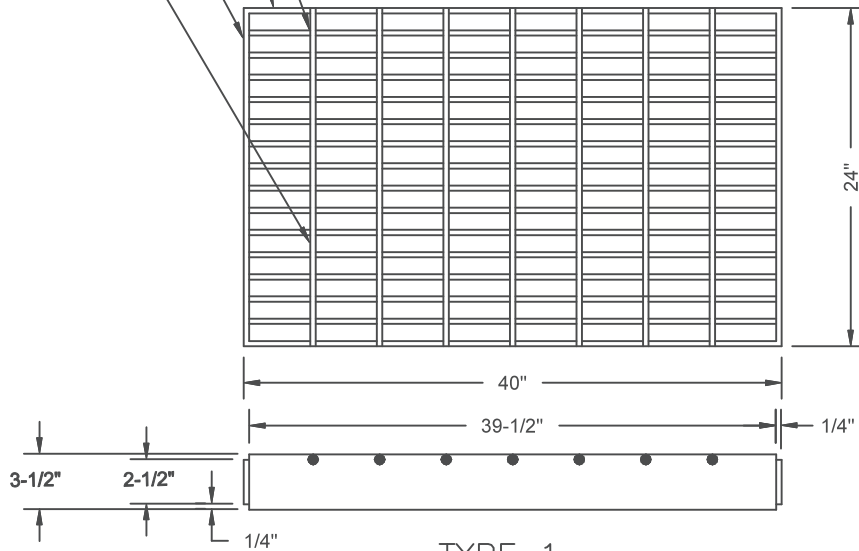

TYPE 1

(7) 1/2" DIA. X 16-1/2", TRANSVERSE RODS, 5" ON CENTER  
FLUSH WITH GRATE SURFACE.

(2) 2-1/2" X 1/4" X 16-1/2" END BARS

(10) 3-1/2" X 1/2" X 39-1/2" BEARING BAR  
APPROXIMATELY 1-7/8" ON CENTER.

3/16"  EACH BAR & ROD

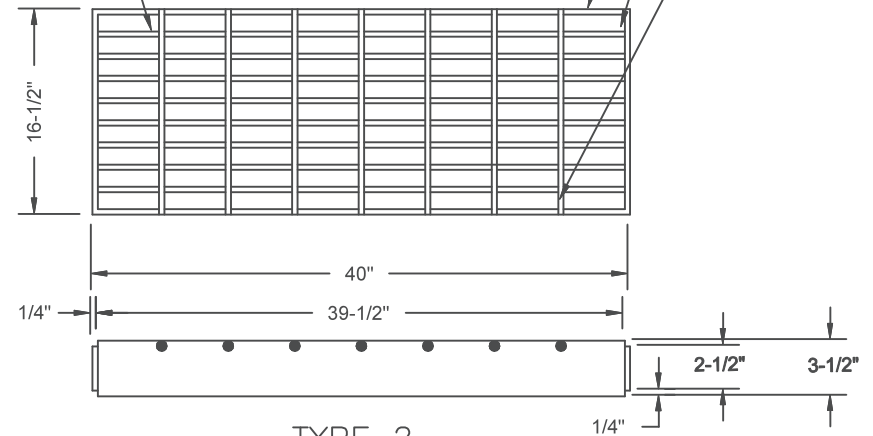

TYPE 2

NOTES:

1. ALL STEEL SHALL BE IN ACCORDANCE WITH A.S.T.M. A-36.
2. WELDING SHALL BE IN ACCORDANCE WITH A.W.S. SPECIFICATIONS.
3. FRAME AND GRATE SHALL BE TESTED FOR ACCURACY OF FIT AND SHALL BE MARKED IN SETS BEFORE DELIVERY.
4. THE COMPLETED ASSEMBLY SHALL BE GIVEN ONE SHOP COAT OF NO. 1 PAINT AND TWO FIELD COATS OF NO. 10 PAINT AS PER SECTION 790.
5. THE GRATE SHALL BE FABRICATED TO WITHIN 1/8" OF SPECIFIED DIMENSIONS.
6. TYPE 1 AND TYPE 2 GRATES, INSTALLED IN GRATE FRAMES PER STANDARD DETAIL P1564, ARE BICYCLE FRIENDLY AND MAY BE USED WITHIN BICYCLE FACILITIES WITH BEARING BARS ORIENTED PARALLEL TO THE DIRECTION OF TRAVEL.
7. TYPE1 AND TYPE 2 GRATES ARE NOT PEDESTRIAN FRIENDLY AND SHALL NOT BE USED IN PEDESTRIAN TRAVELED WAYS.

DETAIL NO.  
P1565



**City of Phoenix**  
**STANDARD DETAIL**

CATCH BASIN GRATES

APPROVED

  
CITY ENGINEER

07/01/2015  
DATE

DETAIL NO.  
P1565

C=6" STD. CURB, M=2"  
 C=5" STD. CURB, M=3"  
 C=4" STD. CURB, M=4"

FOR INLET OPENING, SEE  
 DET. P1574

SET EDGE OF ANGLE  
 IN PLANE OF CURB

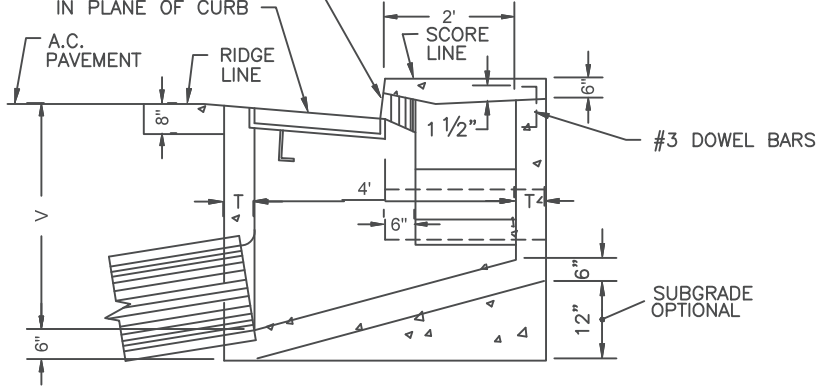

SECTION A-A

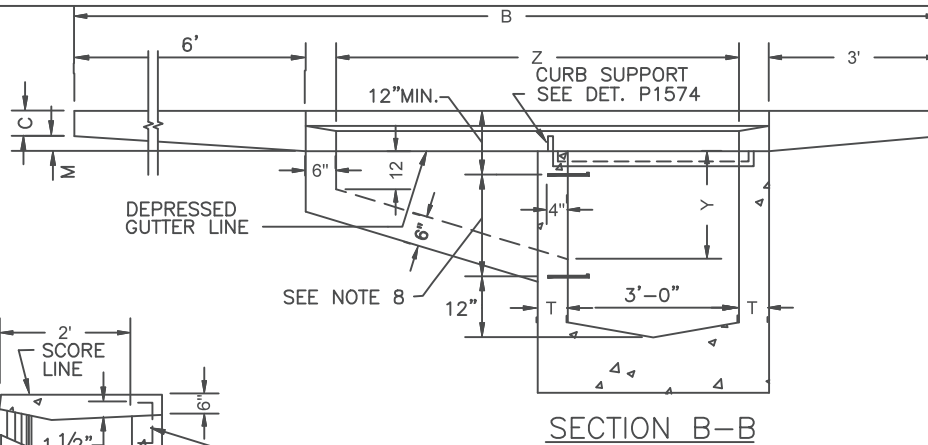

SECTION B-B

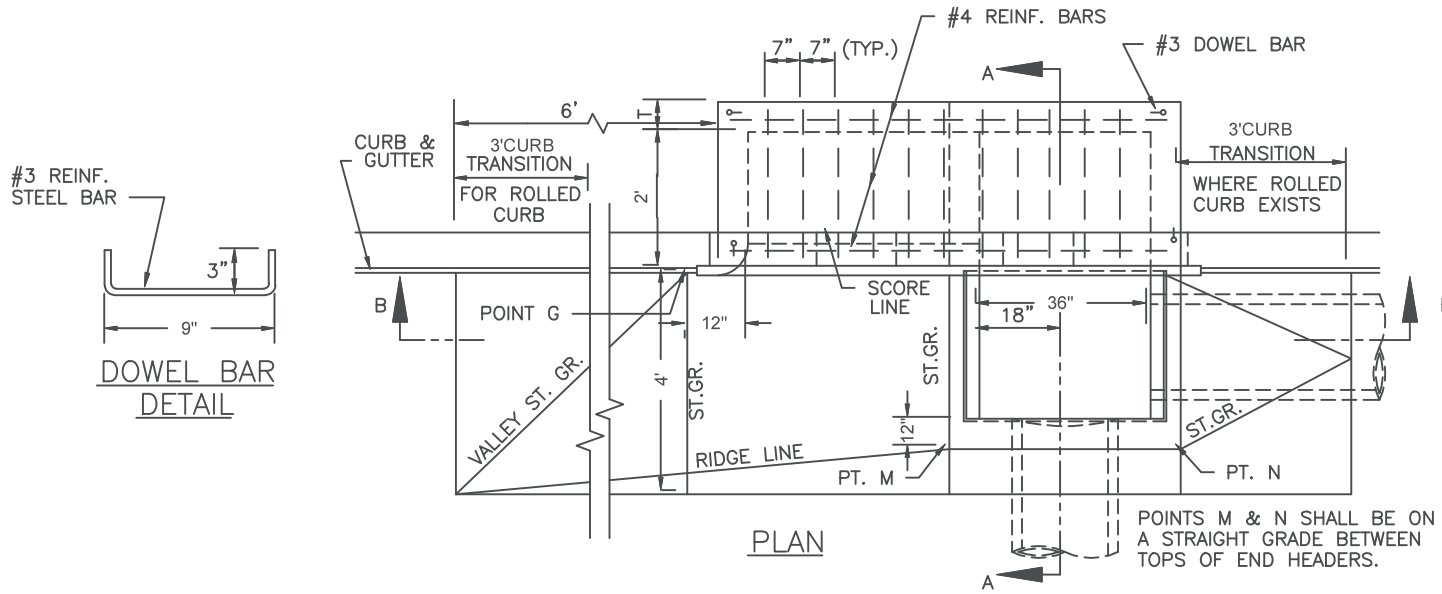

PLAN

**CATCH BASIN WALL THICKNESS**  
 T=6" IF V IS 4' OR LESS  
 T=8" IF V IS 4' TO 8'  
 IF V EXCEEDS 8' SPECIAL DESIGN IS REQUIRED  
 V=4'-0" UNLESS OTHERWISE NOTED

**NOTES:**

1. DIMENSIONS 'Z' SHALL EQUAL 7' OR 14' TYPES ARE DESIGNATED AS FOLLOWS: TYPE J7, (Z=7', Y=24", B=17') TYPE J14, (Z=14', Y=30", B=24')
2. ALL CONCRETE SHALL BE CLASS 'A'.
3. ALL REINFORCING STEEL SHALL BE DEFORMED BARS AND SHALL CONFORM TO A.S.T.M. SPEC. 615.
4. CONNECTOR PIPES MAY BE PLACED IN ANY WALL BENEATH THE GRATE AS PER PLANS.
5. FLOOR OF BASIN SHALL BE TROWELLED TO A HARD SMOOTH SURFACE AND SHALL SLOPE FROM ALL DIRECTIONS TO OUTLET.
6. CONSTRUCTION DRAINS SHALL BE INSTALLED WHEN NOTED. (SEE DET. P1575)
7. DO NOT SPECIFY THIS DETAIL FOR USE IN A MAJOR STREET.
8. THE FRAME SHALL BE DET. P1564, TYPE I AND THE GRATE SHALL BE DET. P1565, TYPE I.
9. INSTALL ONE CITY FURNISHED POLLUTION AWARENESS MARKER (PAM) AT EACH CATCH BASIN, AS DIRECTED BY THE ENGINEER.

DETAIL NO.  
 P1566



**City of Phoenix**  
**STANDARD DETAIL**

CATCH BASIN COMBINATION  
 TYPE "J" WITH CONCRETE APRON

APPROVED

*[Signature]*  
 CITY ENGINEER

12/10/2012  
 DATE

DETAIL NO.  
 P1566

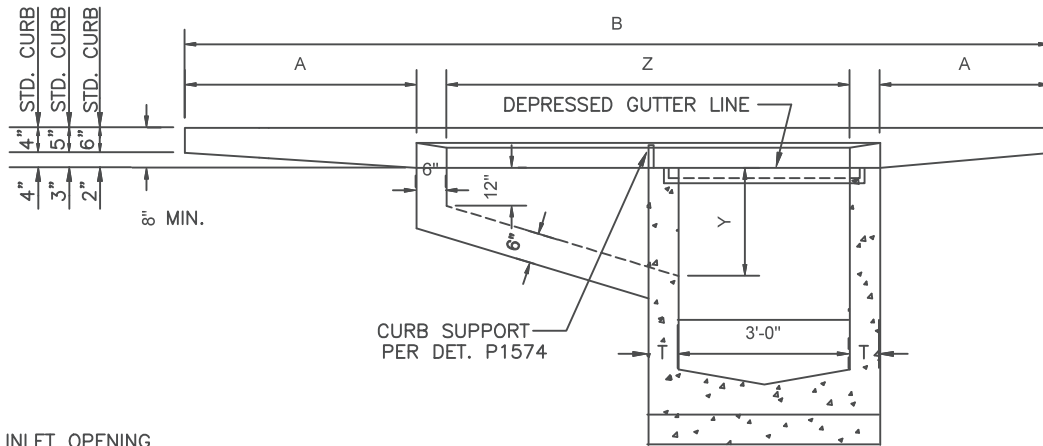

DEPRESSED GUTTER TRANSITION			
CURB HEIGHT	A	B	
		K7	K14
4"	3'-3"	14'-6"	21'-6"
5"	2'-6"	13'	20'
6"	1'-9"	11'-6"	18'-6"

**NOTES:**

1. DIMENSION Z SHALL EQUAL 7' OR 14' TYPES ARE DESIGNATED AS FOLLOWS:  
 Δ TYPE K7 (Z=7', Y=24")  
 Δ TYPE K14 (Z=14', Y=30")
2. ALL CONCRETE SHALL BE CLASS 'A'.
3. ALL REINFORCING STEEL SHALL BE DEFORMED BARS AND SHALL CONFORM TO A.S.T.M. SPECIFICATION 615.
4. CONNECTOR PIPES MAY BE PLACED IN ANY WALL BENEATH THE GRATE AS PER PLANS.
5. FLOOR OF BASIN SHALL BE TROWELLED TO A HARD SMOOTH SURFACE AND SHALL SLOPE FROM ALL DIRECTIONS TO OUTLET.
6. CONSTRUCTION DRAINS SHALL BE INSTALLED WHEN NOTED. (SEE DET. P1575).
7. ACCESS FRAME AND COVER PER DET. P1561.
- \* 8. THE FRAME SHALL BE DET. P1564, TYPE 2 AND THE GRATE SHALL BE DET. P1565, TYPE 2.
9. INSTALL ONE CITY FURNISHED POLLUTION AWARENESS MARKER (PAM) AT EACH CATCH BASIN, AS DIRECTED BY THE ENGINEER.

**SECTION B-B**

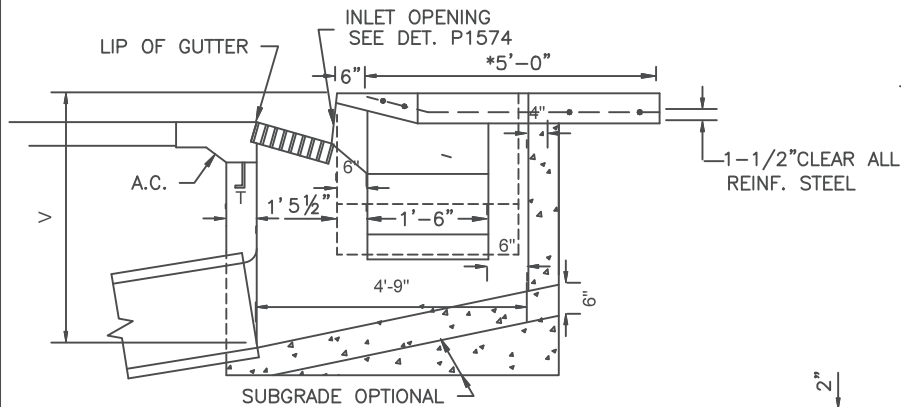

**SECTION A-A**

\*4'-0" IN LOCATIONS WHERE 4' S/W IS REQ'D

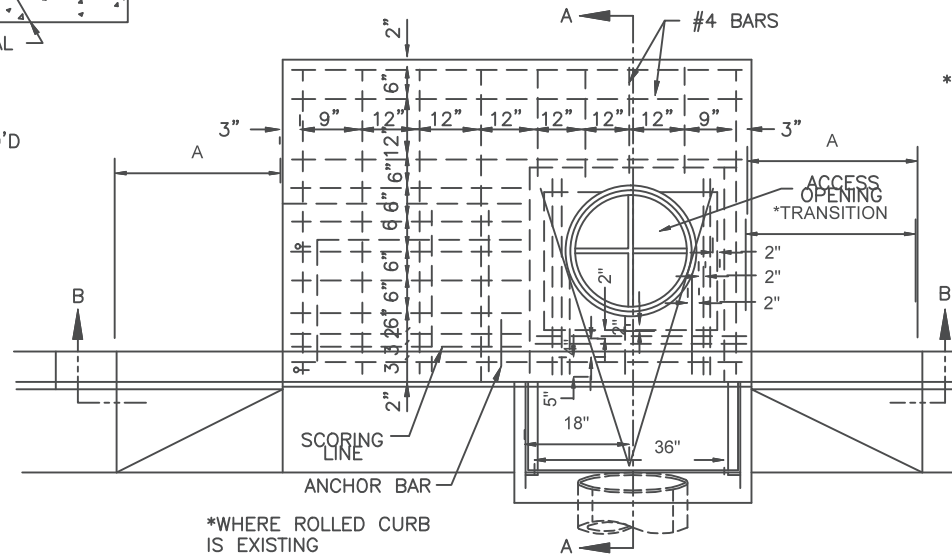
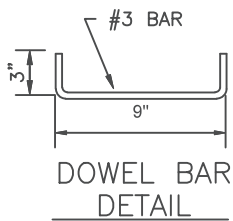

\*WHERE ROLLED CURB IS EXISTING

**CATCH BASIN WALL THICKNESS**  
 T=6" IF V IS 4' OR LESS  
 T=8" IF V IS 4' TO 10'  
 IF V EXCEEDS 8' SPECIAL DESIGN IS REQUIRED  
 V=4'-0" UNLESS OTHERWISE NOTED.

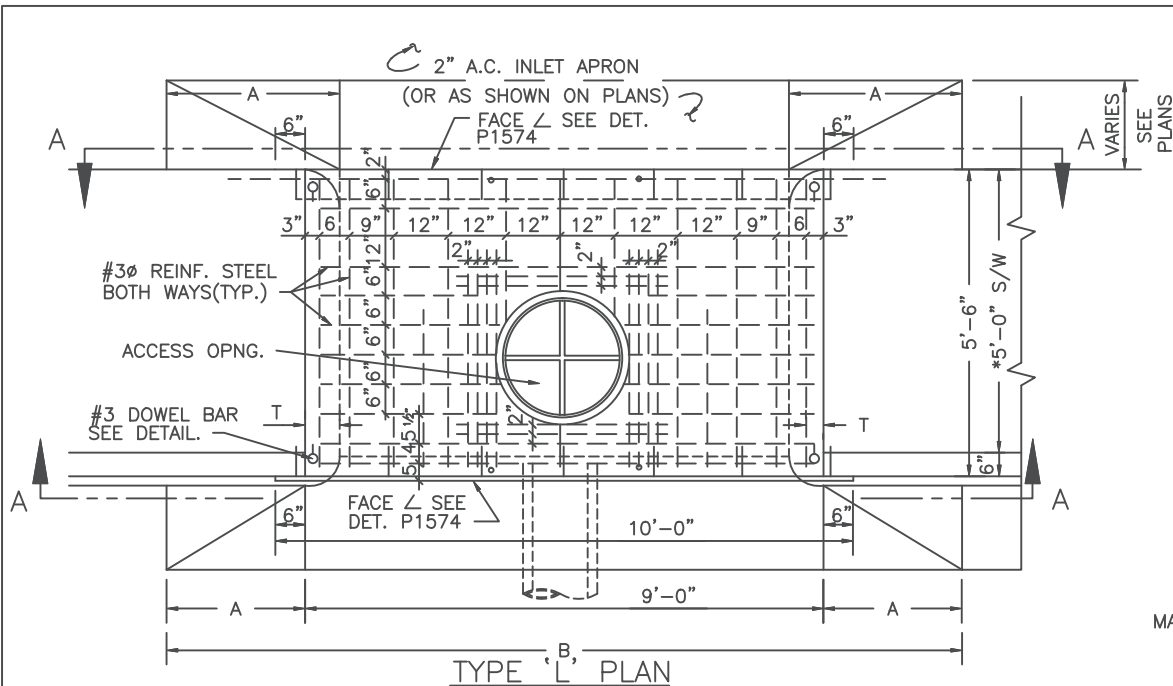

**NOTES:**

1. ALL CONCRETE SHALL BE CLASS 'A'.
2. ALL REINFORCING STEEL SHALL BE DEFORMED BARS AND SHALL CONFORM TO A.S.T.M. SPECIFICATION 615.
3. CONNECTOR PIPES MAY BE PLACED IN ANY WALL AS PER PLANS.
4. FLOOR OF BASIN SHALL BE TROWELLED TO A HARD, SMOOTH SURFACE AND SHALL SLOPE FROM ALL DIRECTIONS TO OUTLET.
5. CONSTRUCTION DRAINS SHALL BE INSTALLED WHEN SPECIFIED. (SEE DET. P1575.)
6. ACCESS FRAME AND COVER PER DET. P1561.
7. INSTALL ONE CITY FURNISHED POLLUTION AWARENESS MARKER (PAM) AT EACH CATCH BASIN, AS DIRECTED BY THE ENGINEER.

\* TO BE 4'-0" IN LOCATIONS WHERE 4' S/W IS REQUIRED.

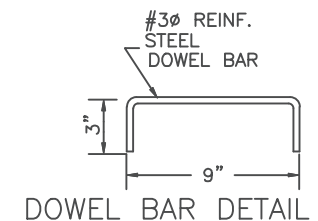
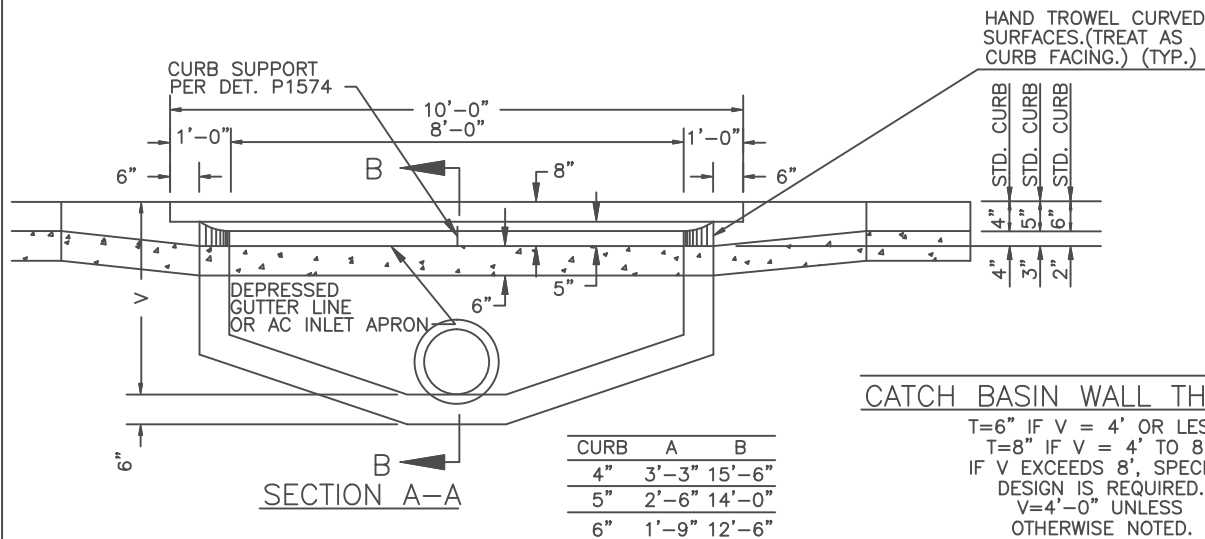
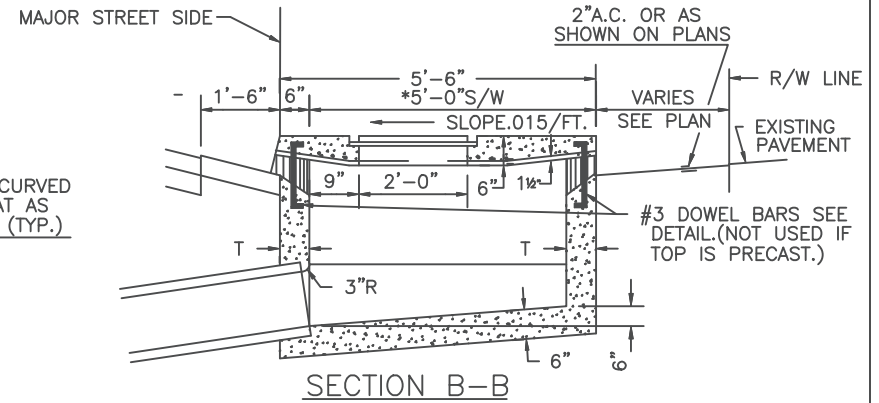



GUTTER TRANSITION	
CURB HEIGHT	DIM 'A'
4"	3'-3"
5"	2'-6"
6"	1'-9"

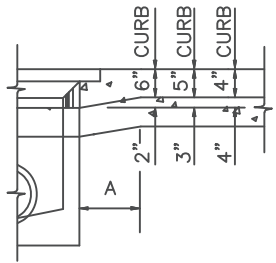

DEPRESSED GUTTER

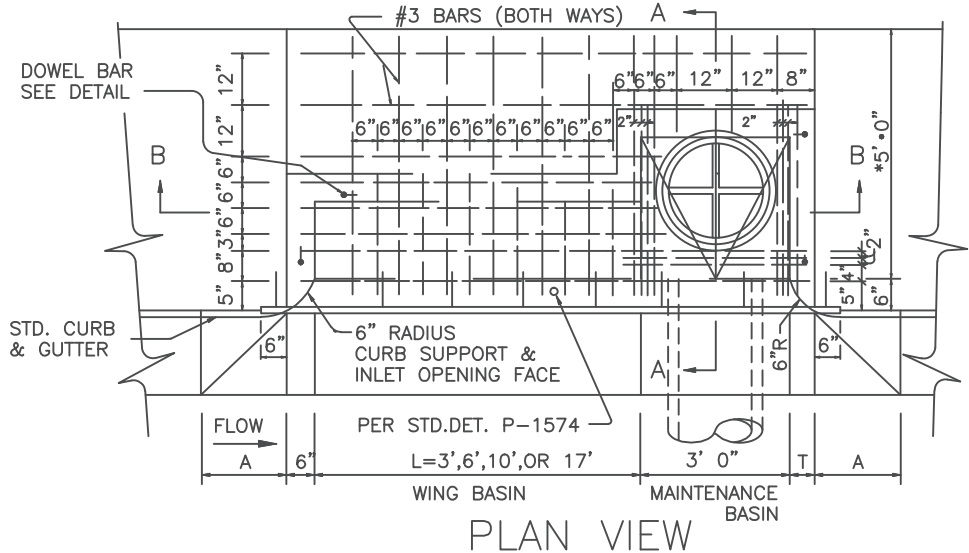

PLAN VIEW

TRANSITION (BOTH SIDES)

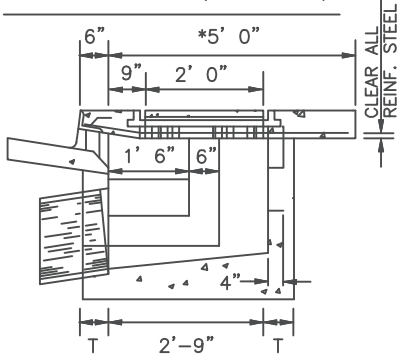

SECTION A - A

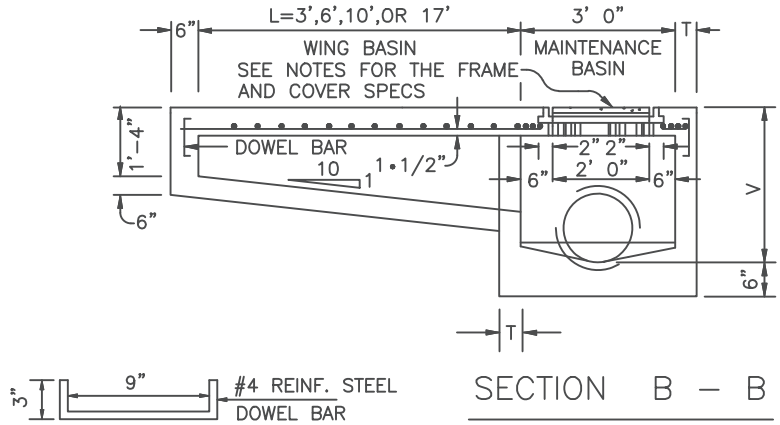

SECTION B - B

DOWEL BAR  
DETAIL

NOTES

1. TYPES ARE DESIGNATED AS FOLLOWS:  
'M'.. NO WING, 'M-1'.. ONE WING,  
'M-2'.. TWO WINGS.
2. ALL CONCRETE SHALL BE CLASS 'A'.
3. ALL REINFORCING STEEL SHALL BE DEFORMED BARS AND SHALL CONFORM TO A.S.T.M. SPECIFICATION 615.
4. CONNECTOR PIPES SHALL BE PLACED IN THE APPROPRIATE WALL OF THE MAINTENANCE BASIN.
5. FLOOR OF BASIN SHALL BE TROWELLED TO A HARD, SMOOTH SURFACE AND SHALL SLOPE FROM ALL DIRECTIONS TO OUTLET.
6. CONSTRUCTION DRAINS SHALL BE INSTALLED IN WHEN NOTED. (SEE DET. P-1575.)
7. LOCATE WING BASIN ON UPSTREAM SIDE OF MAINTENANCE BASIN FOR TYPE M-1. WING BASINS FOR TYPE M-2 SHALL BE BOTH SIDES OF MAINTENANCE BASIN.
8. ACCESS FRAME AND COVER PER DET. P-1561
9. INSTALL ONE CITY FURNISHED POLLUTION AWARENESS MARKER (PAM) AT EACH CATCH BASIN, AS DIRECTED BY THE ENGINEER.

CATCH BASIN WALL THICKNESS
T = 6" IF V = 4' OR LESS
T = 8" IF V = 4' TO 8'
(IF V EXCEEDS 8', SPECIAL DESIGN IS REQUIRED.)
L = 0' UNLESS SPECIFIED ON THE PLANS
V = 4'-0" MIN. UNLESS OTHERWISE NOTED
*4'-0" IN LOCATIONS WHERE 4' SIDEWALK IS REQ'D.

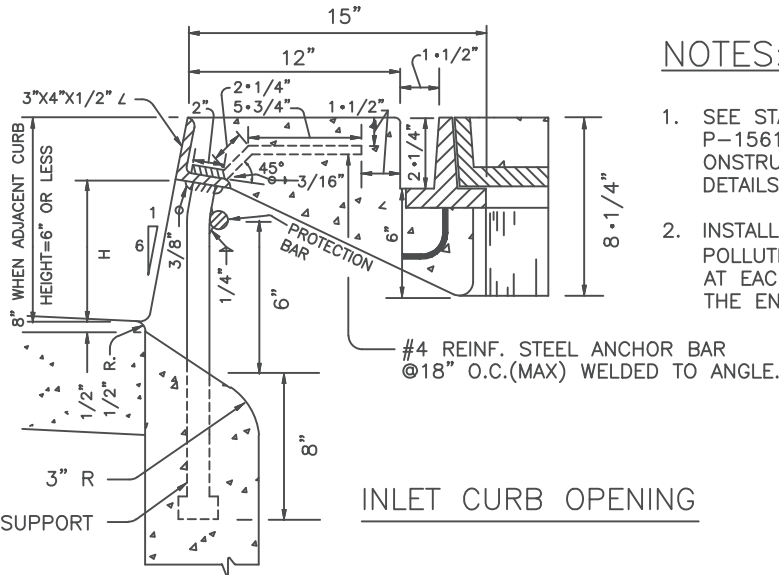
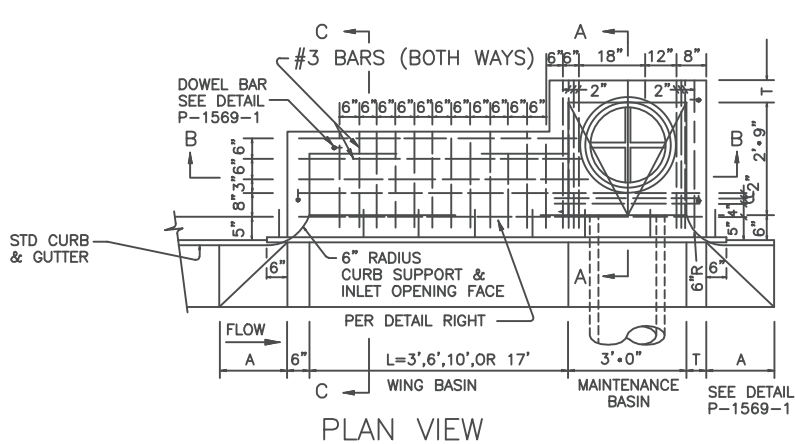

**NOTES:**

1. SEE STANDARD DETAILS P-1569-1, P-1561, AND P-1574 FOR CONSTRUCTION NOTES AND ADDITIONAL DETAILS.
2. INSTALL ONE CITY FURNISHED POLLUTION AWARENESS MARKER (PAM) AT EACH CATCH BASIN, AS DIRECTED BY THE ENGINEER.

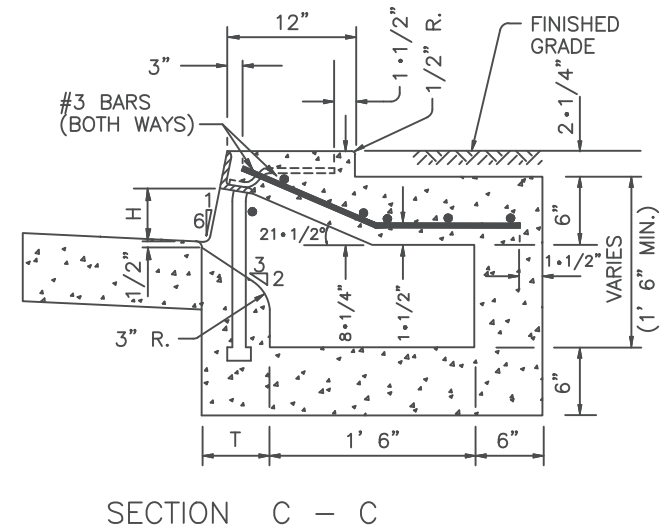
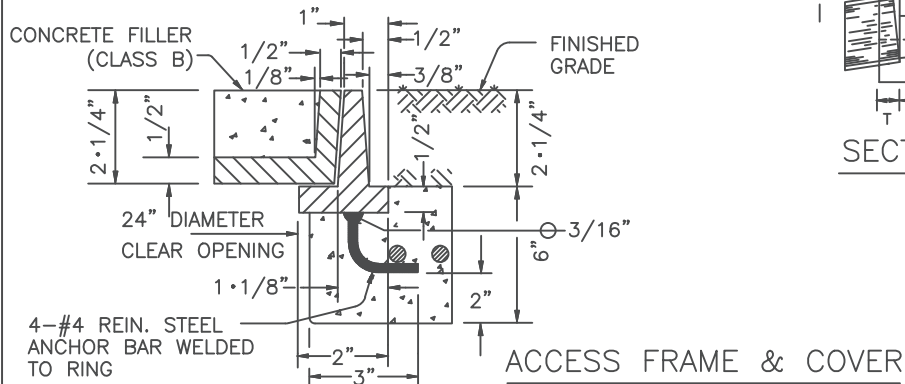
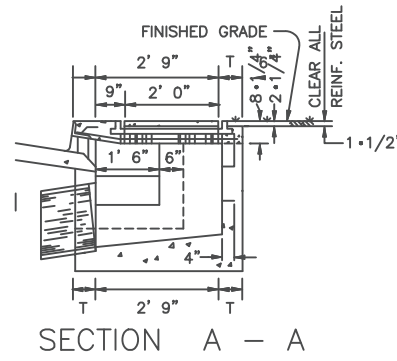
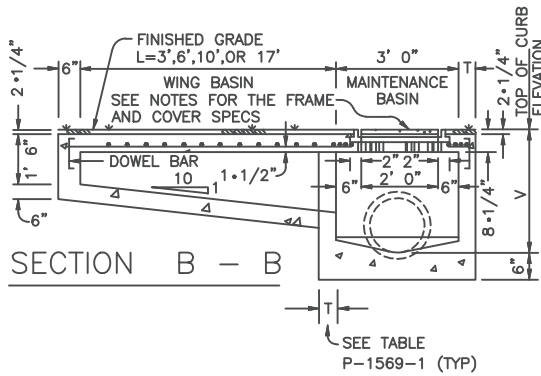

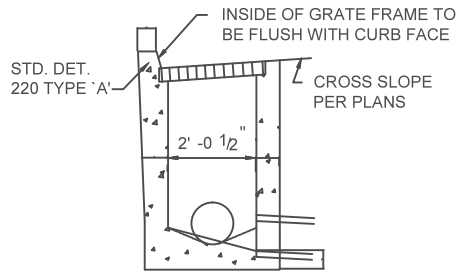

**'N' CATCH BASIN IN  
VERTICAL CURB & GUTTER**

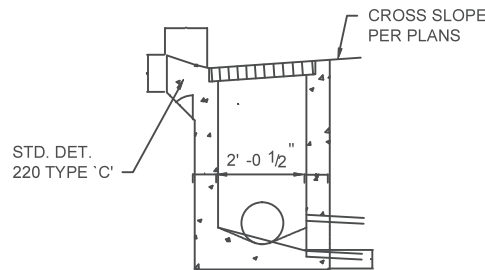

**'N' CATCH BASIN IN  
ROLL CURB & GUTTER**

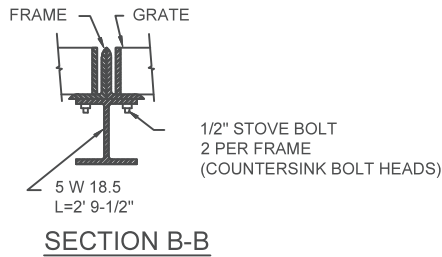

GRATE SUPPORT FOR  
DOUBLE & TRIPLE ONLY  
SEE SECT. B-B

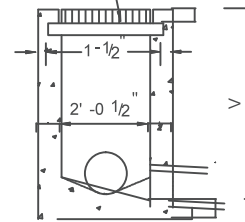

**SECTION A-A**

**NOTES:**

1. ALL CONCRETE SHALL BE CLASS 'A'.
2. CONNECTOR PIPES MAY BE PLACED IN ANY WALL AS PER PLAN.
3. FLOOR OF BASIN SHALL BE TROWELLED TO A HARD, SMOOTH SURFACE AND SHALL SLOPE FROM ALL DIRECTIONS TO OUTLET.
4. CONSTRUCTION DRAINS SHALL BE INSTALLED WHEN NOTED. (SEE DETAIL P1575)
5. CONNECTOR PIPE SHALL BE TRIMMED TO THE FINAL SHAPE AND LENGTH BEFORE CONCRETE IS POURED.
6. PLANS SHOULD SPECIFY ELEVATION AND INVERT ELEVATION.
7. THE TYPE 'N' CATCH BASIN MAY BE PREFABRICATED PROVIDING A SHOP DRAWING IS APPROVED BY THE ENGINEER PRIOR TO FABRICATION.
8. THE FRAME SHALL BE DET. P1564, TYPE 1 AND THE GRATE SHALL BE DET. P1565, TYPE 1.
9. EXPANSION JOINT (TYP)
10. INSTALL ONE CITY FURNISHED POLLUTION AWARENESS MARKER (PAM) AT EACH CATCH BASIN, AS DIRECTED BY THE ENGINEER.

**CATCH BASIN WALL THICKNESS**

T=6" IF V = 4' OR LESS  
T=8" IF V = 4' TO 8'  
(IF V EXCEEDS 8' SPECIAL DESIGN IS REQUIRED)  
V=4'-0" UNLESS OTHERWISE NOTED.

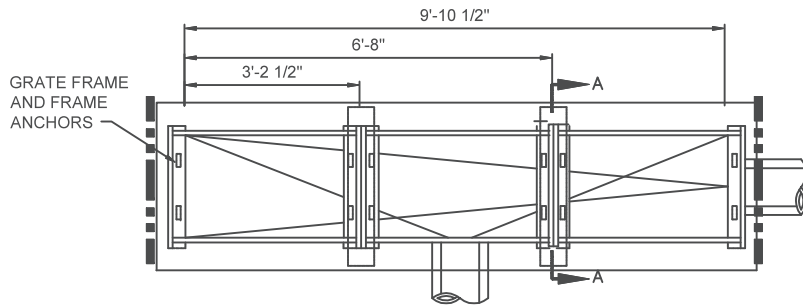

**TRIPLE CATCH BASIN PLAN**

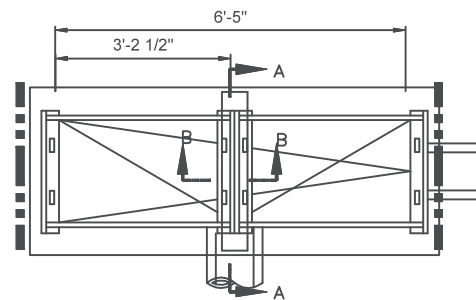

**DOUBLE CATCH BASIN PLAN**

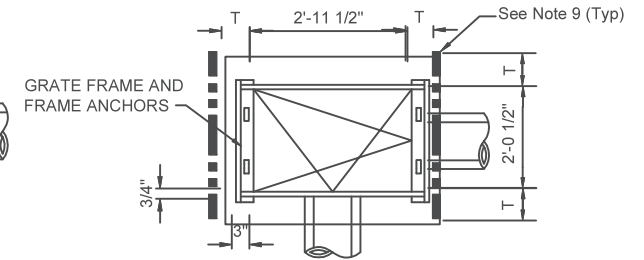

**SINGLE CATCH BASIN PLAN**

DETAIL NO.  
P1570



**City of Phoenix  
STANDARD DETAIL**

CATCH BASIN  
TYPE "N"

APPROVED

*[Signature]*  
CITY ENGINEER

12/10/2012  
DATE

DETAIL NO.  
P1570

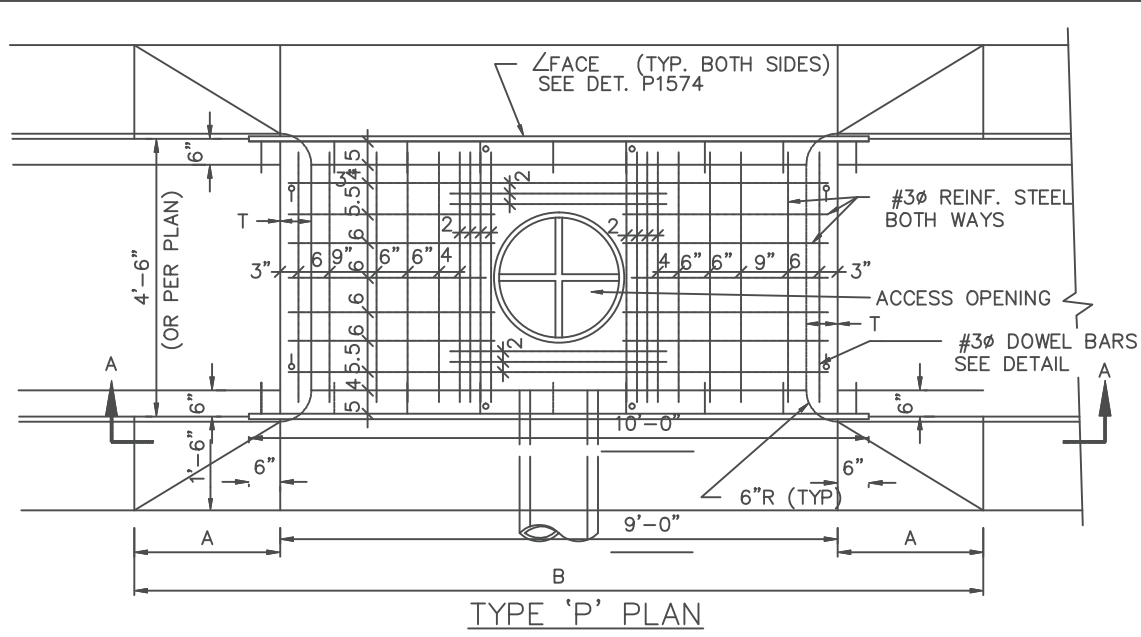

**NOTES:**

1. ALL CONCRETE SHALL BE CLASS 'A'.
2. ALL REINFORCING STEEL SHALL BE DEFORMED BARS AND SHALL CONFORM TO A.S.T.M. SPECIFICATION 615.
3. CONNECTOR PIPES MAY BE PLACED IN ANY WALL AS PER PLANS.
4. FLOOR OF BASIN SHALL BE TROWELLED TO A HARD, SMOOTH SURFACE AND SHALL SLOPE FROM ALL DIRECTIONS TO OUTLET.
5. CONSTRUCTION DRAINS SHALL BE INSTALLED IN ALL INLETS BUILT WITH PAVING PROJECTS. (SEE DET. P1575.)
6. ACCESS FRAME AND COVER PER DET. P1561.
7. INSTALL ONE CITY FURNISHED POLLUTION AWARENESS MARKER (PAM) AT EACH CATCH BASIN, AS DIRECTED BY THE ENGINEER.

CATCH BASIN WALL THICKNESS	
T=6"	IF V = 4' OR LESS
T=8"	IF V = 4' TO 8'
IF V EXCEEDS 8', SPECIAL DESIGN IS REQUIRED.	
V=4'-0" UNLESS UNLESS OTHERWISE SPECIFIED.	

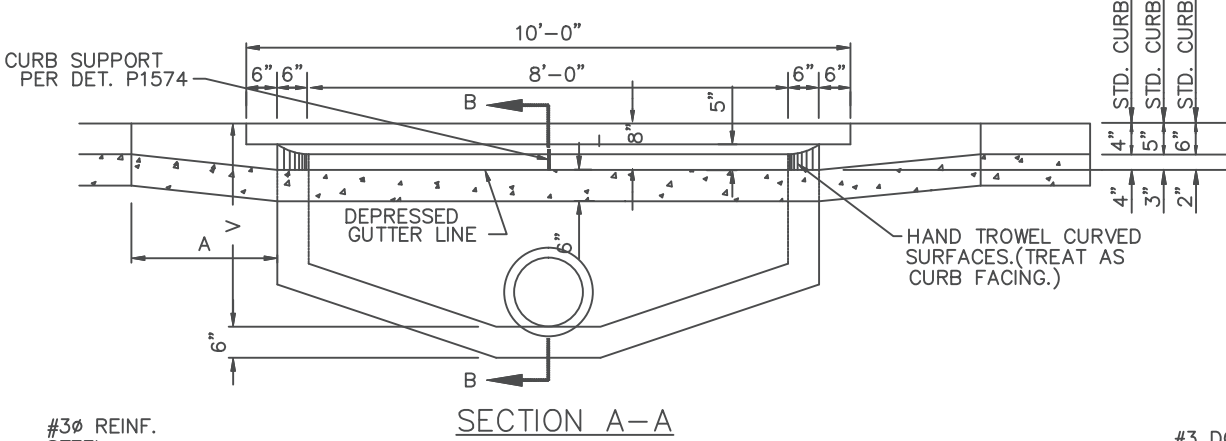

#3 DOWEL BAR SEE DETAIL. (NOT USED IF TOP IS PRECAST).

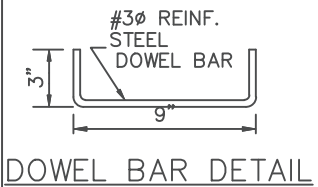
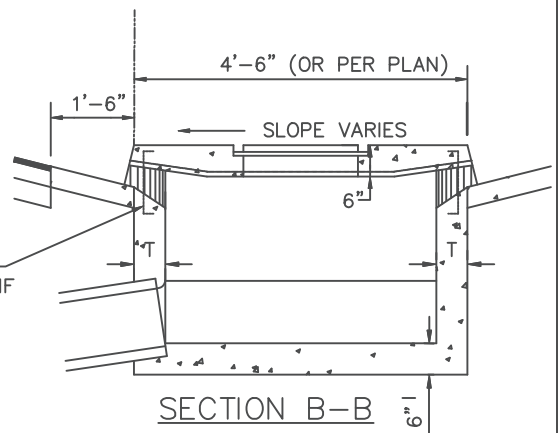

CURB	A	B
4"	3'-3"	15'-6"
5"	2'-6"	14'-0"
6"	1'-9"	12'-6"

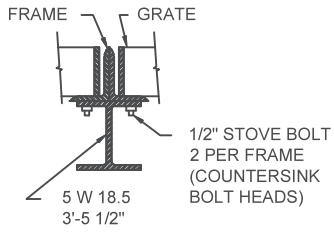

**SECTION B-B**

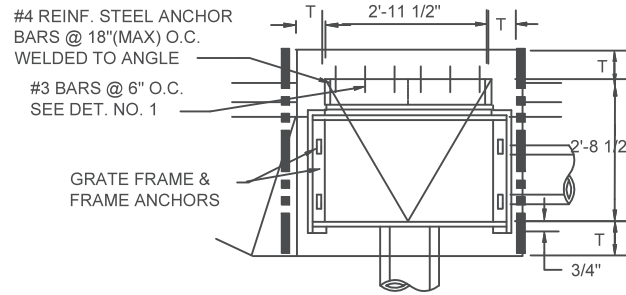

**SINGLE CATCH BASIN PLAN**

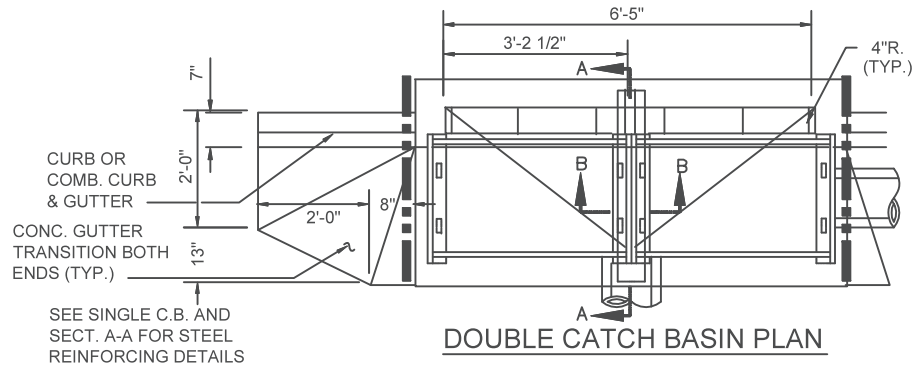

**DOUBLE CATCH BASIN PLAN**

#3 BARS @ 6" O.C., 1-1/2" CLEAR TO TOP OF NOSE SECTION & INSIDE OF WALL SEE DET. NO. 1

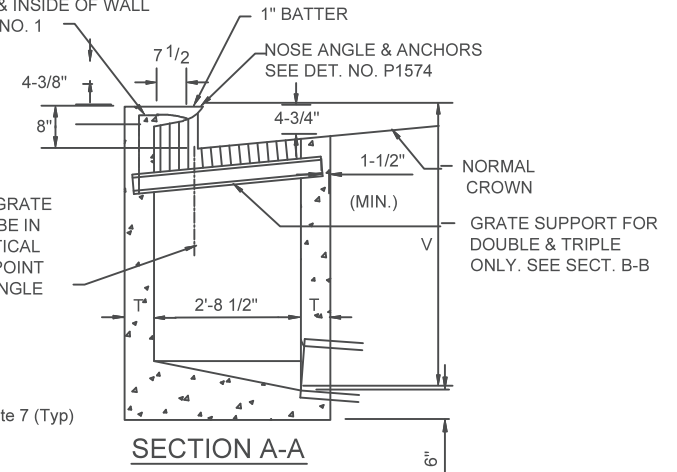

**SECTION A-A**

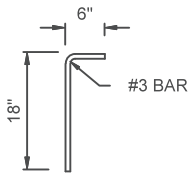

**DETAIL 1**

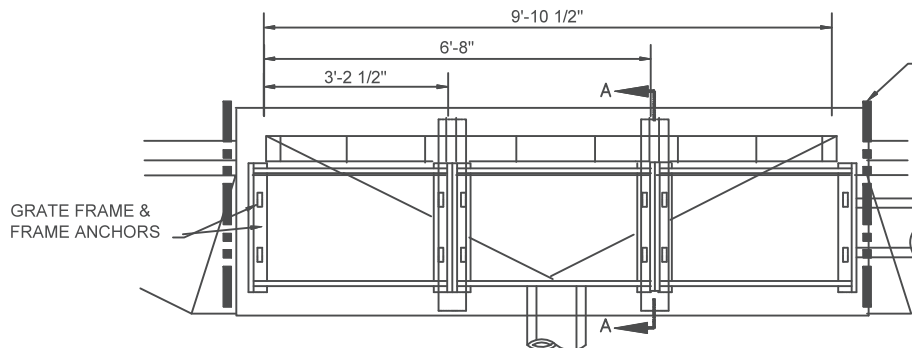

**TRIPLE CATCH BASIN PLAN**

**NOTES:**

1. ALL CONCRETE SHALL BE CLASS 'A'.
2. CONNECTOR PIPES MAY BE PLACED IN ANY WALL AS PER PLAN.
3. FLOOR OF BASIN SHALL BE TROWELLED TO A HARD, SMOOTH SURFACE AND SHALL SLOPE FROM ALL DIRECTIONS TO OUTLET.
4. CONSTRUCTION DRAINS SHALL BE INSTALLED WHEN NOTED. (SEE DETAIL P1575)
5. CONNECTOR PIPE SHALL BE TRIMMED TO THE FINAL SHAPE AND LENGTH BEFORE CONCRETE IS POURED.
6. THE FRAME SHALL BE DET. P1564, TYPE 1 AND THE GRATE SHALL BE DET. P1565, TYPE 1.
7. EXPANSION JOINT (TYP)
8. INSTALL ONE CITY FURNISHED POLLUTION AWARENESS MARKER (PAM) AT EACH CATCH BASIN, AS DIRECTED BY THE ENGINEER.

**CATCH BASIN WALL THICKNESS**

T=6" IF V = 4' OR LESS  
 T=8" IF V = 4' TO 8'  
 IF V EXCEEDS 8' SPECIAL DESIGN IS REQUIRED  
 V=4'-0' UNLESS OTHERWISE NOTED.

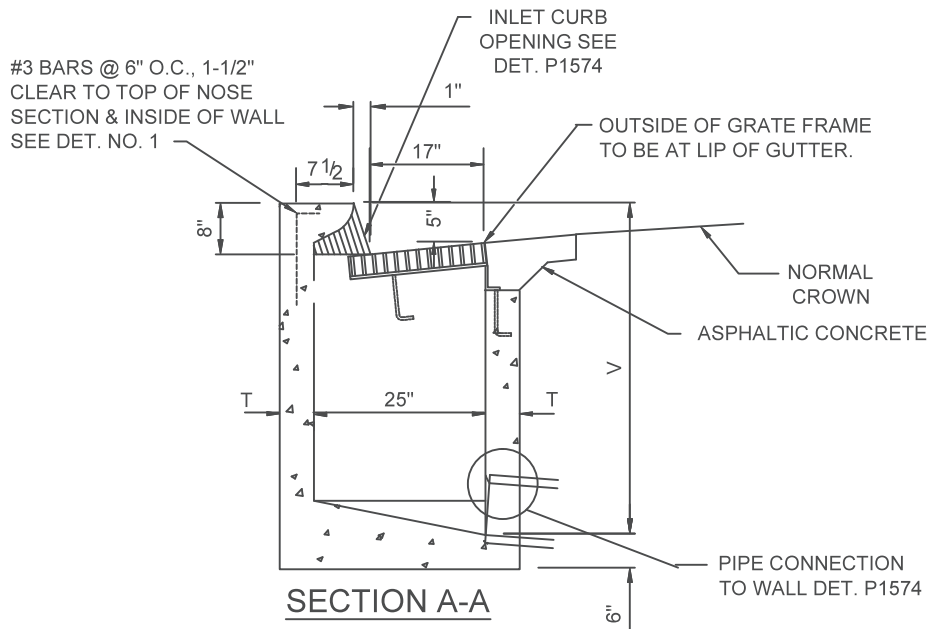

NOTES:

1. ALL CONCRETE SHALL BE CLASS 'A'.
2. CONNECTOR PIPES MAY BE PLACED IN ANY WALL AS PER PLAN.
3. FLOOR OF BASIN SHALL BE TROWELLED TO A HARD, SMOOTH SURFACE AND SHALL SLOP FROM ALL DIRECTIONS TO OUTLET.
4. THE CONSTRUCTION DRAINS SHALL BE INSTALLED IN ALL INLETS BUILT WITH PAVING PROJECTS (SEE DET. P1575).
5. CONNECTOR PIPE SHALL BE TRIMMED TO THE FINAL SHAPE AND LENGTH BEFORE CONCRETE IS POURED.
6. LOCATION OF THE TYPE 'R' CATCH BASIN SHALL BE RESTRICTED TO AREAS WHERE 6" VERTICAL CURB & GUTTER IS EXISTING.
7. ALL REINFORCING STEEL SHALL BE DEFORMED BARS AND SHALL CONFORM TO A.S.T.M. SPECIFICATION 615.
8. THE FRAME SHALL BE DET. P1564, TYPE 2 AND THE GRATE SHALL BE DET. P1565, TYPE 2.
9. EXPANSION JOINT (TYP)
10. INSTALL ONE CITY FURNISHED POLLUTION AWARENESS MARKER (PAM) AT EACH CATCH BASIN, AS DIRECTED BY THE ENGINEER.

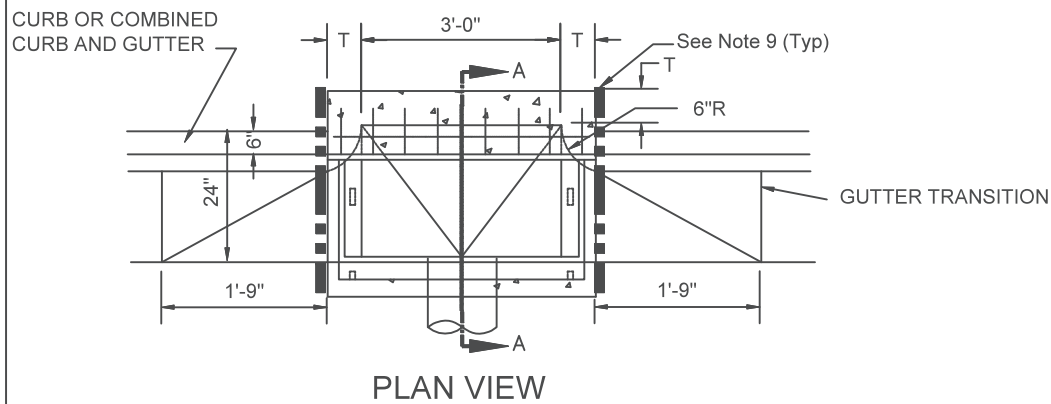

**CATCH BASIN WALL THICKNESS**

T=6" IF V = 4' OR LESS  
 T=8" IF V = 4' TO 8'  
 IF V EXCEEDS 8' SPECIAL DESIGN IS REQUIRED  
 V=4'-0" UNLESS OTHERWISE NOTED.

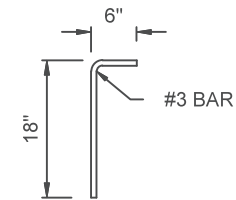

DETAIL 1

DETAIL NO.  
P1573



**City of Phoenix**  
STANDARD DETAIL

CATCH BASIN  
TYPE "R"

APPROVED

*[Signature]*  
CITY ENGINEER

12/10/2012  
DATE

DETAIL NO.  
P1573

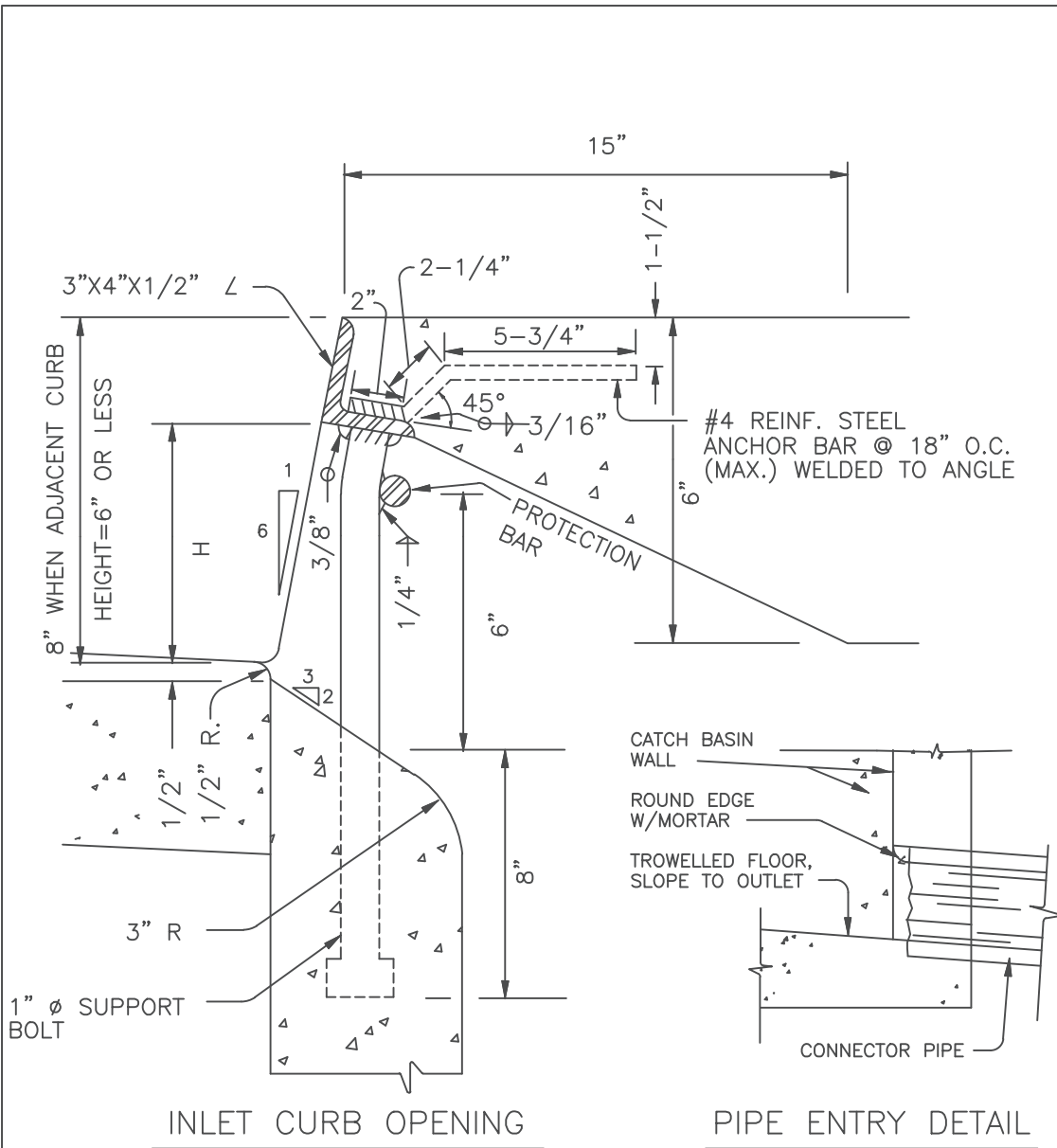

## NOTES

1. CURB OPENING HEIGHT 'H' SHALL BE 5" (MINIMUM) UNLESS OTHERWISE SPECIFIED.
2. WHEN CURB OPENING HEIGHT 'H' EXCEEDS 6", INSTALL 1"Ø STEEL PROTECTION BARS. THE PROTECTION BARS SHALL EXTEND THE FULL LENGTH OF THE CURB OPENINGS AND SHALL BE EMBEDDED 3"(MIN.) AT EACH END.
3. INSTALL ADDITIONAL BARS AT 3 1/2" CLEAR SPACING ABOVE FIRST BAR WHEN OPENING EXCEEDS 13".
4. WHEN CURB OPENING LENGTH EXCEEDS 6', INSTALL 1"Ø STEEL SUPPORT BOLTS, SPACED AT NO MORE THAN 5' O.C.
5. ALL EXPOSED METAL HARDWARE SHALL BE GIVEN ONE SHOP COAT OF NO.1 PAINT AND 2 FIELD COATS OF NO.10 PAINT AS PER SECTION 790.
6. ALL METAL UNITS SHALL BE FABRICATED FROM STRUCTURAL STEEL EXCEPT AS NOTED. STRUCTURAL STEEL SHALL BE IN ACCORDANCE WITH A.S.T.M. A-36.
7. WELDING SHALL BE IN ACCORDANCE WITH M.A.G. WELDING SPECIFICATIONS.
8. CONNECTOR PIPE SHALL BE TRIMMED TO THE FINAL SHAPE AND LENGTH BEFORE CONCRETE IS POURED.
9. WHEN CATCH BASIN IS LOCATED WITHIN A LANDSCAPE PARKWAY SECTION, SEE DETAIL P1569-2 FOR INLET MODIFICATIONS.

DETAIL NO.  
P1574



**City of Phoenix**  
**STANDARD DETAIL**

INLET CURB OPENING & PIPE ENTRY DETAIL

APPROVED

*Kenny Whelan*  
CITY ENGINEER

7/9/92  
DATE

DETAIL NO.  
P1574

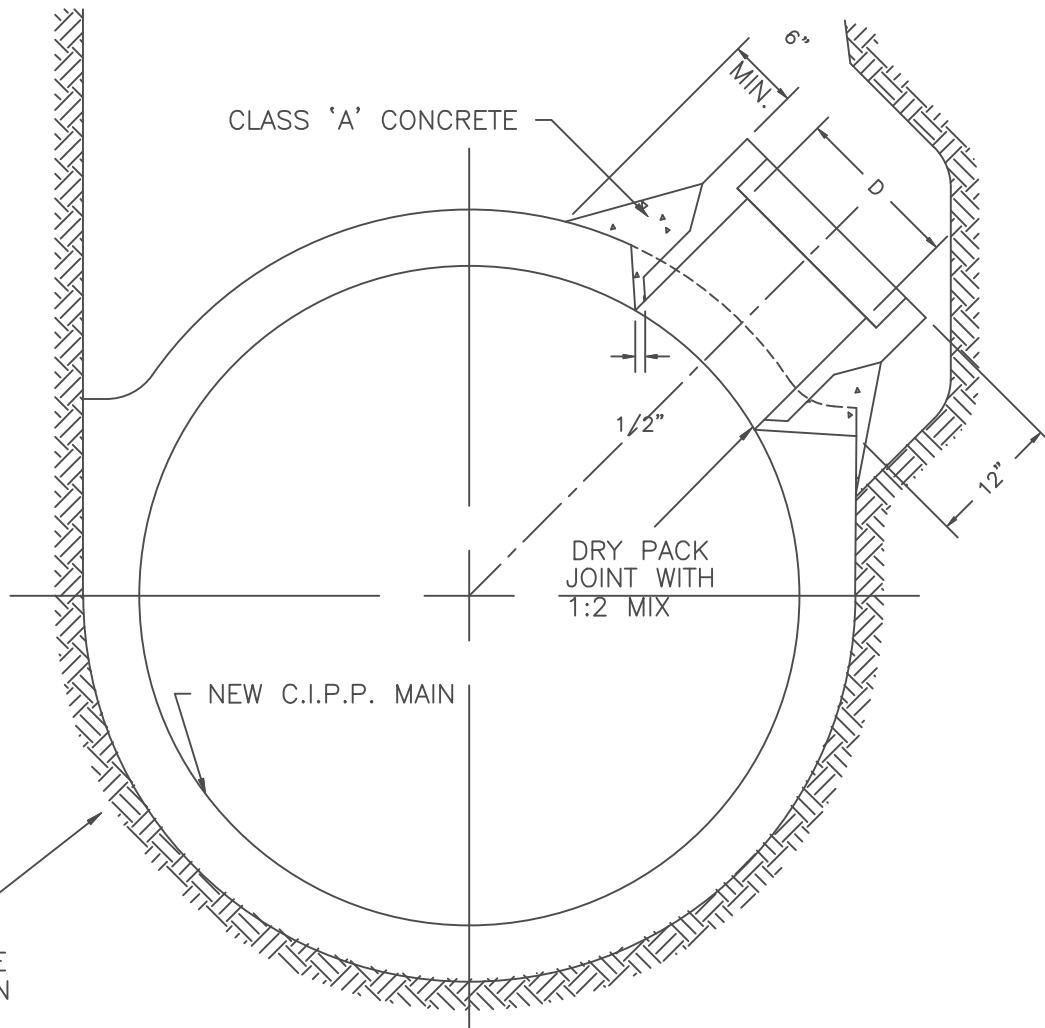

NOTES:

1. "D" SHALL BE 24" OR LESS.
2. PRECAST TEE SHALL BE INSTALLED WHERE THE MAINLINE PIPE IS SMALLER THAN THE MINIMUM OR THE CONNECTING PIPE IS LARGER THAN 24".
3. THE BELL END OF THE PRECAST CONCRETE PIPE SHALL BE INSTALLED AS SHOWN WHILE CONCRETE OF MAINLINE PIPE IS WET.
4. TRENCH WALL TO BE EXCAVATED AS NECESSARY PRIOR TO POURING MAINLINE PIPE TO ACCOMMODATE LATERAL STUB.
5. AXIS OF LATERAL STUB SHALL BE AS PER PLAN AND CROSS-SECTION.
6. THE LATERAL STUB SHALL SATISFY STRENGTH REQUIREMENTS AS SPECIFIED FOR THE LATERAL PIPE.
7. LATERALS FOR FUTURE CONNECTION SHALL BE MARKED. (SEE MAG DETAIL 427)

CONNECTING PIPE SIZE	MINIMUM SIZE MAIN
15"	24"
18"	36"
21"	42"
24"	48"

DETAIL NO.  
P1576



**City of Phoenix**  
**STANDARD DETAIL**

CAST-IN-PLACE PIPE  
LATERAL PIPE CONNECTION

APPROVED

*Allen D. Connell*  
FOR CITY ENGINEER

8/6/99  
DATE

DETAIL NO.  
P1576



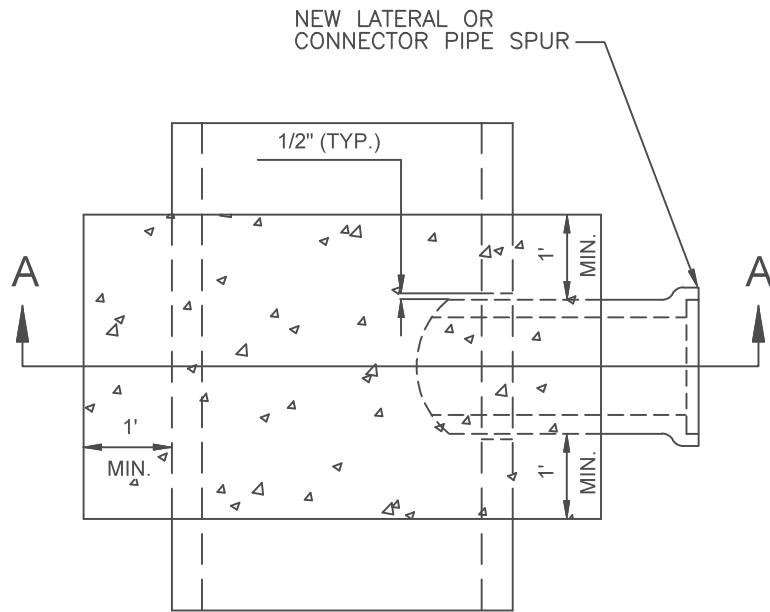

PLAN VIEW

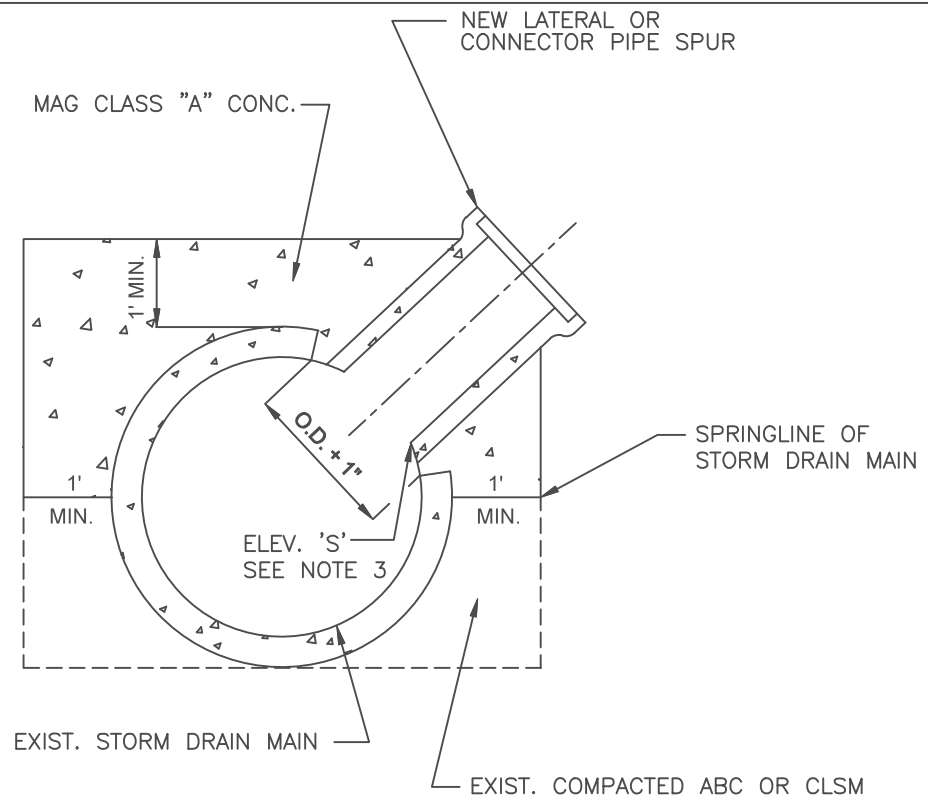

SECTION A-A

NOTES:

1. THIS DETAIL SHALL BE USED FOR CONNECTING NEW SMALL STORM DRAIN LATERALS OR CATCH BASIN CONNECTOR PIPES TO EXISTING STORM DRAIN MAINS.
2. THIS DETAIL SHALL ONLY BE USED WHEN OUTSIDE DIAMETER OF NEW LATERAL OR CONNECTOR PIPE SPUR IS LESS THAN OR EQUAL TO 1/2 THE INSIDE DIAMETER OF THE EXISTING STORM DRAIN MAIN.
3. THE CONNECTOR PIPE SPUR LINE SHALL BE CONSTRUCTED RADIAL TO THE MAIN, UNLESS OTHERWISE SHOWN BY ELEVATION 'S' AS SHOWN ON PLANS.
4. THE LENGTH OF THE SPUR STUB SHALL BE A MINIMUM OF 18" TO ALLOW FULL, CLEAN PIPE CONNECTION TO THE SPUR JOINT.
5. CONCRETE SHALL BE MAG CLASS "A".

DETAIL NO.  
P1577



**City of Phoenix**  
**STANDARD DETAIL**

SMALL STORM DRAIN LATERAL OR CATCH BASIN  
CONNECTOR PIPE CONNECTION TO EXISTING STORM DRAIN MAIN

APPROVED

*[Signature]*  
CITY ENGINEER

07/01/2015  
DATE

DETAIL NO.  
P1577

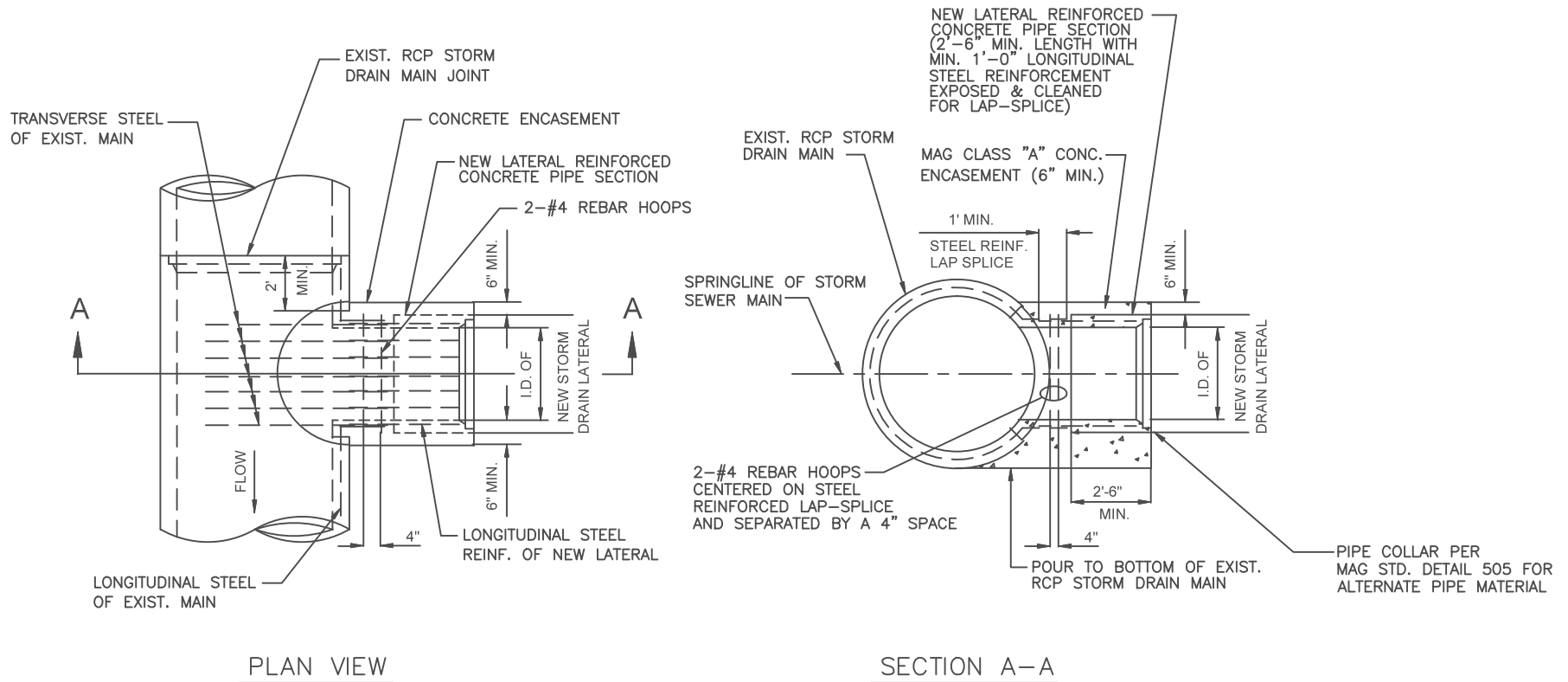

**NOTES:**

1. THIS DETAIL SHALL BE USED FOR CONNECTING NEW LARGE STORM DRAIN LATERALS OR CATCH BASIN CONNECTOR PIPES TO EXISTING RCP STORM DRAIN MAINS.
2. THIS DETAIL SHALL ONLY BE USED WHEN OUTSIDE DIAMETER OF NEW STORM DRAIN LATERAL OR CONNECTOR PIPE IS GREATER THAN 1/2, BUT LESS THAN THE FULL INSIDE DIAMETER OF THE EXISTING STORM DRAIN MAIN, AND NO OTHER TYPE CONNECTION (SUCH AS A MANHOLE OR SPECIAL JUNCTION STRUCTURE) IS FEASIBLE OR DESIRABLE.
3. THE EXISTING STORM DRAIN MAIN SHALL BE EXPOSED AT THE PROPOSED LOCATION OF NEW CONNECTION. IF NECESSARY, THE LOCATION MAY BE MOVED DOWN STREAM SUCH THAT THE OUTSIDE OF THE NEW OPENING WILL BE A MINIMUM OF 2' FROM THE NEAREST JOINT IN THE EXISTING PIPE MAIN.
4. A CIRCULAR OPENING IN THE EXISTING MAINLINE RCP PIPE SHALL BE CUT TO MATCH THE INSIDE DIAMETER OF THE NEW LATERAL, NORMAL TO THE PIPE SURFACE, WITHOUT DAMAGING STEEL. THE EXPOSED STEEL IN THE CIRCULAR OPENING OF THE EXISTING MAIN SHALL BE CUT TO PROVIDE RELATIVELY EQUAL-LENGTH REINFORCING STUBS AND BENT TO A HORIZONTAL POSITION IN PREPARATION FOR CONNECTION.
5. THE LONGITUDINAL STEEL ON THE END OF THE NEW STORM DRAIN LATERAL STUB SHALL BE PREPARED TO EXPOSE A MINIMUM 1'-0" OF CLEAN STEEL REINFORCEMENT FOR LAP-SPLICING AROUND THE PERIPHERY OF THE NEW STUB. THE EXPOSED STEEL OF THE EXISTING MAIN AND THE NEW STUB SHALL BE LAP-SPLICED A MINIMUM OF 1'-0" AND REINFORCE-TIED WITH 2-#4 REBAR HOOPS.
6. THE NEW STUB AND JOINT SHALL THEN BE ENCASED WITH A MINIMUM OF 6" OF MAG CLASS 'A' CONCRETE. THE ENCASUREMENT SHALL EXTEND THE ENTIRE LENGTH OF THE STUB (MIN. 2'-6"). THE SPLICE-JOINT AREA BETWEEN THE PIPES SHALL BE NEATLY FORMED INSIDE TO CREATE A CLEAN, FORMED JOINT.

DETAIL NO.  
P1578



**City of Phoenix**  
**STANDARD DETAIL**

LARGE STORM DRAIN LATERAL OR CATCH BASIN  
CONNECTOR PIPE TO EXISTING RCP STORM DRAIN MAIN

APPROVED

*[Signature]*  
CITY ENGINEER

07/01/2015  
DATE

DETAIL NO.  
P1578

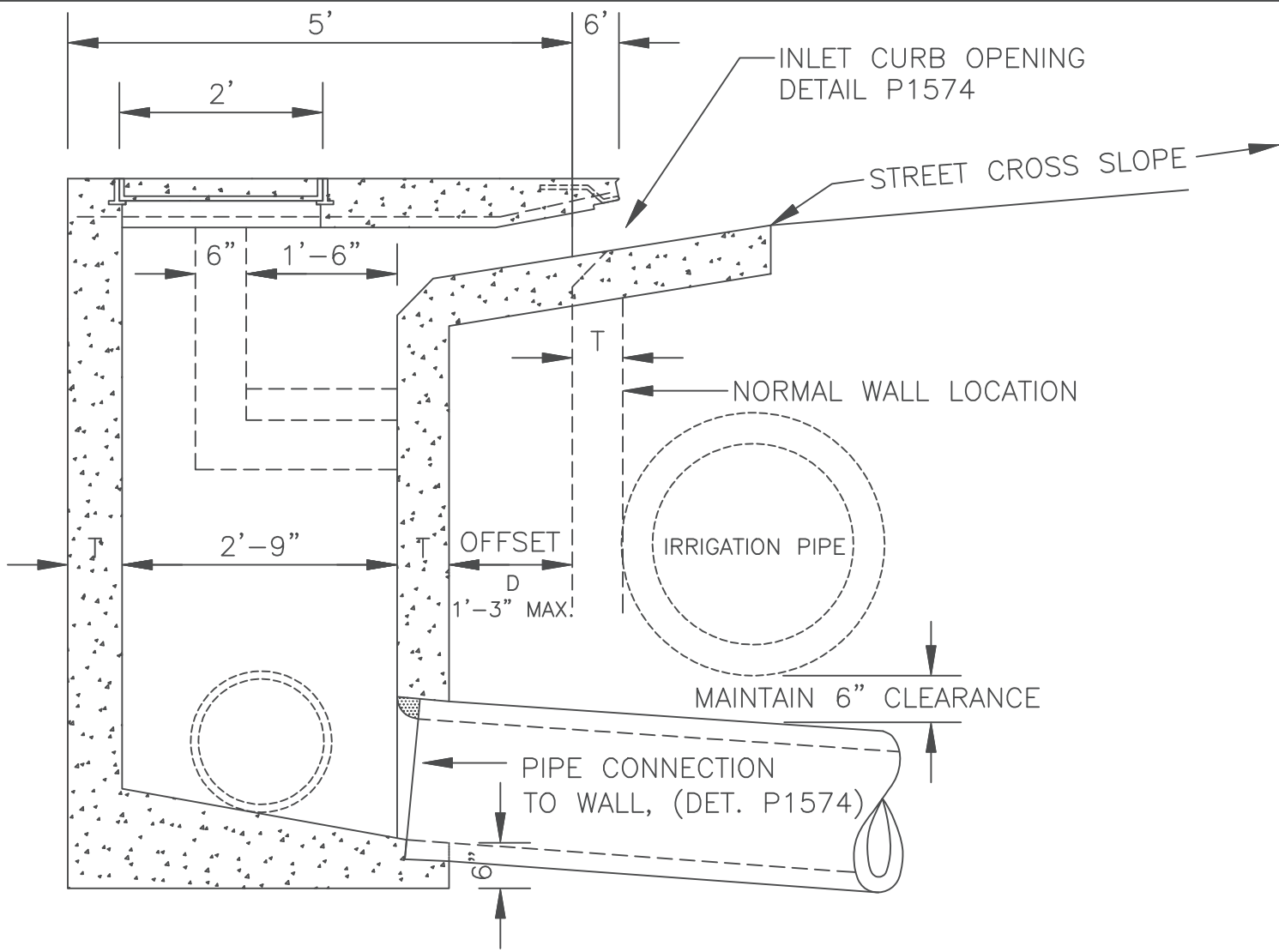

SECTION A-A

FOR ADDITIONAL INFORMATION & NOTES  
SEE CITY OF PHOENIX DETAIL P1569-1.

DETAIL NO. P1581	 <b>City of Phoenix</b> STANDARD DETAIL	CATCH BASIN - TYPE "M" MODIFIED (OFFSET OPENING)	APPROVED  CITY ENGINEER	DETAIL NO. P1581 7/3/00 DATE
---------------------	---	---	--	---------------------------------------

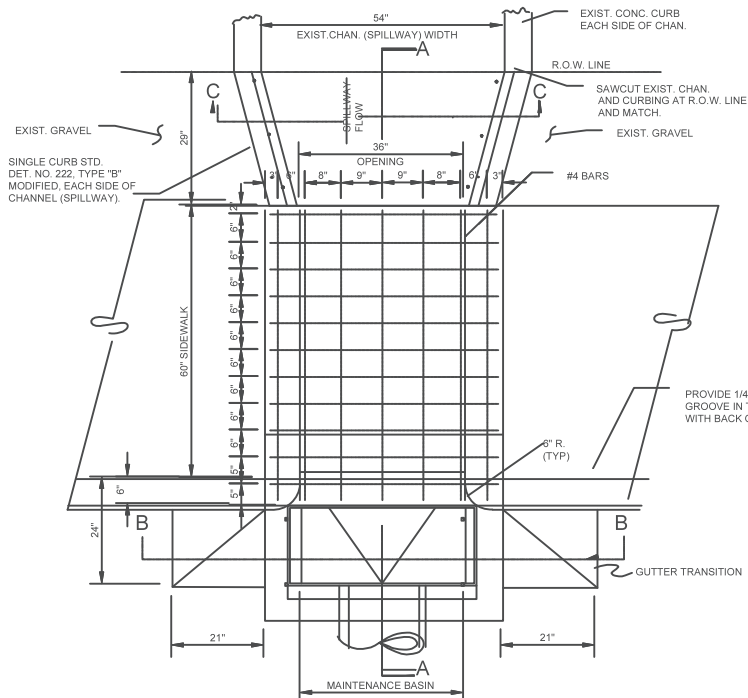

PLAN VIEW  
NO SCALE

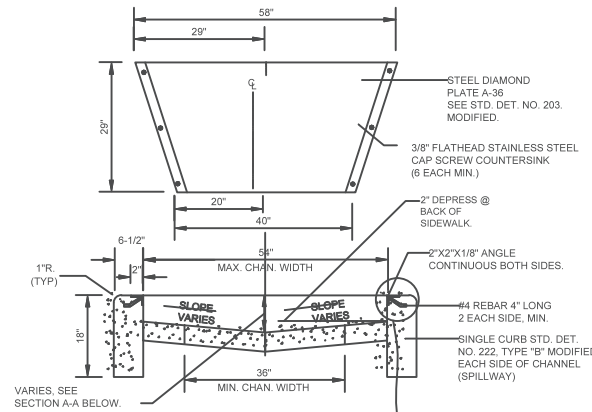
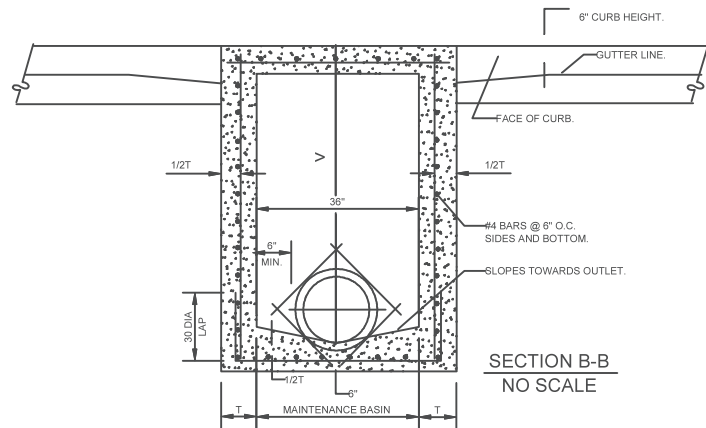

SECTION C-C  
NO SCALE

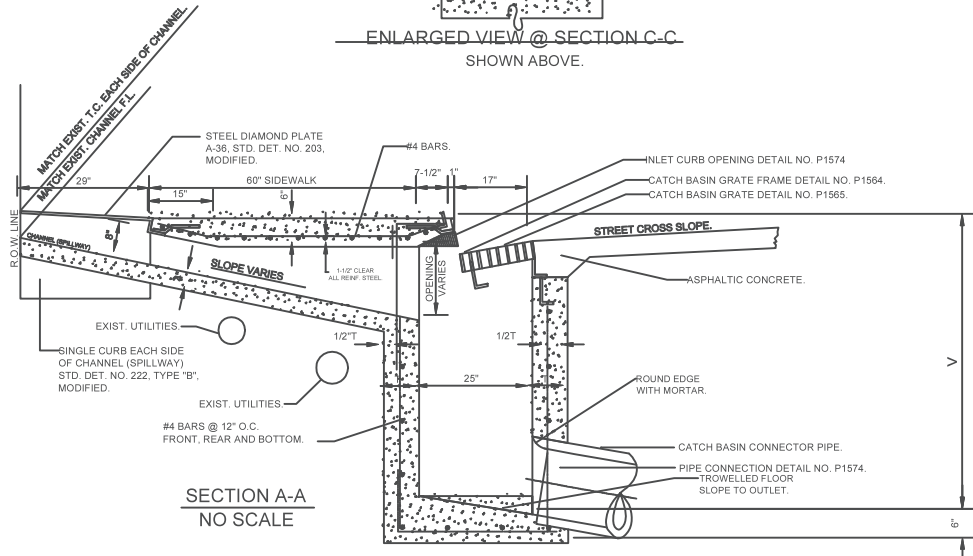
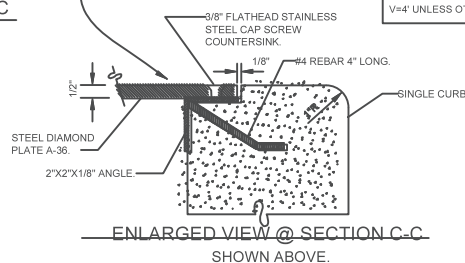

SECTION A-A  
NO SCALE

GENERAL NOTES:

1. ALL CONCRETE SHALL BE CLASS "A".
2. ALL REINFORCING STEEL SHALL BE DEFORMED BARS AND SHALL CONFORM TO A.S.T.M. SPECIFICATION NO. 615.
3. CONNECTOR PIPES MAY BE PLACED IN ANY WALL AS PER PLAN.
4. FLOOR OF BASIN SHALL BE TROWELLED TO A HARD SMOOTH SURFACE AND SHALL SLOPE FROM ALL DIRECTIONS TO OUTLET.
5. CONNECTOR PIPE SHALL BE TRIMMED TO THE FINAL SHAPE AND LENGTH BEFORE CONCRETE IS POURED.
6. THE FRAME SHALL BE DETAIL P1564, TYPE 2 AND THE GRATE SHALL BE DETAIL P1565, TYPE 2.
7. TYPE IS DESIGNATED AS FOLLOWS: COMBINATION TYPE "L-R" MODIFIED.
8. INSTALL ONE CITY FURNISHED POLLUTION AWARENESS MARKER (PAM) AT EACH CATCH BASIN, AS DIRECTED BY THE ENGINEER.

CATCH BASIN WALL THICKNESS & DEPTH	
T=6"	IF V 4' ≤ 6'
T=8"	IF V 4' > 6'
V=4'	UNLESS OTHERWISE SPECIFIED.

DETAIL NO.  
P1583



CATCH BASIN - TYPE "L-R" MODIFIED  
(WITH REAR INLET)

APPROVED  
*[Signature]*  
CITY ENGINEER  
12/10/2012  
DATE

DETAIL NO.  
P1583

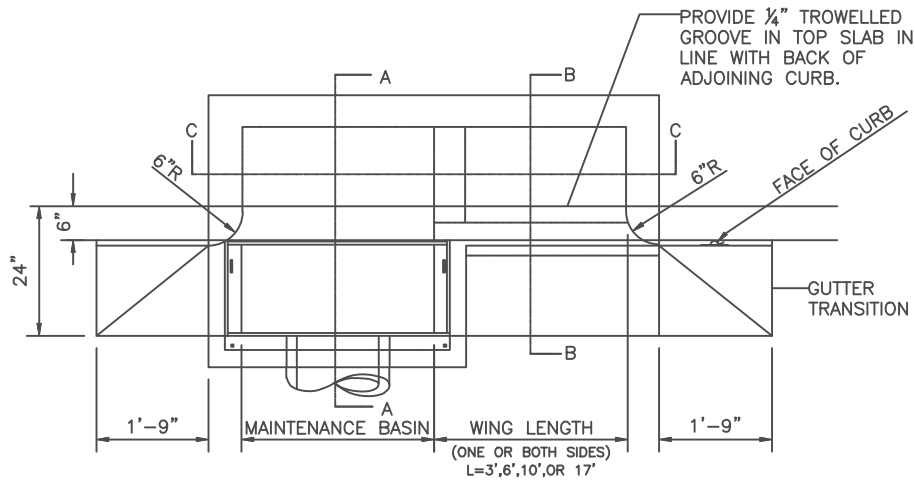

PLAN VIEW

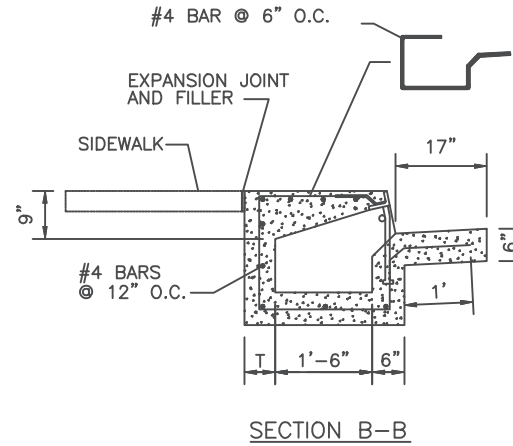

SECTION B-B

1. ALL CONCRETE SHALL BE CLASS "A".
2. ALL REINFORCING STEEL SHALL BE DEFORMED BARS AND SHALL CONFORM TO A.S.T.M. SPECIFICATION NO. 615.
3. CONNECTOR PIPES MAY BE PLACED IN ANY WALL AS PER PLAN.
4. FLOOR BASIN SHALL BE TROWELLED TO A HARD SMOOTH SURFACE AND SHALL SLOPE FROM ALL DIRECTIONS TO OUTLET.
5. CONSTRUCTION DRAINS SHALL BE INSTALLED IN ALL INLETS BUILT WITH PAVING PROJECTS (SEE DETAIL P1575).
6. CONNECTOR PIPE SHALL BE TRIMMED TO THE FINAL SHAPE AND LENGTH BEFORE CONCRETE IS POURED.
7. THE FRAME SHALL BE DETAIL P1564, TYPE 2 AND THE GRATE SHALL BE DETAIL P1565, TYPE 2.
8. TYPES ARE DESIGNATED AS FOLLOWS:  
 "R" MODIFIED -- NO WING;  
 "R-1" MODIFIED -- ONE WING;  
 "R-2" MODIFIED -- TWO WINGS.
9. INSTALL ONE CITY FURNISHED POLLUTION AWARENESS MARKER (PAM) AT EACH CATCH BASIN, AS DIRECTED BY THE ENGINEER.

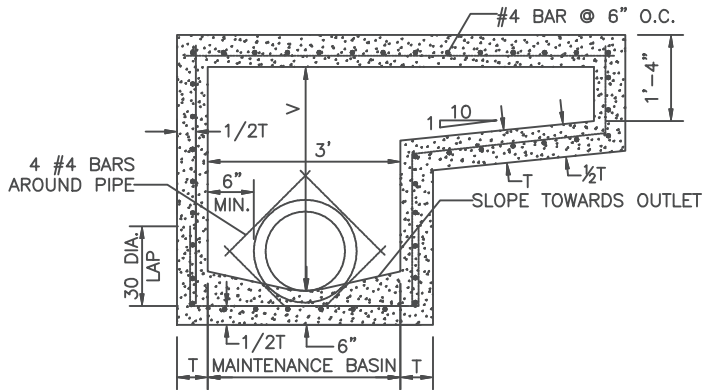

SECTION C-C

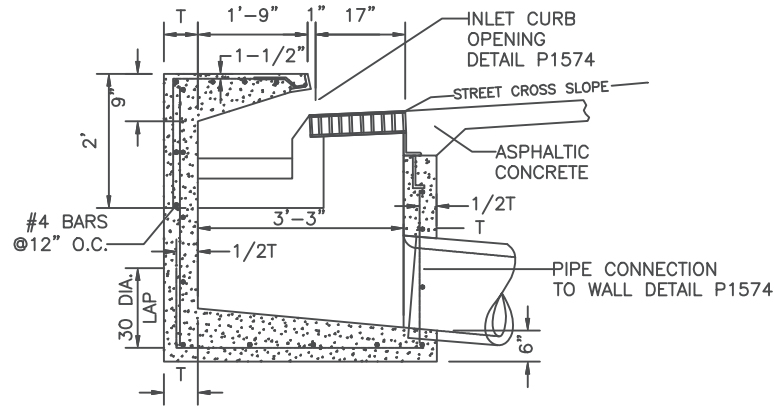

SECTION A-A

CATCH BASIN WALL THICKNESS & DEPTH
T=6" IF V=8' OR LESS.
T=8" IF V=8'-1" TO 16'.
V=4'-0" UNLESS OTHERWISE SPECIFIED.

DETAIL NO.  
P1584



**City of Phoenix**  
**STANDARD DETAIL**

CATCH BASIN - TYPE "R" MODIFIED  
(WITH WING AND OFFSET OPENING)

APPROVED

*[Signature]*  
CITY ENGINEER

12/10/2012  
DATE

DETAIL NO.  
P1584

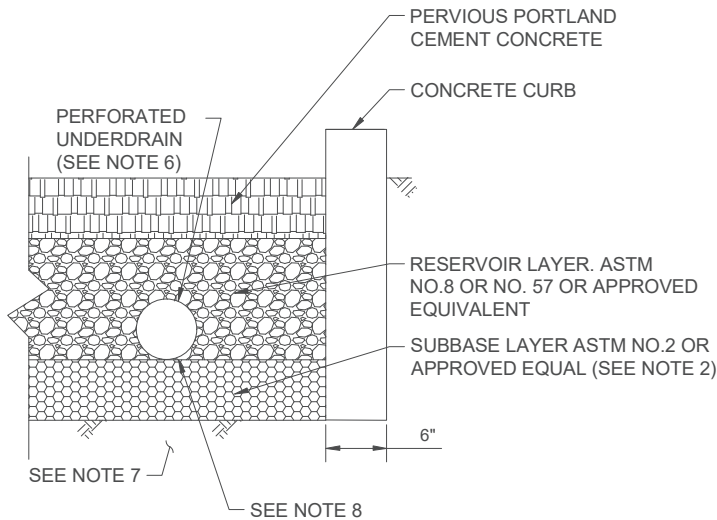

**NOTES:**

1. AGGREGATE LAYERS SHALL MEET PROPOSED SPECIAL PROVISION 303.
2. GEOSYNTHETIC TO BE USED TO PROTECT PIPES FROM CLOGGING. SEE MAG SPECIFICATION 796.
3. DEPTH OF RESERVOIR LAYER AS SHOWN ON DESIGN PLANS SHOULD BE SIZED TO DRAIN WITHIN 72 HOURS.
4. TOP OF PAVEMENT SHOULD BE DESIGNED TO ACHIEVE 1% MAXIMUM SLOPE IN ANY DIRECTION.
5. WHEN FILTER LAYER IS OMITTED, PROVIDE GEOSYNTHETIC CLASS-A MATERIAL BENEATH RESERVOIR LAYER.
6. UNDERDRAIN REQUIRED FOR LOW PERCOLATING SOILS (SEE SPECIFICATION 622).
7. UNCOMPACTED SUBGRADE FOR AREAS DESIGNED FOR INFILTRATION FEATURES ONLY.
8. GEOSYNTHETIC MATERIAL (SEE SPECIFICATION 796)
9. COMPACTION REQUIREMENTS IF ANY WILL BE DESIGNED BY GEOTECHNICAL ENGINEER.
10. SOLID PAVERS CAN BE USED (OPTIONAL).
11. MINIMUM COVER OVER THE UNDERDRAIN PER MANUFACTURER RECOMMENDATION.

**PERVIOUS CONCRETE PAVEMENT**

MINIMUM PAVEMENT THICKNESS		
PAVEMENT ITEM	CLASS A	CLASS B
PERVIOUS PORTLAND CEMENT CONCRETE	6"	8"
RESERVOIR LAYER	6", SEE NOTE 3	12", SEE NOTE 3
SUBBASE LAYER	4"	4"

**\* THIS DETAIL IS FOR ONSITE APPLICATION ONLY AND NOT APPROVED FOR USE WITHIN THE PUBLIC RIGHT OF WAY**

**PERVIOUS CONCRETE**

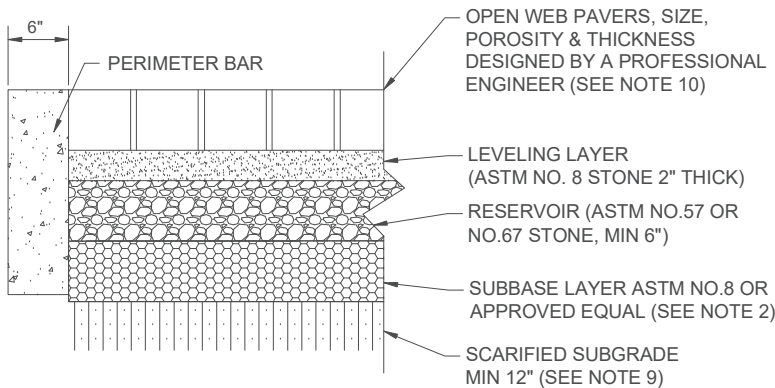

**PERVIOUS CONCRETE PAVERS**

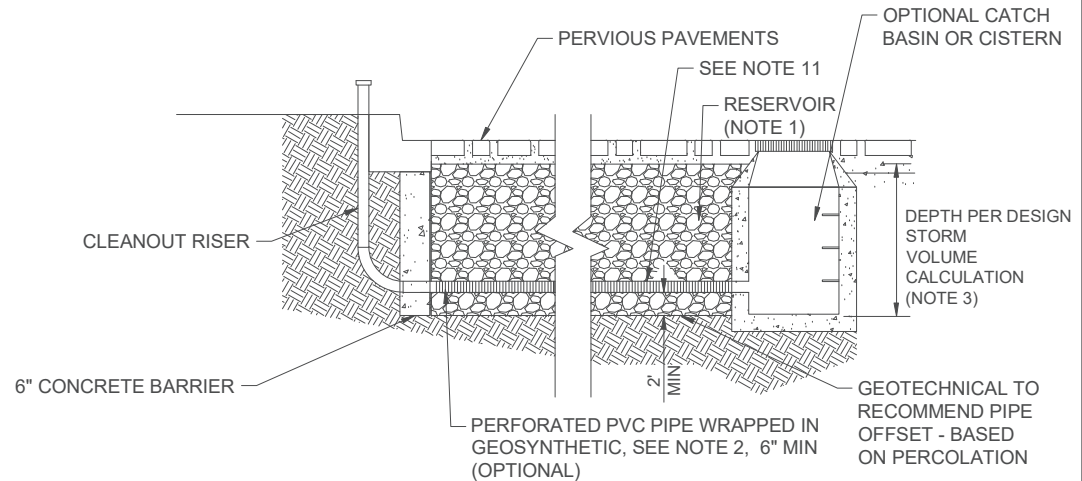

**PERMEABLE PAVEMENT WITH UNDERGROUND RESERVOIR AND UNDERDRAIN (OPTIONAL)**

DETAIL NO.  
LID-01

STANDARD DETAIL  
ENGLISH

PERMEABLE PAVEMENT

REVISED  
01-29-2019

DETAIL NO.  
LID-01

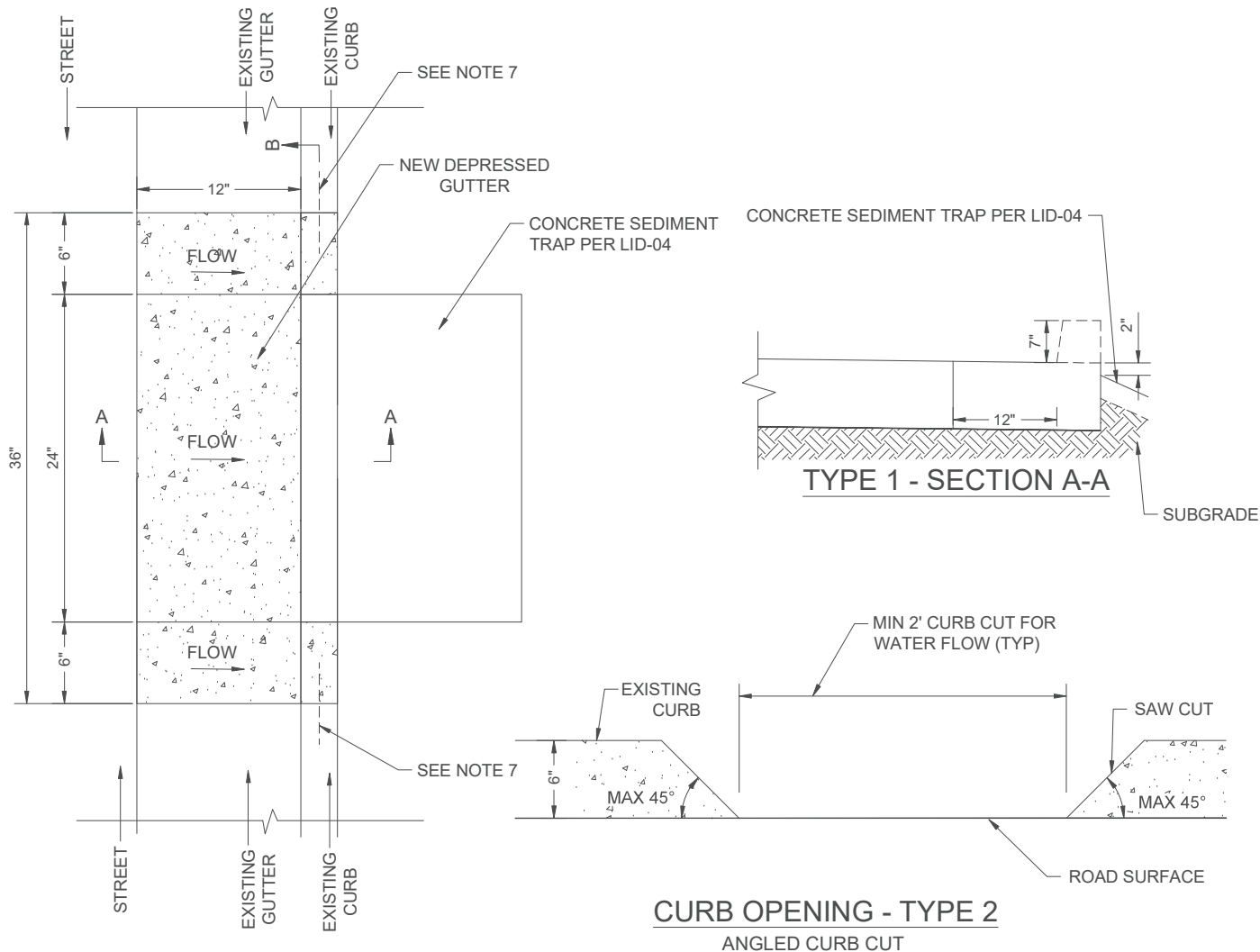

**CURB OPENING - TYPE 1**  
RETROFIT OPENING WITH VERTICAL CUT

**CURB OPENING - TYPE 2**  
ANGLED CURB CUT

**NOTES:**

1. HEADED CONCRETE ANCHORS SHALL MEET THE REQUIREMENTS OF ASTM A-108.
2. END PLATES SHALL MEET THE REQUIREMENTS OF ASTM A-36.
3. ENTIRE ASSEMBLY SHALL BE HOT DIP GALVANIZED IN ACCORDANCE WITH ASTM A-123.
4. DESIGN VERTICAL WHEEL LOAD IS 8.5 KIPS.
5. SEE SPECIFICATION 341 FOR MATERIAL AND CONSTRUCTION INFORMATION.
6. REFER TO AASHTO ROADWAY DESIGN GUIDE FOR CLEAR ZONE REQUIREMENTS FOR SPEED DESIGNS.
7. DRILL & EPOXY #4x6" REBAR
8. DETAIL SHALL BE USED IN COMBINATION WITH MAG 206 FOR ATTACHED SIDEWALKS.

**NOTES:**

1. DETAIL IS PROHIBITED FOR USE ALONG ARTERIAL CLASSIFIED ROADWAYS.
2. UTILIZATION WITHIN THE PUBLIC RIGHT OF WAY REQUIRES A PRIVATE MAINTENANCE AGREEMENT WITH THE CITY OF PHOENIX.

**NOTES:**

1. DO NOT CUT DEEPER THAN ROAD SURFACE ELEVATION.
2. ALL CURB OPENINGS SHALL BE MADE BY SAW CUT METHOD.
3. GRIND EXPOSED METAL AND SEAL TO PROTECT FROM CORROSION.

DETAIL NO.  
LID-02

STANDARD DETAIL  
ENGLISH

CURB OPENINGS

REVISED  
01-29-2019

DETAIL NO.  
LID-02

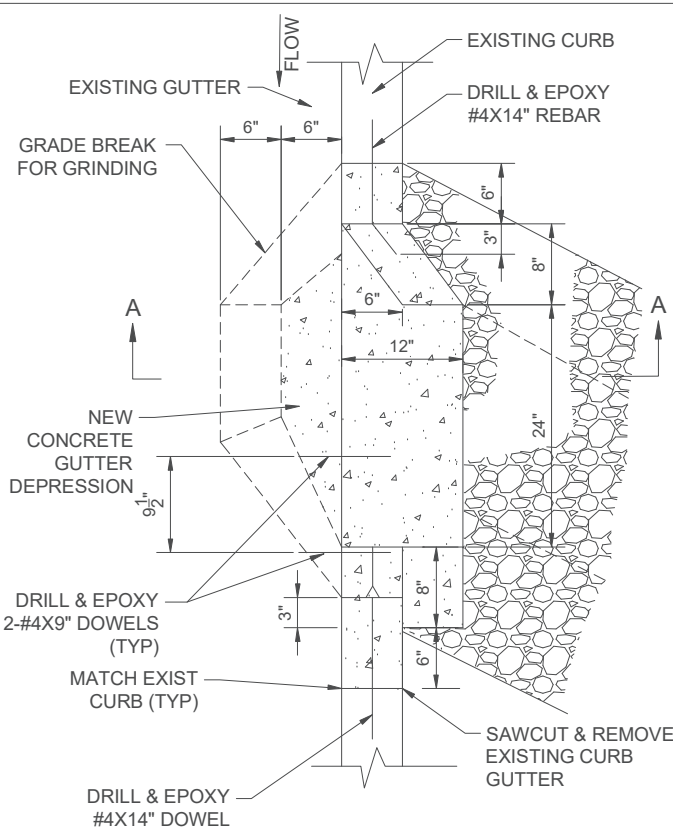

**TYPE 3 - PLAN VIEW**

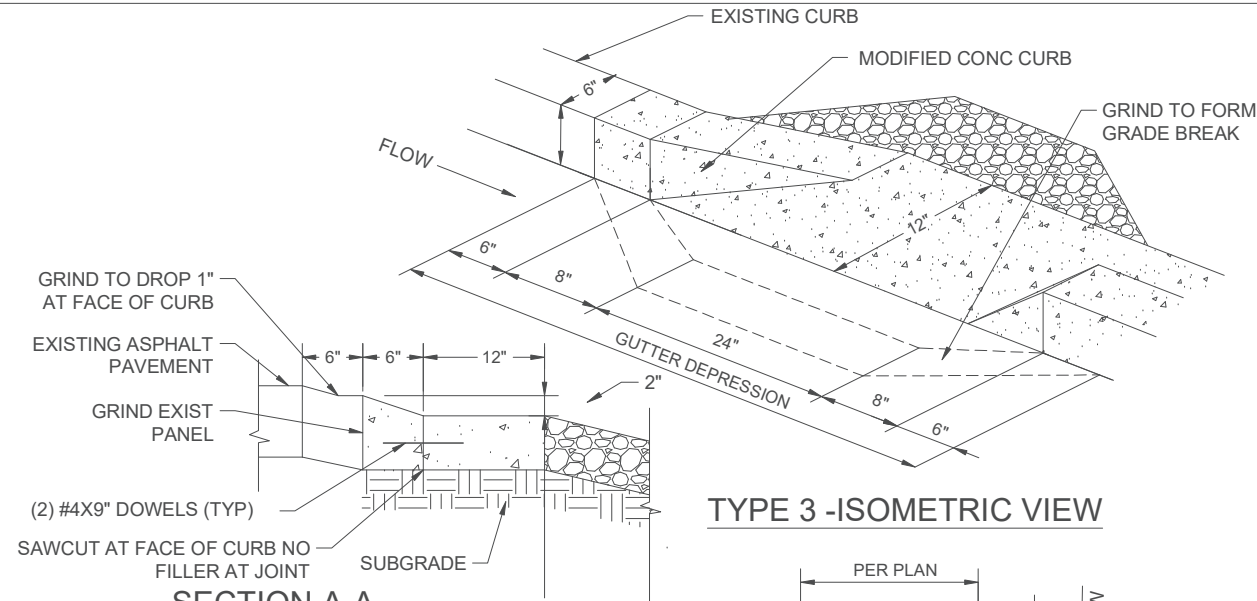

**TYPE 3 - ISOMETRIC VIEW**

**SECTION A-A  
CURB OPENING - TYPE 3  
CONCENTRATED FLOW INLET**

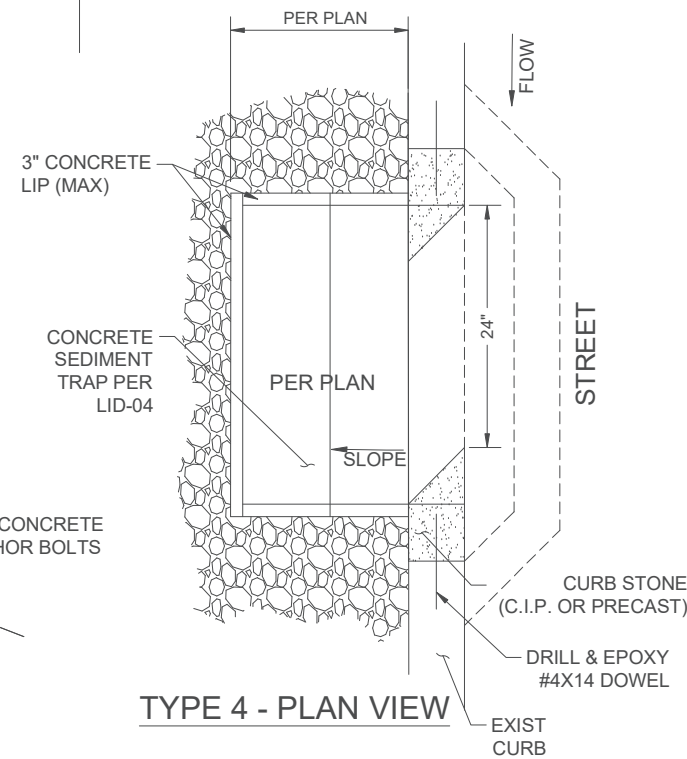

**TYPE 4 - PLAN VIEW**

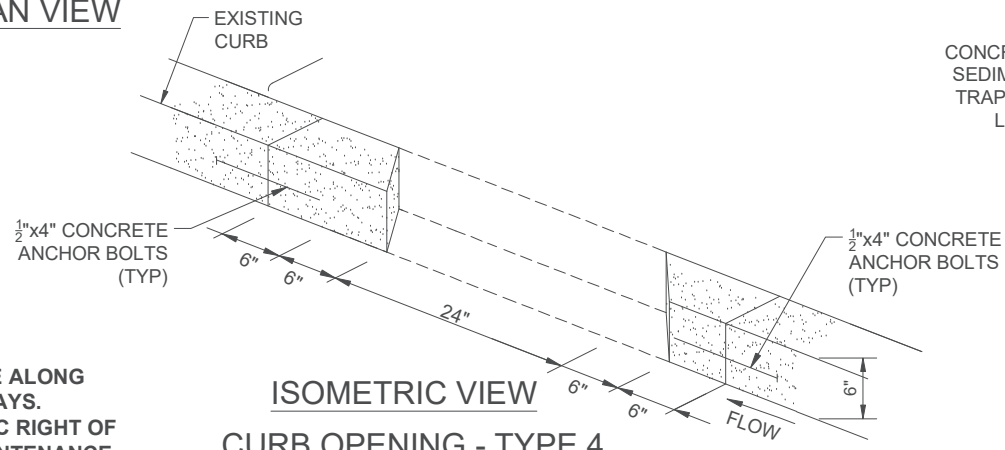

**ISOMETRIC VIEW  
CURB OPENING - TYPE 4  
CONCENTRATED FLOW INLET**

**NOTES:**

1. DETAIL IS PROHIBITED FOR USE ALONG ARTERIAL CLASSIFIED ROADWAYS.
2. UTILIZATION WITHIN THE PUBLIC RIGHT OF WAY REQUIRES A PRIVATE MAINTENANCE AGREEMENT WITH THE CITY OF PHOENIX.

DETAIL NO. LID-03	STANDARD DETAIL ENGLISH	CURB OPENINGS	REVISED 01-29-2019	DETAIL NO. LID-03
----------------------	----------------------------	---------------	-----------------------	----------------------



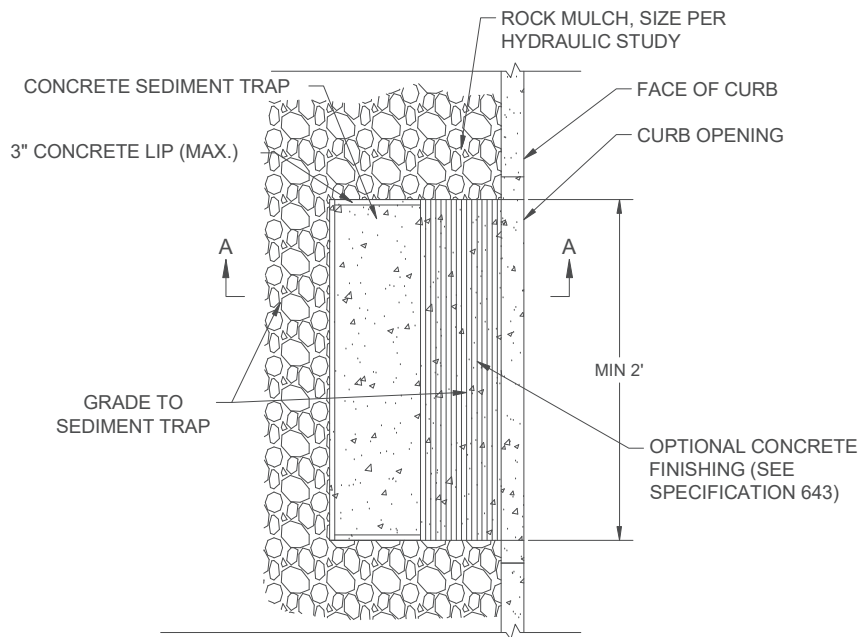

**SEDIMENT TRAP PLAN VIEW**

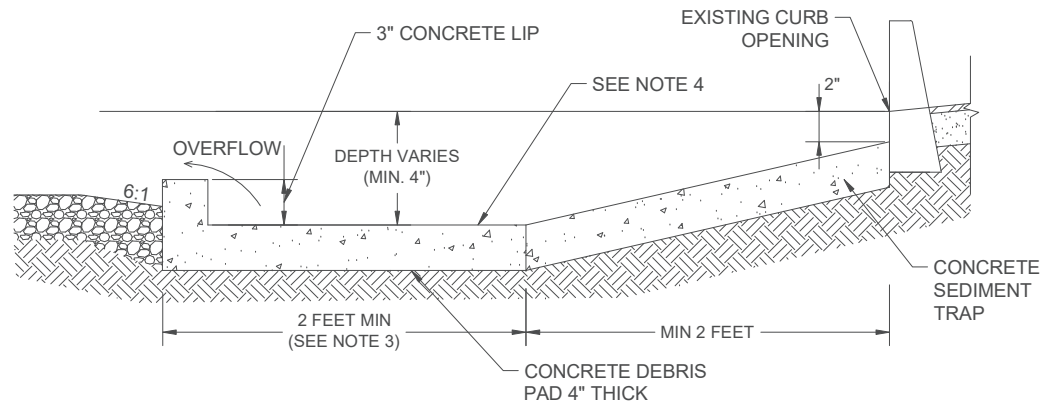

**NOTES:**

**SECTION A-A**

1. DIMENSIONS OF SEDIMENT TRAP SHOULD BE ADJUSTED BASED ON CONTRIBUTING WATERSHED SIZE AND SEDIMENT LOAD.
2. SEDIMENT TRAP CAN BE PRECAST OR CAST IN PLACE CONCRETE.
3. DEBRIS PAD SHOULD BE DESIGNED TO CONTAIN HYDRAULIC JUMP (IF POSSIBLE).
4. EXPANSION/CONTRACTION JOINT
5. RIPRAP SIZE BASED ON DESIGN REPORT.

**NOTES:**

1. **DETAIL IS PROHIBITED FOR USE ALONG ARTERIAL CLASSIFIED ROADWAYS.**
2. **UTILIZATION WITHIN THE PUBLIC RIGHT OF WAY REQUIRES A PRIVATE MAINTENANCE AGREEMENT WITH THE CITY OF PHOENIX.**

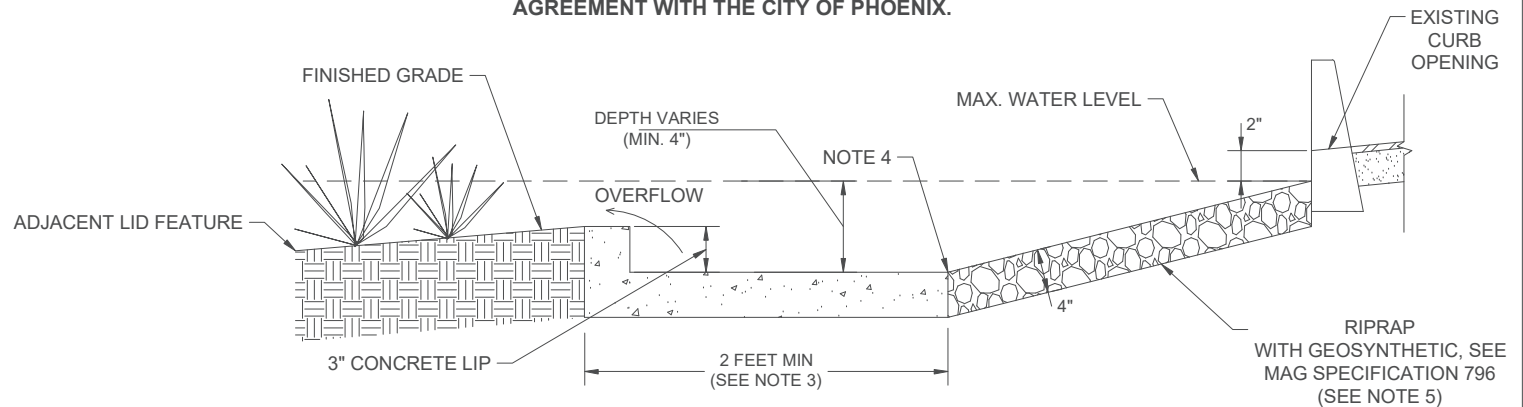

**SEDIMENT TRAP WITH RIPRAP SPILLWAY**

DETAIL NO. LID-04	STANDARD DETAIL ENGLISH	SEDIMENT TRAPS	REVISED 01-29-2019	DETAIL NO. LID-04
----------------------	----------------------------	----------------	-----------------------	----------------------

**GENERAL NOTES (BASIN):**

1. SURFACE WATER MUST DRAIN WITHIN 36 HOURS.
2. INFILTRATION AREA DEPTH AND WIDTH DETERMINED BY PERCOLATING WITHIN 72 HOURS. WIDTH MUST EXCEED DEPTH.
3. DEDICATED OUTFLOW MAY BE REQUIRED FOR THIS FEATURE.
4. FOR OPTIONAL PERFORATED UNDERDRAIN (SEE SPECIFICATION 622)
5. REFER TO AASHTO ROADWAY DESIGN BOOK FOR CLEAR ZONE REQUIREMENTS.
6. NO PLANTINGS IN THE CONCENTRATED FLOW INLET.
7. OPTIONAL SEDIMENT TRAP AT CONCENTRATED FLOW INLET.

**NOTES:**

1. DETAIL IS PROHIBITED FOR USE ALONG ARTERIAL CLASSIFIED ROADWAYS.
2. UTILIZATION WITHIN THE PUBLIC RIGHT OF WAY REQUIRES A PRIVATE MAINTENANCE AGREEMENT WITH THE CITY OF PHOENIX.

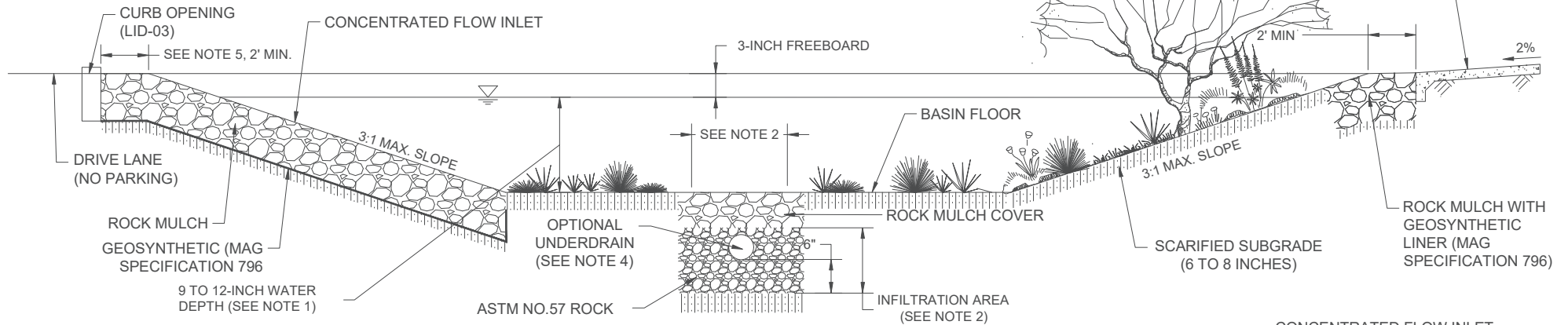

**STORMWATER HARVESTING BASIN SECTION WITH CUT THROUGH CONCENTRATED FLOW INLET**

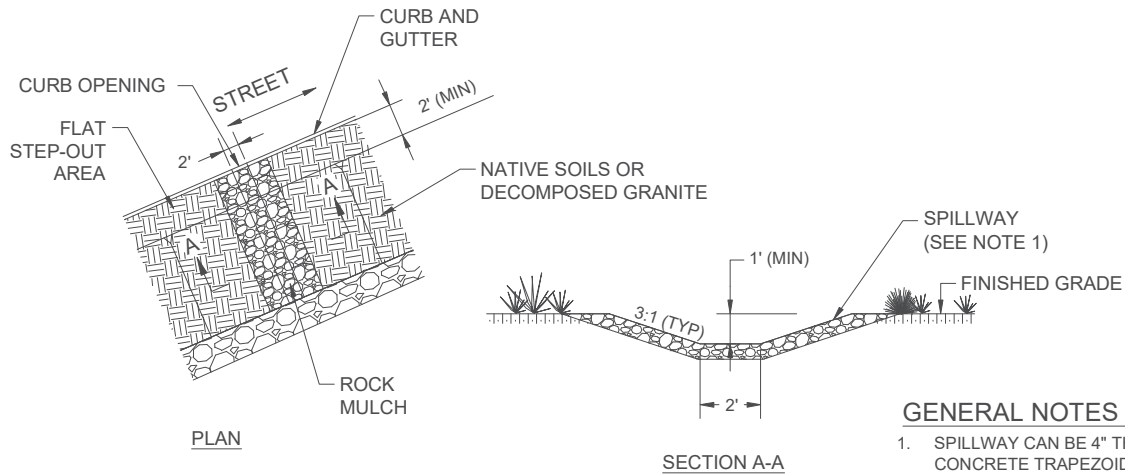

**GENERAL NOTES (INLET):**

1. SPILLWAY CAN BE 4" THICK CONCRETE TRAPEZOID SCUPPER 6" DEEP OR ROCK SPILLWAY BASED ON DESIGN.

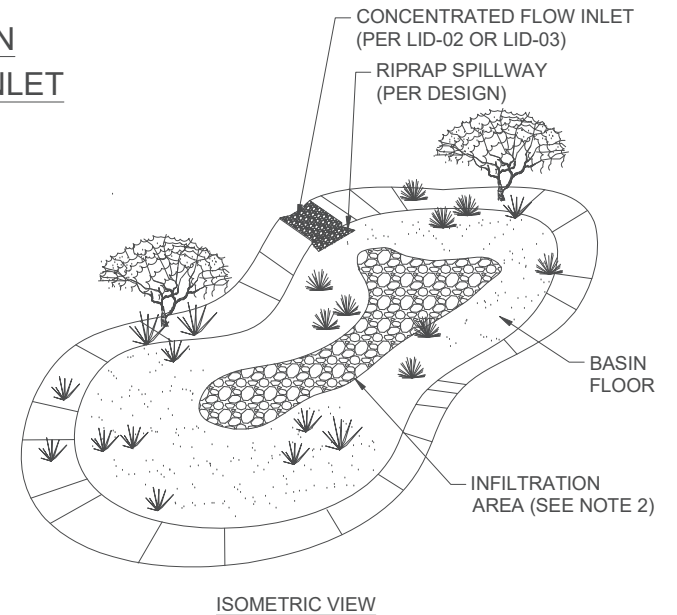

**RIPRAP SPILLWAY (PLAN & SECTION)**

DETAIL NO. LID-05	STANDARD DETAIL ENGLISH	STORMWATER HARVESTING BASINS	REVISED 01-29-2019	DETAIL NO. LID-05
----------------------	----------------------------	------------------------------	-----------------------	----------------------

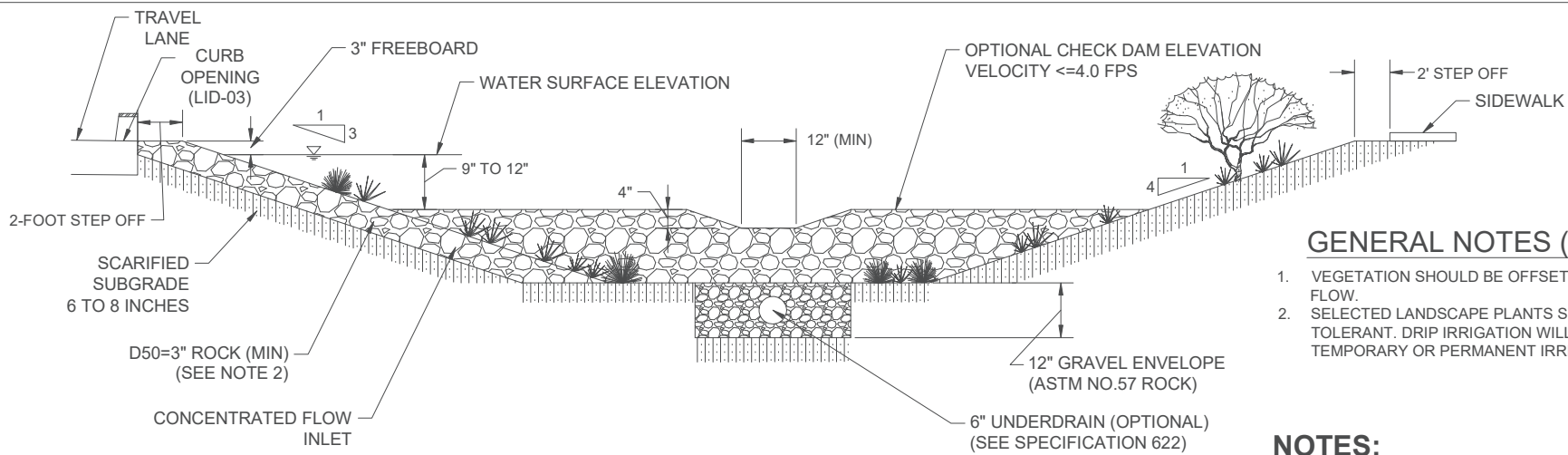

**GENERAL NOTES (BIOSWALE):**

1. VEGETATION SHOULD BE OFFSET FROM CONCENTRATED FLOW.
2. SELECTED LANDSCAPE PLANTS SHOULD BE DROUGHT TOLERANT. DRIP IRRIGATION WILL BE PROVIDED BY A TEMPORARY OR PERMANENT IRRIGATION SYSTEM.

**NOTES:**

1. DETAIL IS PROHIBITED FOR USE ALONG ARTERIAL CLASSIFIED ROADWAYS.
2. UTILIZATION WITHIN THE PUBLIC RIGHT OF WAY REQUIRES A PRIVATE MAINTENANCE AGREEMENT WITH THE CITY OF PHOENIX.

**BIOSWALE SECTION**

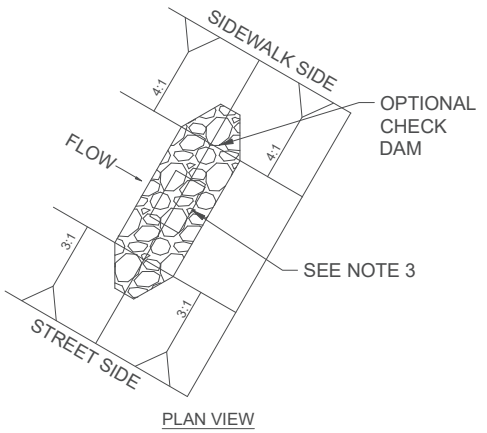
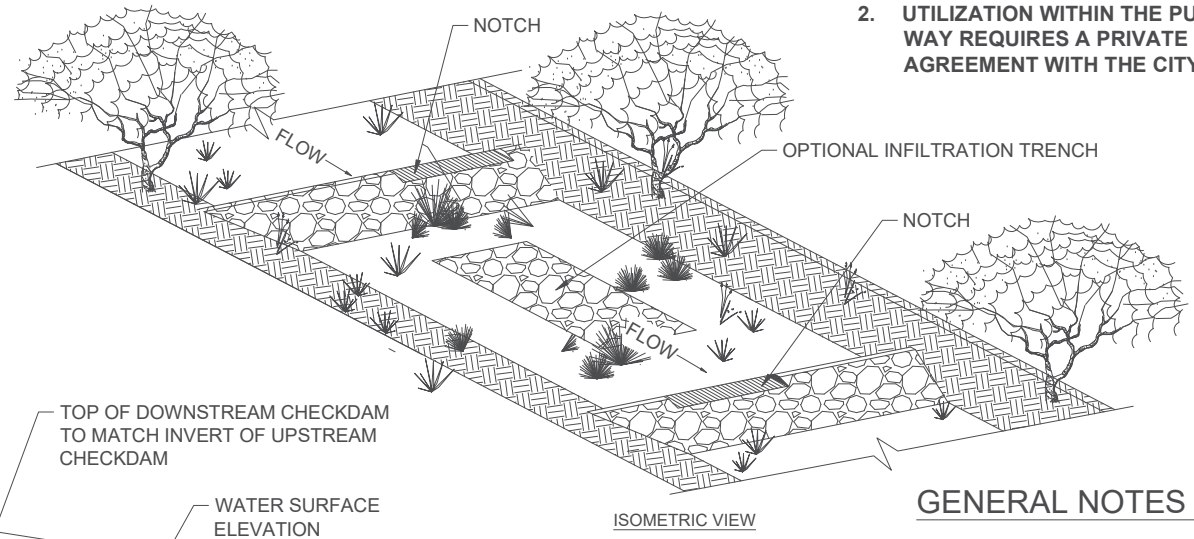

PLAN VIEW

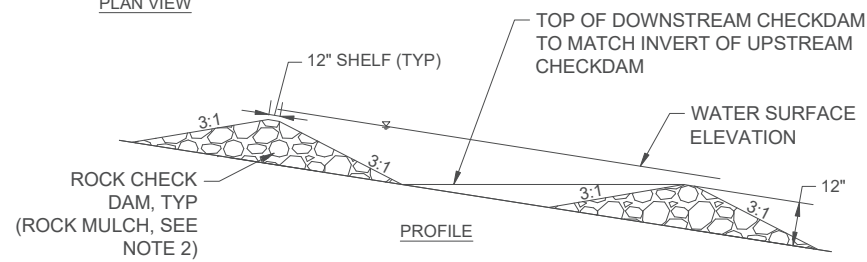

**OPTIONAL ROCK CHECK DAM**

**GENERAL NOTES (CHECK DAM):**

1. OPTIONAL CHECK DAM IS MEANT TO DISPERSE DURING HIGHER FLOWS, SEE SECTION 640.3.3 OF SPECIFICATIONS.
2. D50 SIZE DETERMINED BY THE DESIGN REPORT.
3. NOTCHES SHALL BE OFFSET FROM ONE ANOTHER.
4. DEDICATED OUTFLOW REQUIRED FOR THIS FEATURE.
5. OPTIONAL ROCK CHECK DAM TO BE LOCATED TO REDUCE VELOCITIES PER DESIGN REPORT.
6. RIPRAP AND ROCK MULCH REQUIRED WHEN VELOCITIES EXCEED TABLE 6.2 OF THE FLOOD CONTROL DISTRICT OF MARICOPA COUNTY HYDRAULICS MANUAL.

DETAIL NO. LID-06	STANDARD DETAIL ENGLISH	VEGETATED OR ROCK BIOSWALES	REVISED 01-29-2019	DETAIL NO. LID-06
----------------------	----------------------------	-----------------------------	-----------------------	----------------------

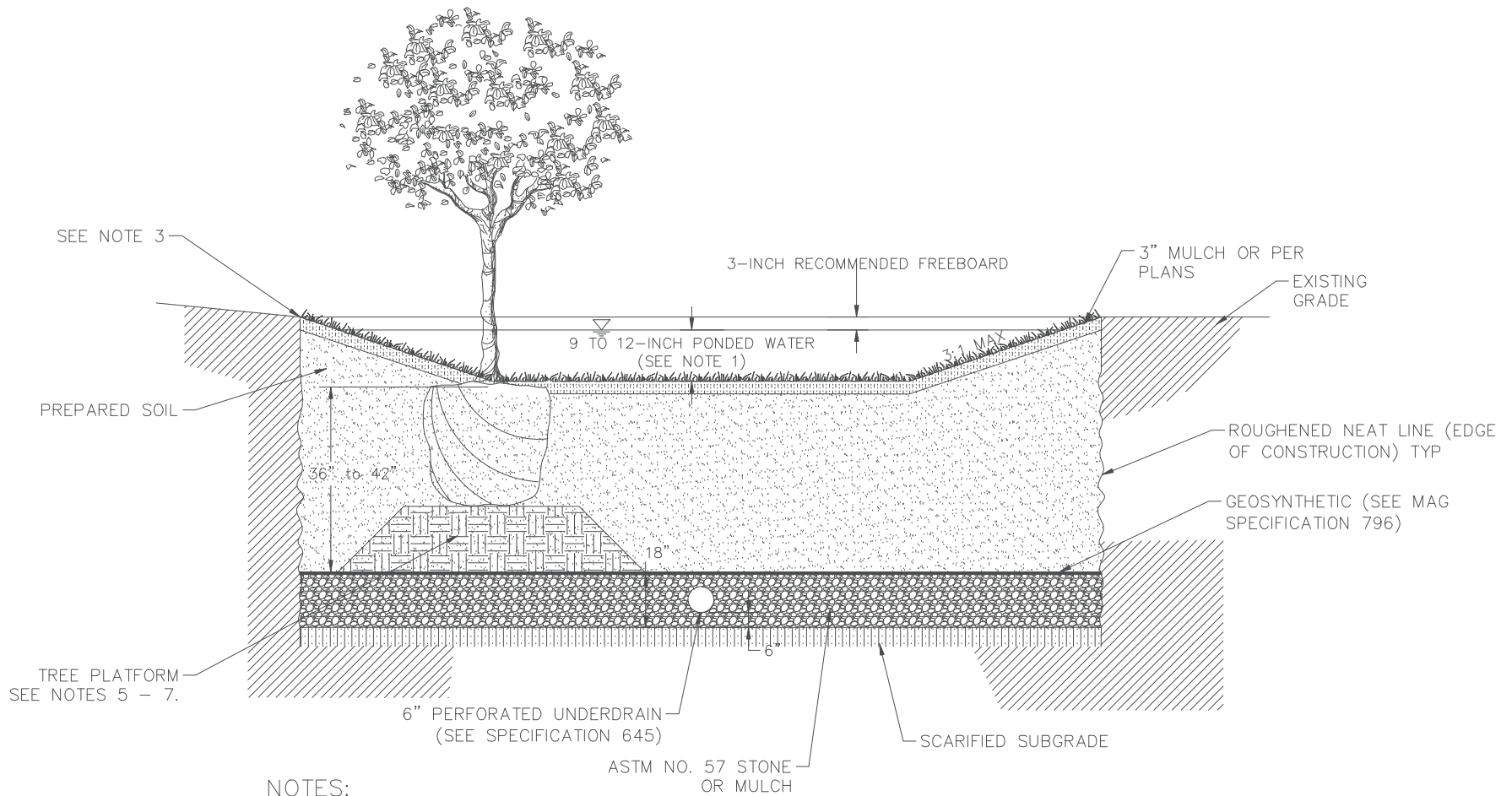

**NOTES:**

1. SURFACE PONDING WATER MUST PERCOLATE WITHIN 36-HOURS.
2. MINIMUM DEPTH OF 36 TO 42 INCHES TO ACCOMMODATE 48-INCH BOX TREE PLANTING.
3. SEE SPECIFICATION 645 FOR BUILDING SETBACK DISTANCES.
4. INTENDED TO CAPTURE SUBWATERSHED, DEDICATED OUTLET STILL REQUIRED.
5. TREE PLATFORM SHALL CONSIST OF COMPACTED ON-SITE SOIL. PLATFORM SHALL BE 1.5X THE WIDTH OF THE ROOTBALL AND INCLUDE 45-DEGREE SIDE SLOPES (MAX.).
6. INSTALL FILTER FABRIC BETWEEN TREE PLATFORM AND NO.57 STONE/ROCK MULCH.
7. TREE PLATFORMS TO BE PLACED TREE LOCATIONS. REFER TO LANDSCAPE PLAN.

**NOTES:**

1. **DETAIL IS PROHIBITED FOR USE ALONG ARTERIAL CLASSIFIED ROADWAYS.**
2. **UTILIZATION WITHIN THE PUBLIC RIGHT OF WAY REQUIRES A PRIVATE MAINTENANCE AGREEMENT WITH THE CITY OF PHOENIX.**

DETAIL NO.  
LID-07

STANDARD DETAIL  
ENGLISH

BIORETENTION SYSTEMS

REVISED  
01-29-2019

DETAIL NO.  
LID-07

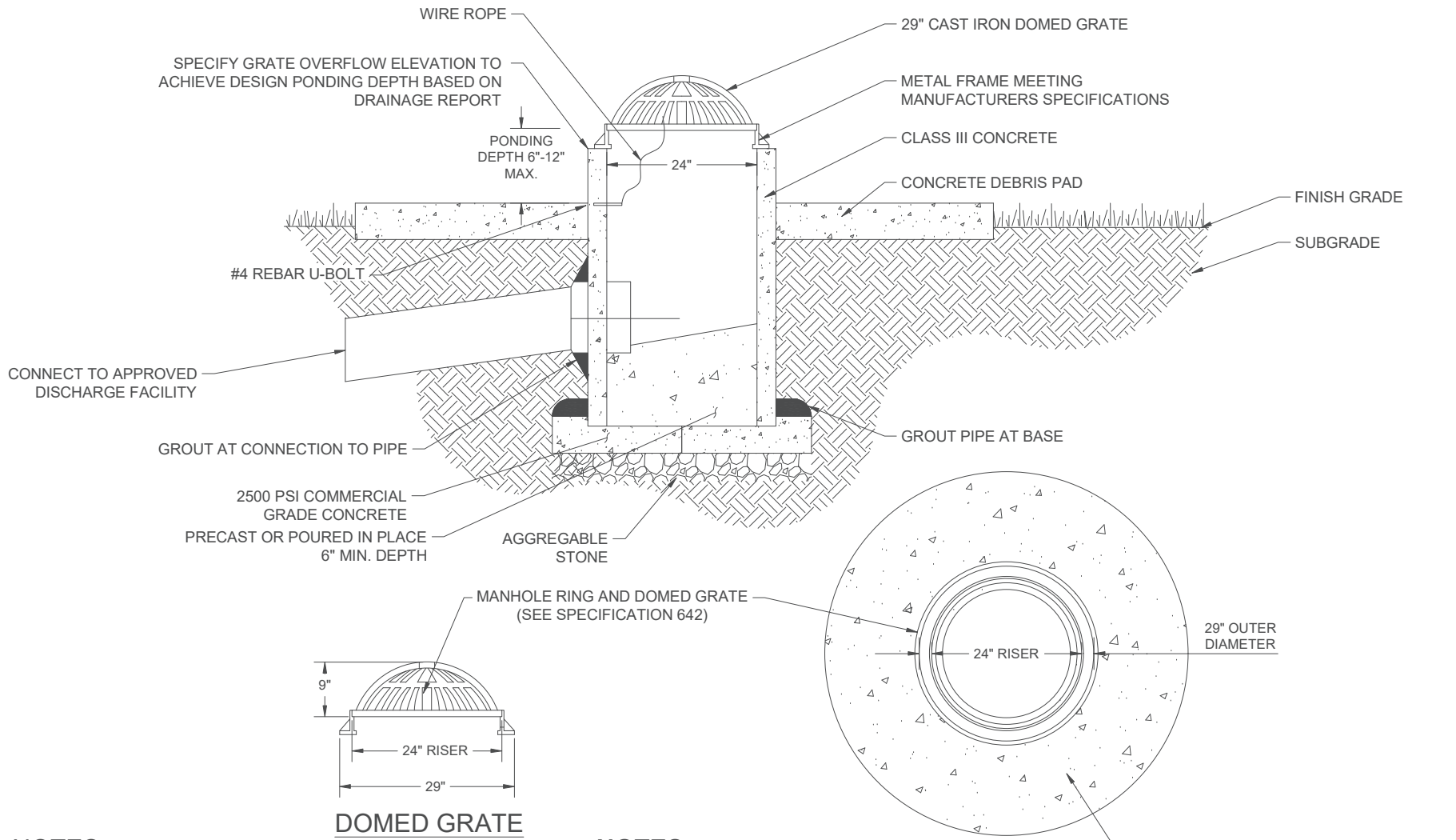

**NOTES:**

1. PROVIDE GRATE OVERFLOW ELEVATION ON PLAN.
2. DO NOT ADJUST OVERFLOW GRATE ELEVATION, CONSTRUCT AS SHOWN ON PLANS.
3. GRATE OVERFLOW ELEVATION SHALL BE 3-INCHES BELOW ADJACENT SIDEWALK OR CURB.
4. LOCATE ON DOWNSTREAM END OF FACILITY.
5. VEGETATION PLACED 2- FEET AWAY FROM DEBRIS PAD.

**NOTES:**

1. **DETAIL IS PROHIBITED FOR USE ALONG ARTERIAL CLASSIFIED ROADWAYS.**
2. **UTILIZATION WITHIN THE PUBLIC RIGHT OF WAY REQUIRES A PRIVATE MAINTENANCE AGREEMENT WITH THE CITY OF PHOENIX.**

**REVERSIBLE MANHOLE FRAME**

DETAIL NO. LID-10	STANDARD DETAIL ENGLISH	DOMED OVERFLOW STRUCTURES	REVISED 01-29-2019	DETAIL NO. LID-10
----------------------	----------------------------	------------------------------	-----------------------	----------------------